

# Wiper motor circuit

## CIRCUIT DESCRIPTION

Wiper motor is controlled by the Body ECU. Even CPU is in the failure, its circuit structure enables to operate the wiper with "High" mode.

## WIRING DIAGRAM

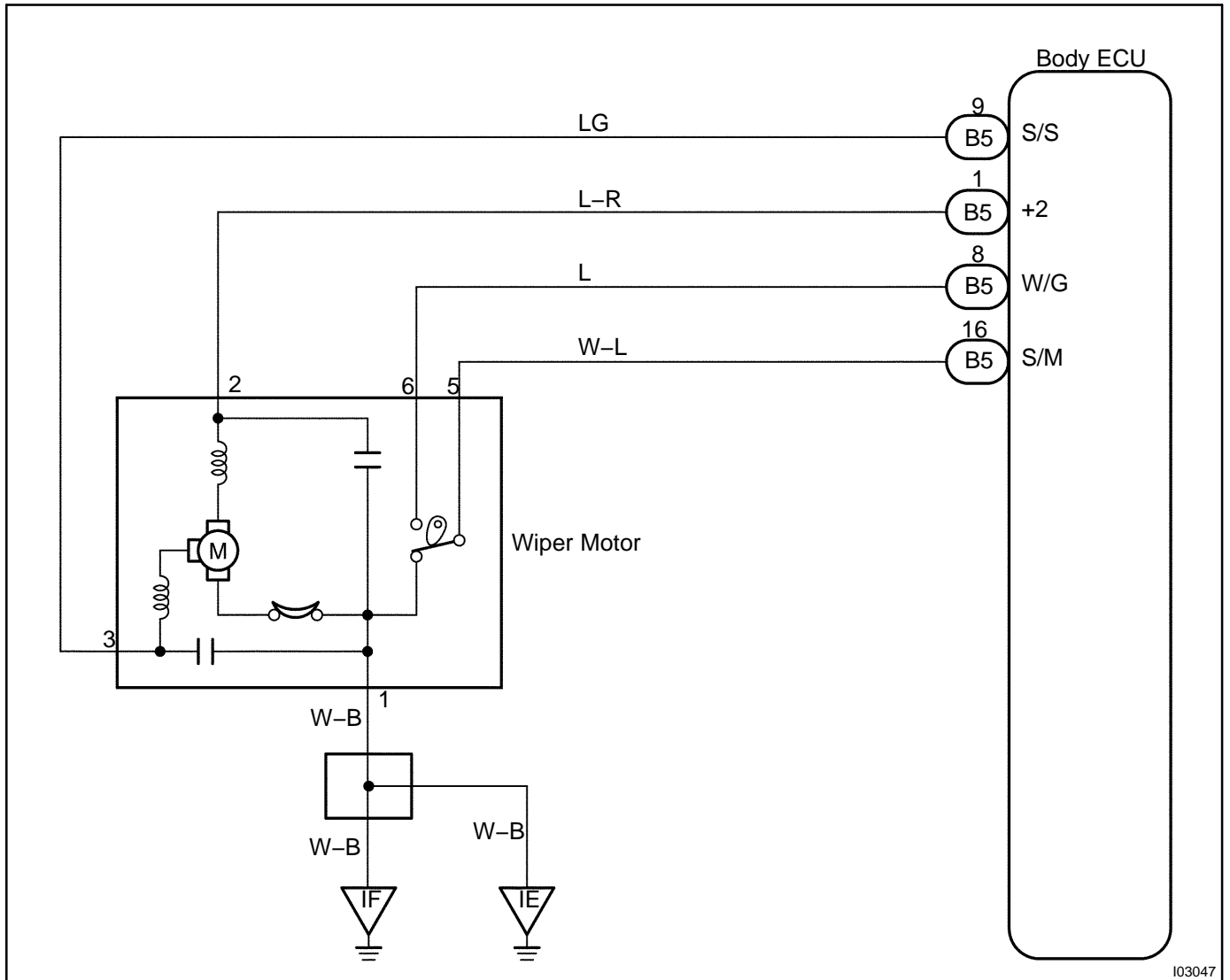

103047

## INSPECTION PROCEDURE

### HINT:

In case of using the LEXUS hand-held tester, start the inspection from step 1 and in case of not using the LEXUS hand-held tester, start from step 2.

<b>1</b>	<b>Check wiper motor using LEXUS hand-held tester.</b>
----------	--

### PREPARATION:

Connect the LEXUS hand-held tester to the DLC 3.

### CHECK:

Check that the wiper motor can operate in an ACTIVE TEST.

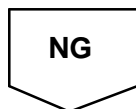
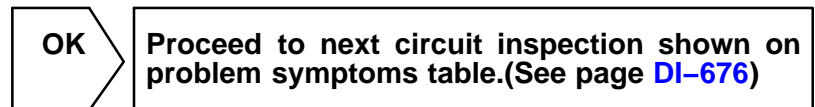

<b>2</b>	<b>Check wiper motor. (See page <a href="#">BE-83</a>)</b>
----------	--

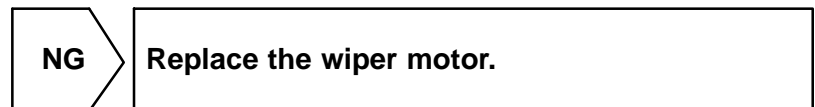

<b>3</b>	<b>Check wireharness and connector between wiper motor and Body ECU.</b>
----------	--

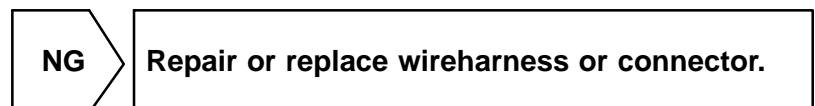

<b>Proceed to next circuit inspection shown on problem symptoms table. (See page <a href="#">DI-676</a>)</b>
--