

COOLANT INSPECTION

CO07C-03

1. CHECK ENGINE COOLANT LEVEL AT RADIATOR RESERVOIR

The engine coolant level should be between the "LOW" and "FULL" lines at normal temperature (20°C (68°F)).

If low, check for leaks and add "Toyota Long Life Coolant" or equivalent up to the "FULL" line.

2. CHECK ENGINE COOLANT QUALITY

(a) Remove the radiator cap from the reservoir.

CAUTION:

To avoid the danger of being burned, do not remove the radiator cap while the engine and radiator are still hot, as fluid and steam can be blown out under pressure.

(b) There should not be any excessive deposits of rust or scale around the radiator cap or reservoir filler hole, and the coolant should be free from oil.

If excessively dirty, clean the coolant passages and replace the coolant.

(c) Reinstall the radiator cap.

REPLACEMENT

1. REMOVE V-BANK COVER

2. DRAIN ENGINE COOLANT

- (a) Remove the radiator cap from the radiator reservoir.

CAUTION:

To avoid the danger of being burned, do not remove the radiator cap while the engine and radiator are still hot, as fluid and steam can be blown out under pressure.

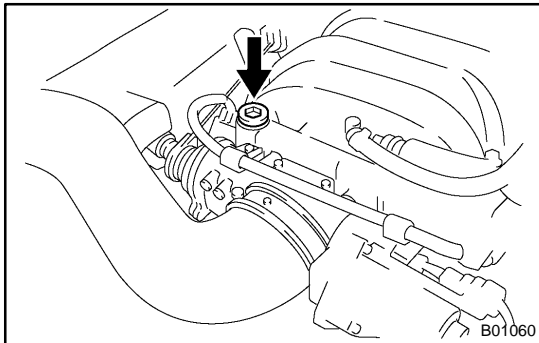

- (b) Remove the water filler plug from the throttle body.

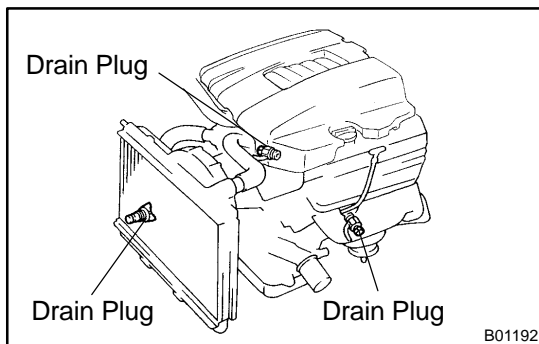

- (c) Remove the 3 drain plugs on the engine and radiator, and drain the coolant.

- (d) Close the 3 drain plugs.

Torque: 12.7 N·m (130 kgf·cm, 9 ft·lbf) for engine drain plug

3. REFILL WITH ENGINE COOLANT

- (a) Slowly fill coolant to the throttle body until it is full.

- ◆ Use of improper coolants may damage engine cooling system.
- ◆ Use "Toyota Long Life Coolant" or equivalent and mix it with plain water according to the manufacturer's directions.
- ◆ Use of the coolant which includes more than 50% (freezing protection down to -35°C (-31°F)) or 60% (freezing protection down to -50°C (-58°F)) of ethylene-glycol is recommended, but not more than 70%.

NOTICE:

- ◆ Do not use an alcohol type coolant or plain water alone.
- ◆ The coolant should be mixed with plain water (preferably demineralized water or distilled water).

Capacity (w/ Heater):

11.0 liters (11.6 US qts, 9.7 Imp. qts)

- (b) Install the water filler plug to the throttle body.

Torque: 45 N·m (459 kgf·cm, 33 ft·lbf)

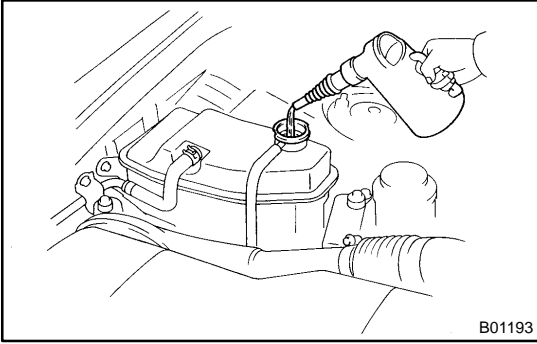

- (c) Slowly pour coolant into the radiator reservoir until it is "FULL".
 - (d) Install the radiator cap.
 - (e) Bleed the cooling system.
 - ◆ Start the engine, and open the heater water valve.
 - ◆ Maintain the engine speed at 2,000 – 2,500 rpm, and warm up the engine.
 - (f) Stop the engine, and wait until the engine coolant cools down.
 - (g) Refill coolant into the reservoir until it is "FULL".
- 4. CHECK ENGINE COOLANT FOR LEAKS**
 - 5. CHECK ENGINE COOLANT SPECIFIC GRAVITY CORRECTLY**
 - 6. REINSTALL V-BANK COVER**

WATER PUMP COMPONENTS

CO07E-02

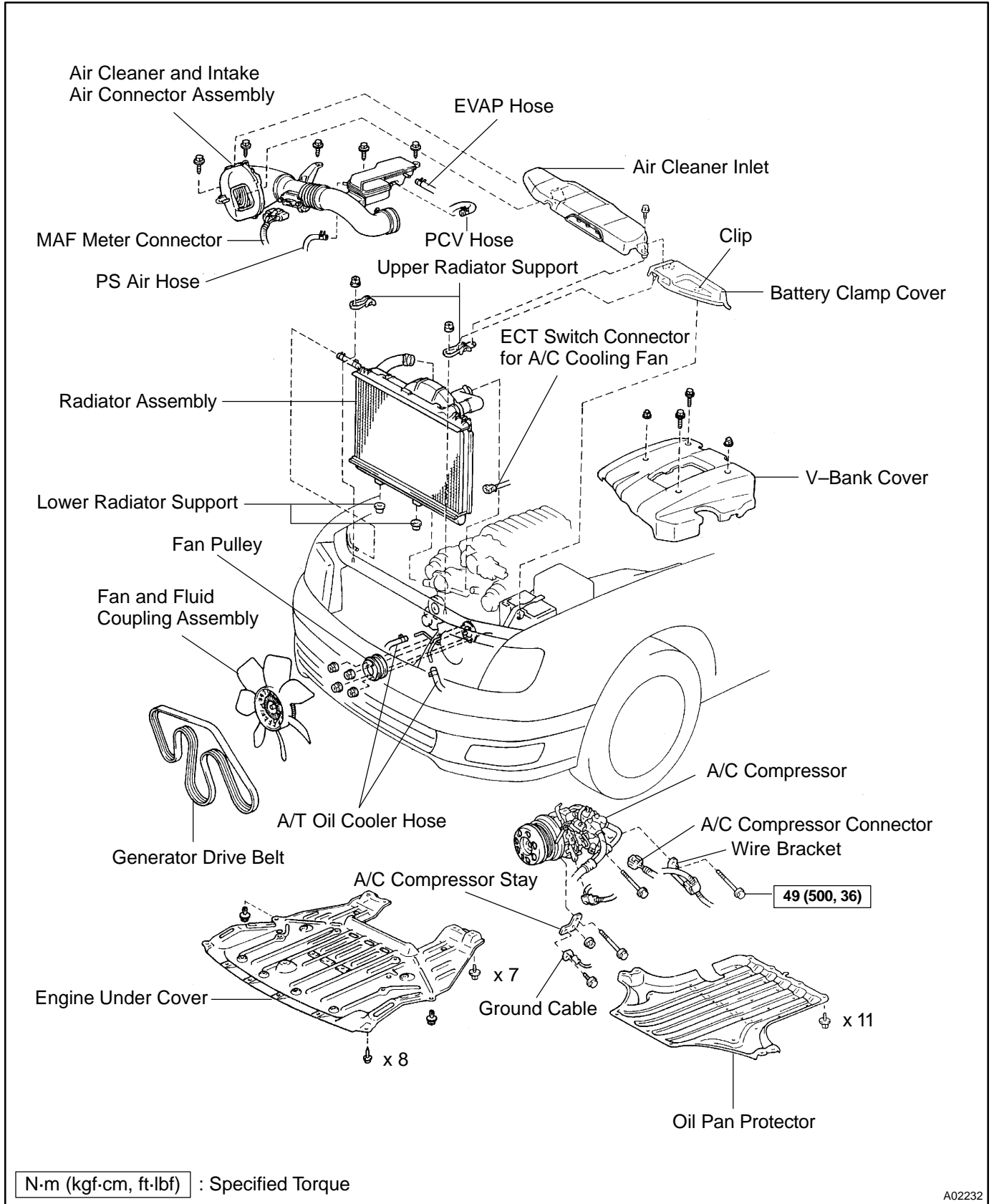

A02232

COOLING - WATER PUMP

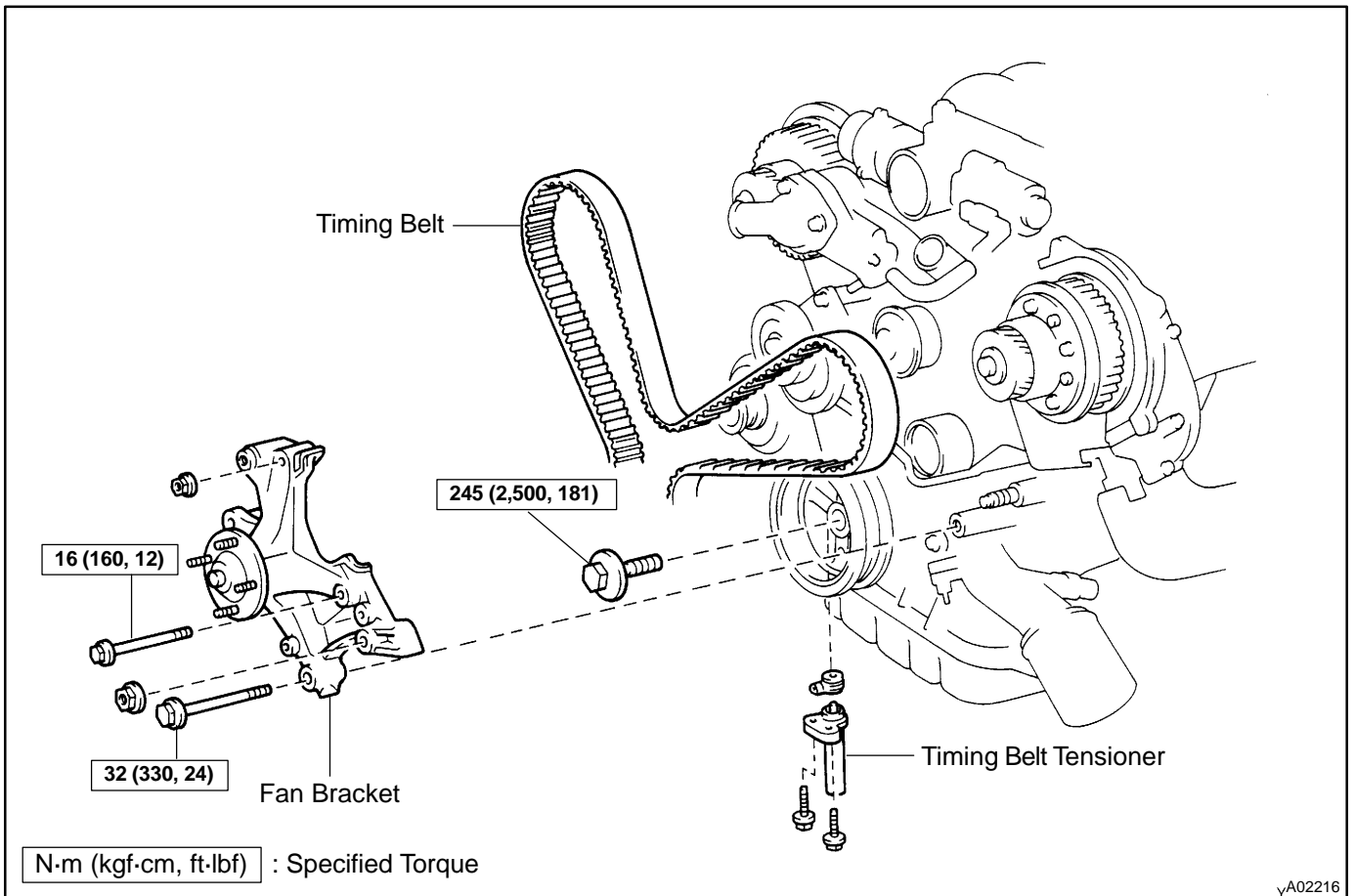
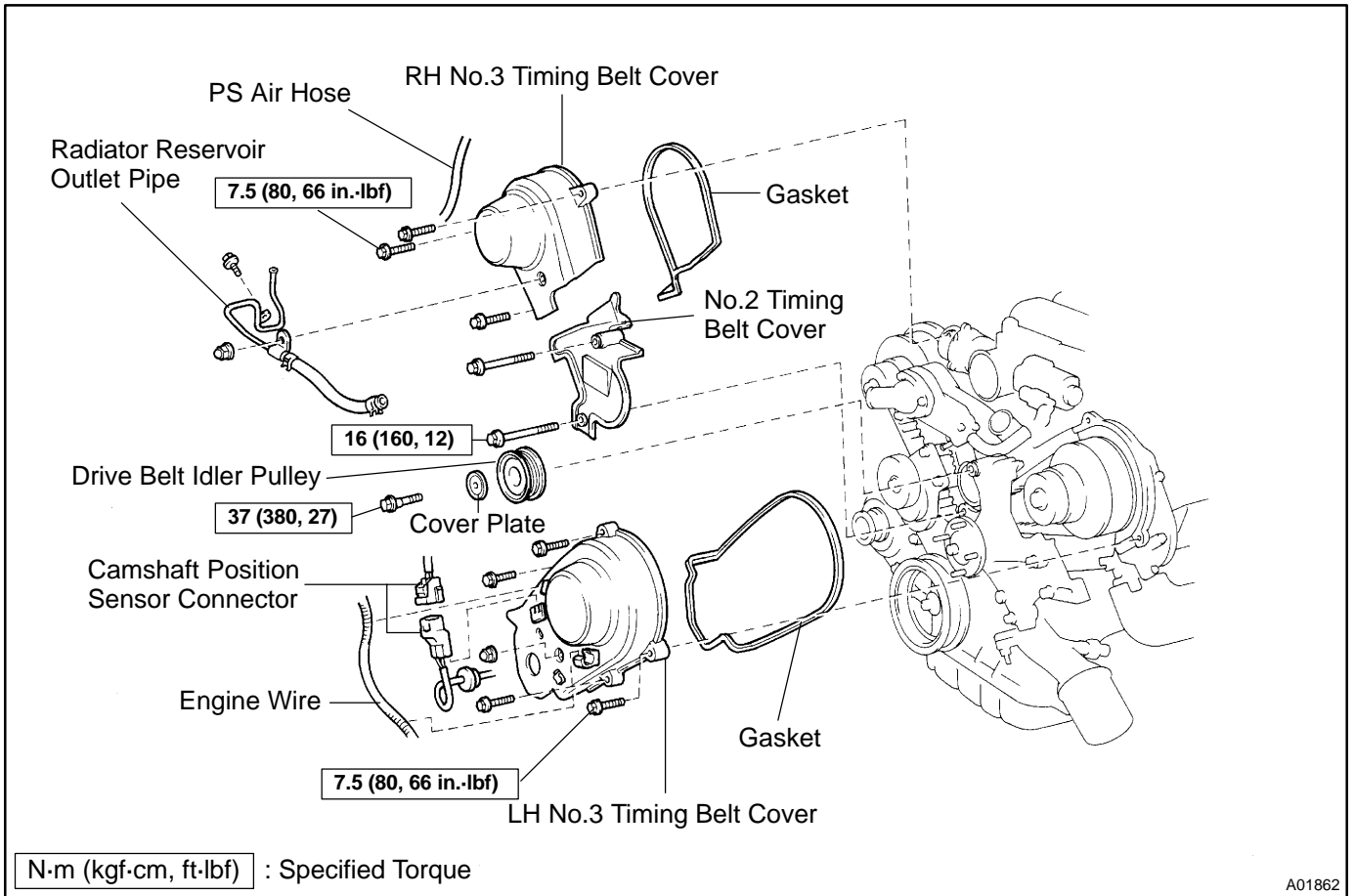

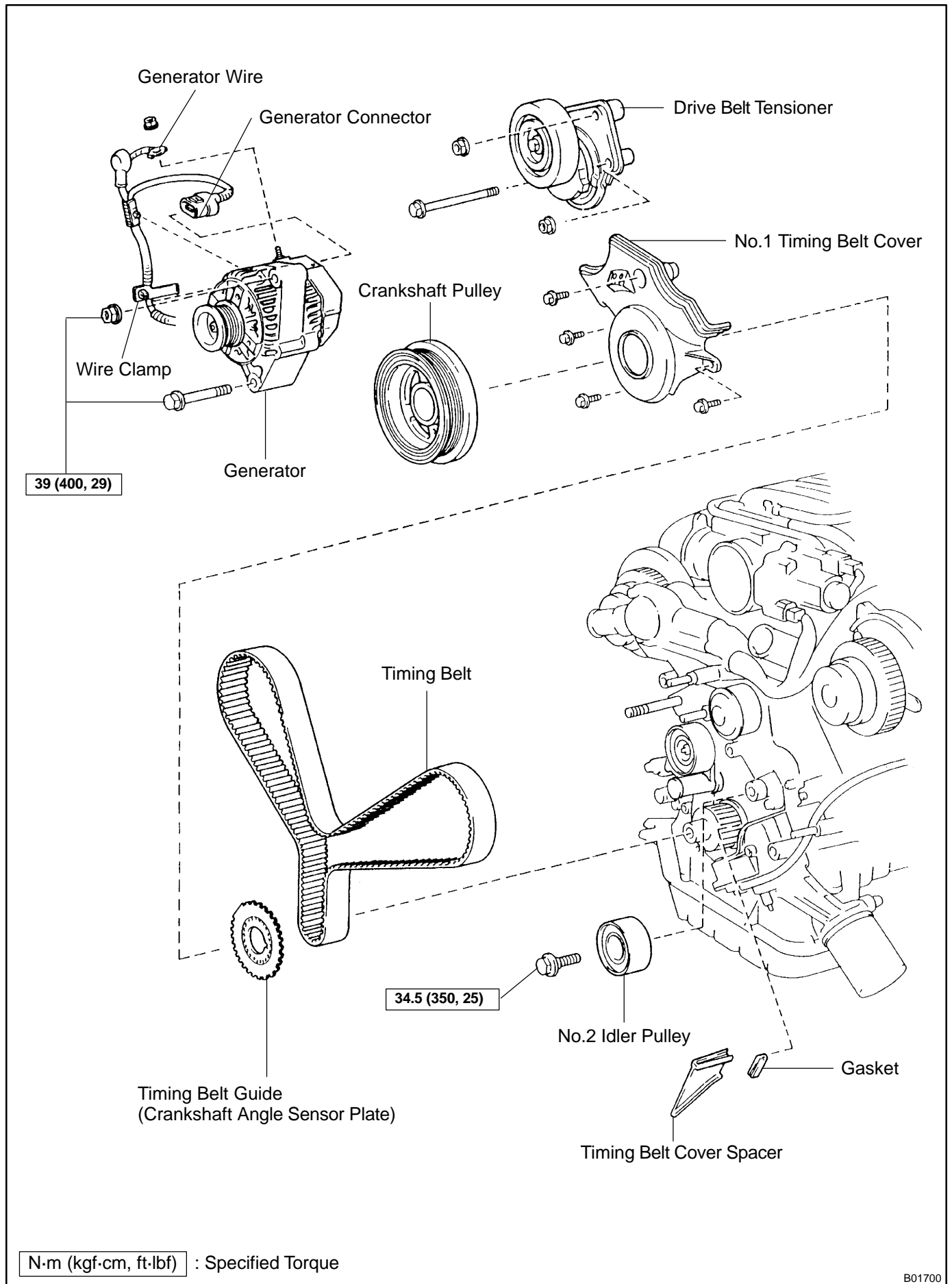

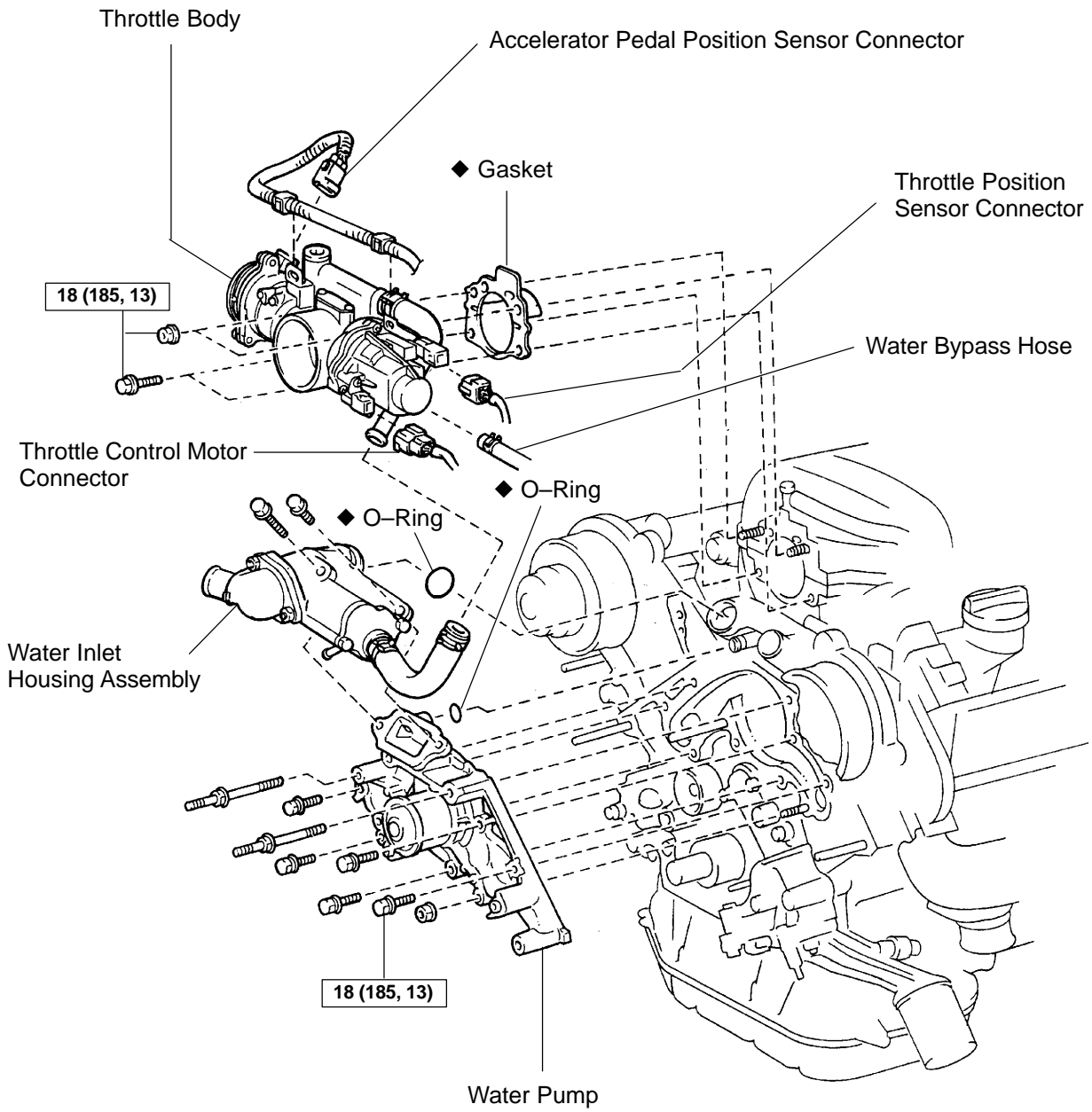

N·m (kgf·cm, ft·lbf) : Specified Torque

◆ Non-reusable part

B01040

REMOVAL

1. REMOVE TIMING BELT (See page [EM-15](#))
2. REMOVE NO.2 IDLER PULLEY (See page [EM-15](#))
3. REMOVE THROTTLE BODY (See page [SF-42](#))

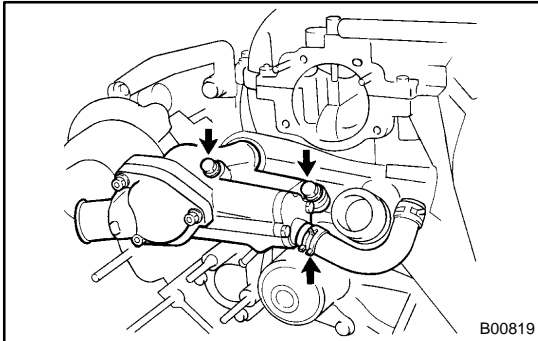

4. REMOVE WATER INLET AND INLET HOUSING ASSEMBLY

- (a) Remove the 2 bolts and water inlet and inlet housing assembly.
- (b) Remove the water bypass hose (from the throttle body) from the water inlet housing.
- (c) Remove the O-ring from the water inlet housing.

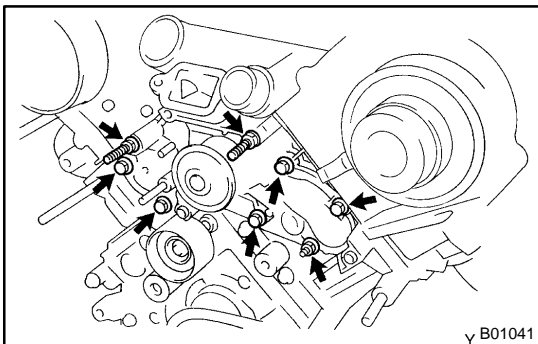

5. REMOVE WATER PUMP

- (a) Remove the 5 bolts, 2 stud bolts and nut.

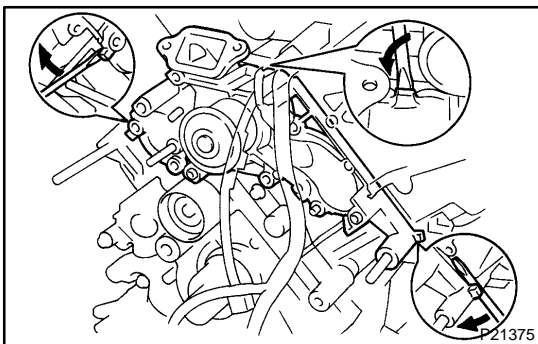

- (b) Using a screwdriver, remove the water pump by prying the portions between the water pump and cylinder block.
- (c) Remove the O-ring from the water bypass pipe.

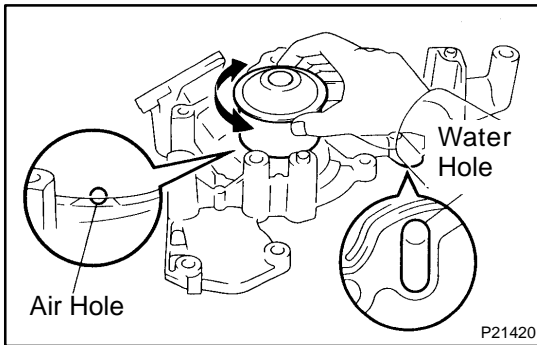

INSPECTION

1. INSPECT WATER PUMP

- (a) Visually check the air hole and water hole for coolant leakage.

If leakage is found, replace the water pump and timing belt.

- (b) Turn the pulley, and check that the water pump bearing moves smoothly and quietly.

If necessary, replace the water pump.

2. INSPECT TIMING BELT COMPONENTS

(See page [EM-20](#))

INSTALLATION

1. INSTALL WATER PUMP

- (a) Remove any old packing (FIPG) material and be careful not to drop any oil on the contact surfaces of the water pump and cylinder block.
 - ◆ Using a razor blade and gasket scraper, remove all the old packing (FIPG) material from the gasket surfaces and sealing groove.
 - ◆ Thoroughly clean all components to remove all the loose material.
 - ◆ Using a non-residue solvent, clean both sealing surfaces.

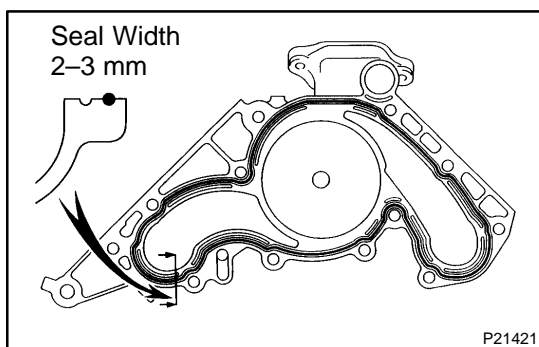

- (b) Apply seal packing to the water pump as shown in the illustration.

Seal packing:

Part No. 08826-00100 or equivalent

- ◆ Install a nozzle that has been cut to a 2 – 3 mm (0.08 – 0.12 in.) opening.
- ◆ Parts must be assembled within 5 minutes of application. Otherwise the material must be removed and reapplied.
- ◆ Immediately remove nozzle from the tube and reinstall cap.

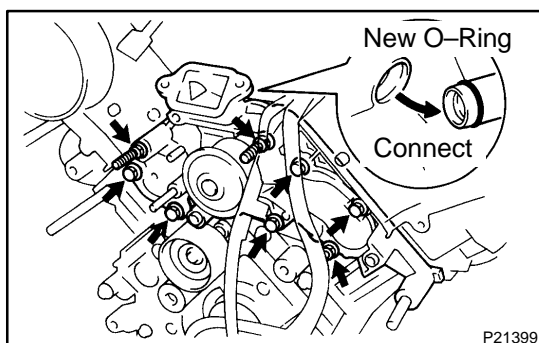

- (c) Install a new O-ring to the water bypass pipe end.
- (d) Apply soapy water to the O-ring.
- (e) Connect the water pump to the water bypass pipe end.
- (f) Install the water pump with the 5 bolts, 2 stud bolts and nut. Uniformly tighten the bolts, stud bolts and nut in several passes.

Torque: 18 N·m (185 kgf·cm, 13 ft·lbf)

HINT:

Use bolts 30 mm (1.18 in.) in length.

2. INSTALL WATER INLET AND INLET HOUSING ASSEMBLY

- (a) Remove any old packing (FIPG) material and be careful not to drop any oil on the contact surfaces of the water inlet housing and water pump.
- ◆ Using a razor blade and gasket scraper, remove all the old packing (FIPG) material from the gasket surfaces and sealing groove.
 - ◆ Thoroughly clean all components to remove all the loose material.
 - ◆ Using a non-residue solvent, clean both sealing surfaces.

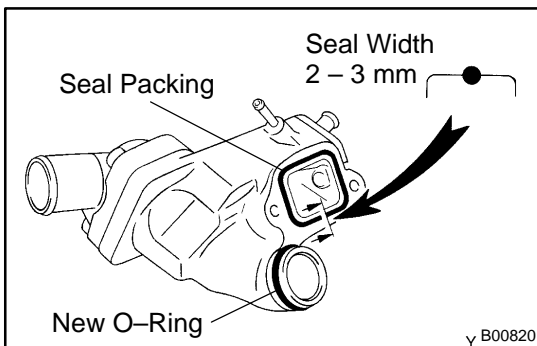

- (b) Apply seal packing to the sealing groove of water inlet housing as shown in the illustration.

Seal packing:

Part No. 08826-00100 or equivalent

- ◆ Install a nozzle that has been cut to a 2 – 3 mm (0.08 – 0.12 in.) opening.
 - ◆ Parts must be assembled within 5 minutes of application. Otherwise the material must be removed and reapplied.
 - ◆ Immediately remove nozzle from the tube and reinstall cap.
- (c) Install a new O-ring to the water inlet housing.
- (d) Apply soapy water on the O-ring.
- (e) Push the water inlet housing end into the water pump hole.
- (f) Connect the water bypass hose (from the throttle body) to the water inlet housing.

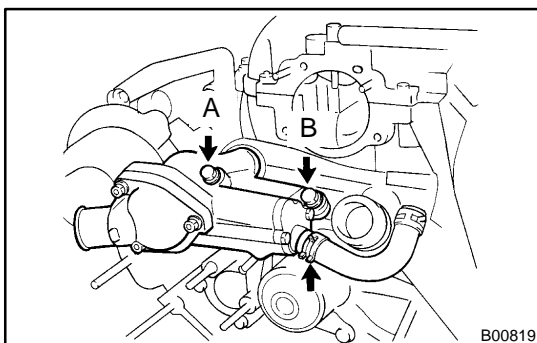

- (g) Install the water inlet and housing assembly with the 2 bolts. Alternately tighten the bolts.

Torque: 18 N·m (185 kgf·cm, 13 ft·lbf)

HINT:

Each bolt length is indicated in the illustration.

Bolt length:

75 mm (2.95 in.) for A

25 mm (0.98 in.) for B

3. INSTALL THROTTLE BODY (See page SF-42)

4. INSTALL NO.2 IDLER PULLEY (See page EM-22)

5. **INSTALL TIMING BELT (See page [EM-22](#))**
6. **RECHECK ENGINE COOLANT LEVEL**

THERMOSTAT COMPONENTS

CO071-03

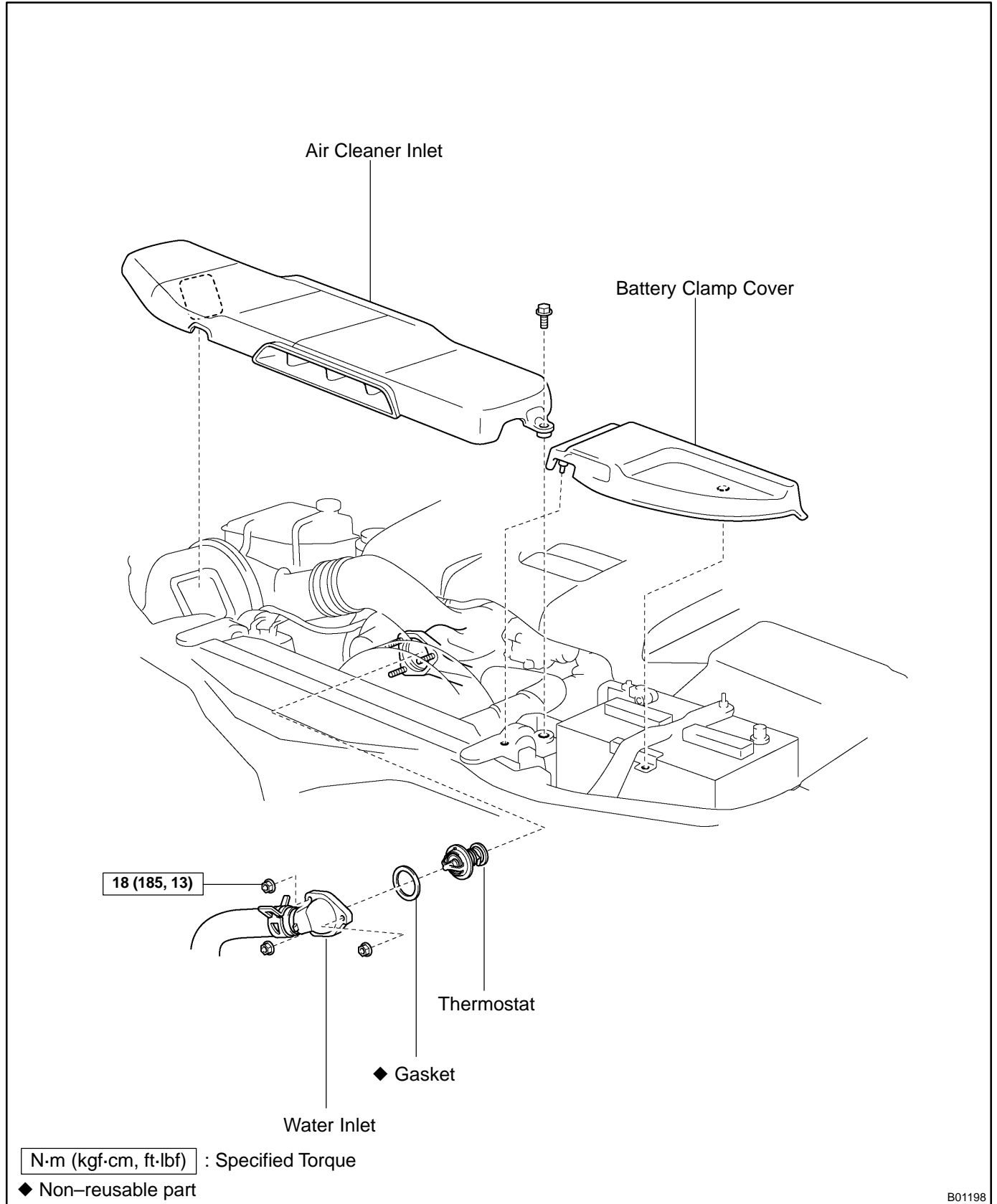

B01198

REMOVAL

HINT:

Removal of the thermostat would have an adverse effect, causing a lowering of cooling efficiency. Do not remove the thermostat, even if the engine tends to overheat.

1. **DRAIN ENGINE COOLANT**
2. **REMOVE BATTERY CLAMP COVER AND AIR CLEANER INLET**

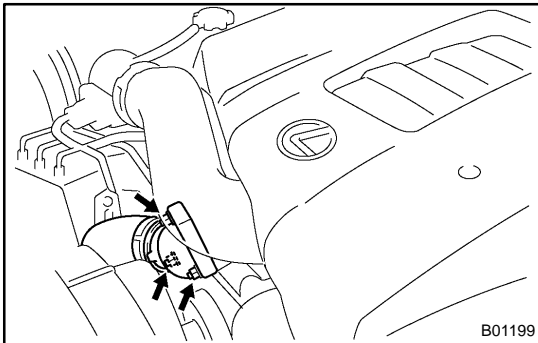

3. **DISCONNECT WATER INLET FROM WATER INLET HOUSING**

Remove the 3 nuts holding the water inlet to the inlet housing, and disconnect the water inlet together with the radiator hose from the water inlet housing.

4. **REMOVE THERMOSTAT FROM WATER INLET HOUSING**

- (a) Remove the thermostat.
- (b) Remove the gasket from the thermostat.

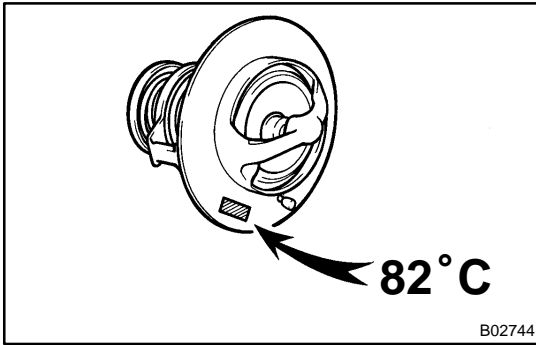

INSPECTION

INSPECT THERMOSTAT

HINT:

The thermostat is numbered with the valve opening temperature.

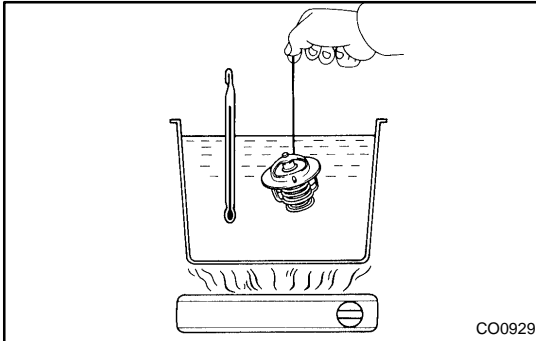

(a) Immerse the thermostat in water and gradually heat the water.

(b) Check the valve opening temperature.

Valve opening temperature: 80 – 84 °C (176 – 183 °F)

If the valve opening temperature is not as specified, replace the thermostat.

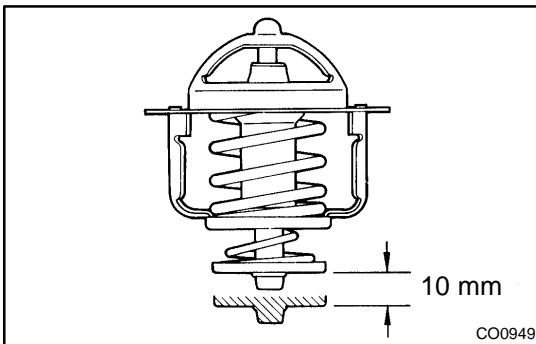

(c) Check the valve lift.

Valve lift: 10 mm (0.39 in.) or more at 95 °C (203 °F)

If the valve lift is not as specified, replace the thermostat.

(d) Check that the valve is fully closed when the thermostat is at low temperatures (below 40 °C (104 °F)).

If not closed, replace the thermostat.

INSTALLATION

1. PLACE THERMOSTAT IN WATER INLET HOUSING

- (a) Install a new gasket to the thermostat.

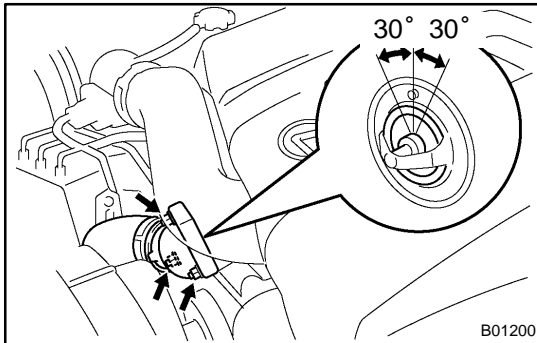

- (b) Insert the thermostat into the water inlet housing with the jiggle valve facing straight upward.

HINT:

The jiggle valve may be set within 30° of either side of the prescribed position.

2. INSTALL WATER INLET

Torque: 18 N·m (185 kgf·cm, 13 ft·lbf)

3. FILL WITH ENGINE COOLANT

4. START ENGINE AND CHECK FOR COOLANT LEAKS

5. RECHECK ENGINE COOLANT LEVEL

6. INSTALL AIR CLEANER INLET AND BATTERY CLAMP COVER

RADIATOR

ON-VEHICLE CLEANING

CO07M-01

Using water or a steam cleaner, remove any mud and dirt from the radiator core.

NOTICE:

If using a high pressure type cleaner, be careful not to deform the fins of the radiator core. (i.e. Maintain a distance between the cleaner nozzle and radiator core.)

ON-VEHICLE INSPECTION

1. REMOVE RADIATOR CAP FROM RESERVOIR TANK

CAUTION:

To avoid the danger of being burned, do not remove the radiator cap while the engine and radiator are still hot, as fluid and steam can be blown out under pressure.

2. INSPECT RADIATOR CAP

NOTICE:

- ◆ If the radiator cap has contaminations, always rinse it with water.
- ◆ Before using a radiator cap tester, wet the relief valve and pressure valve with engine coolant or water.

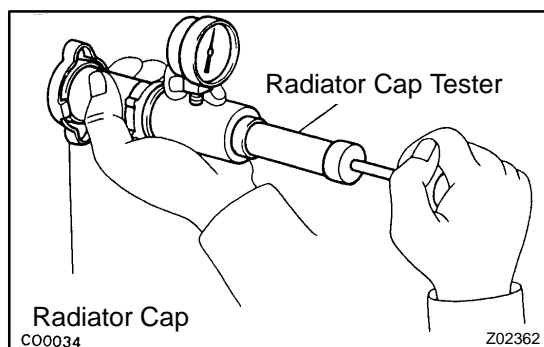

Using a radiator cap tester, pump the tester and measure the relief valve opening pressure.

Opening pressure:

Standard	74 – 103 kPa (0.75 – 1.05 kgf/cm ² , 10.7 – 14.9 psi)
Minimum	59 kPa (0.6 kgf/cm ² , 8.5 psi)

HINT:

Use the tester's maximum reading as the opening pressure. If the opening pressure is less than minimum, replace the radiator cap.

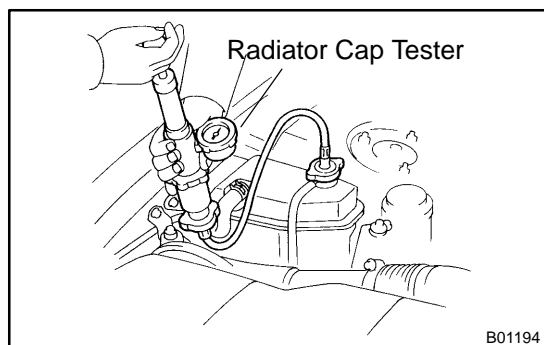

3. INSPECT COOLING SYSTEM FOR LEAKS

- (a) Fill the radiator with coolant and attach a radiator cap tester to the water filler.
- (b) Warm up the engine.
- (c) Pump it to 118 kPa (1.2 kgf/cm², 17.1 psi), and check that the pressure does not drop.

If the pressure drops, check the hoses, radiator or water pump for leaks. If no external leaks are found, check the heater core, cylinder block and cylinder head.

4. REINSTALL RADIATOR CAP

COMPONENTS

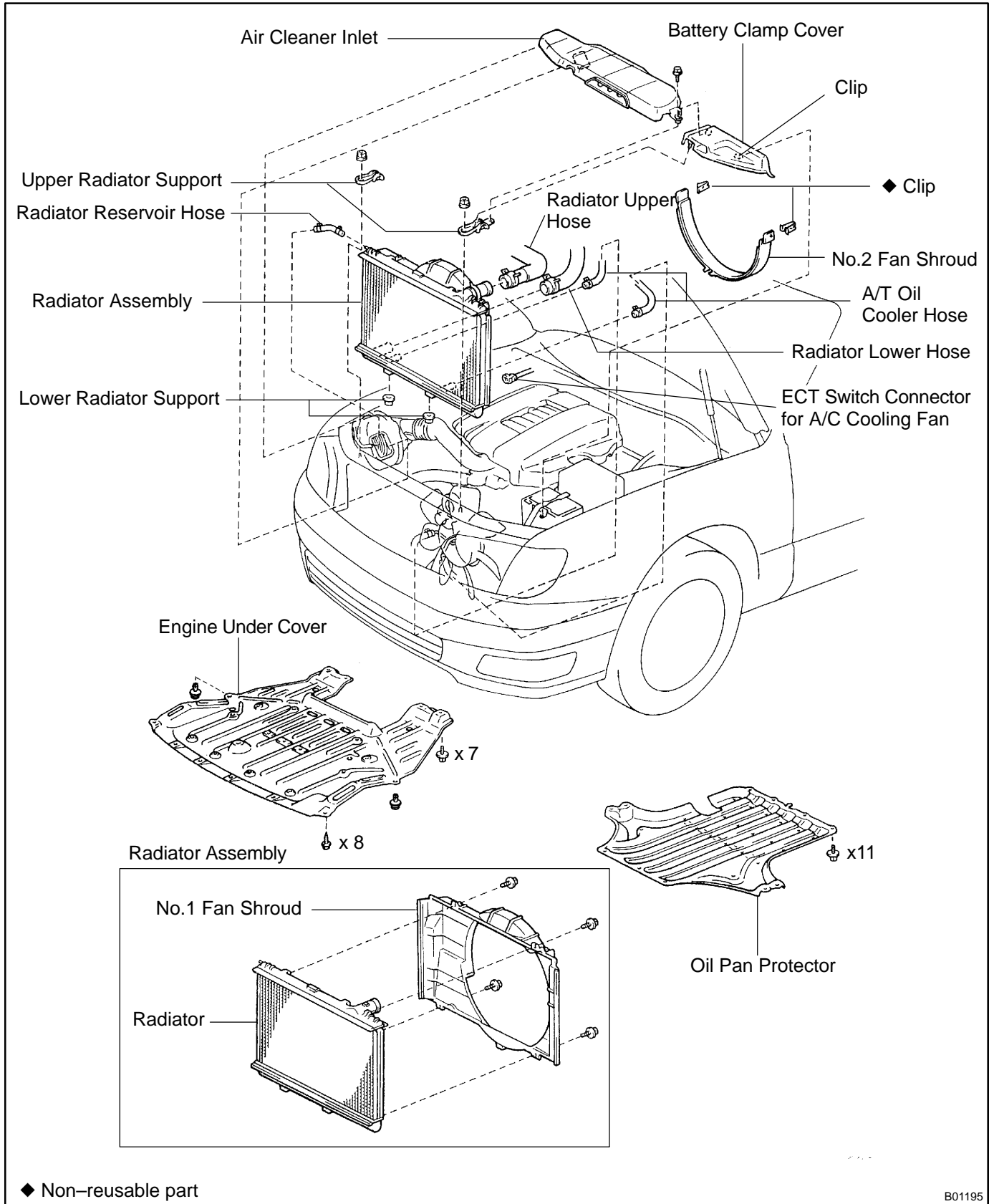

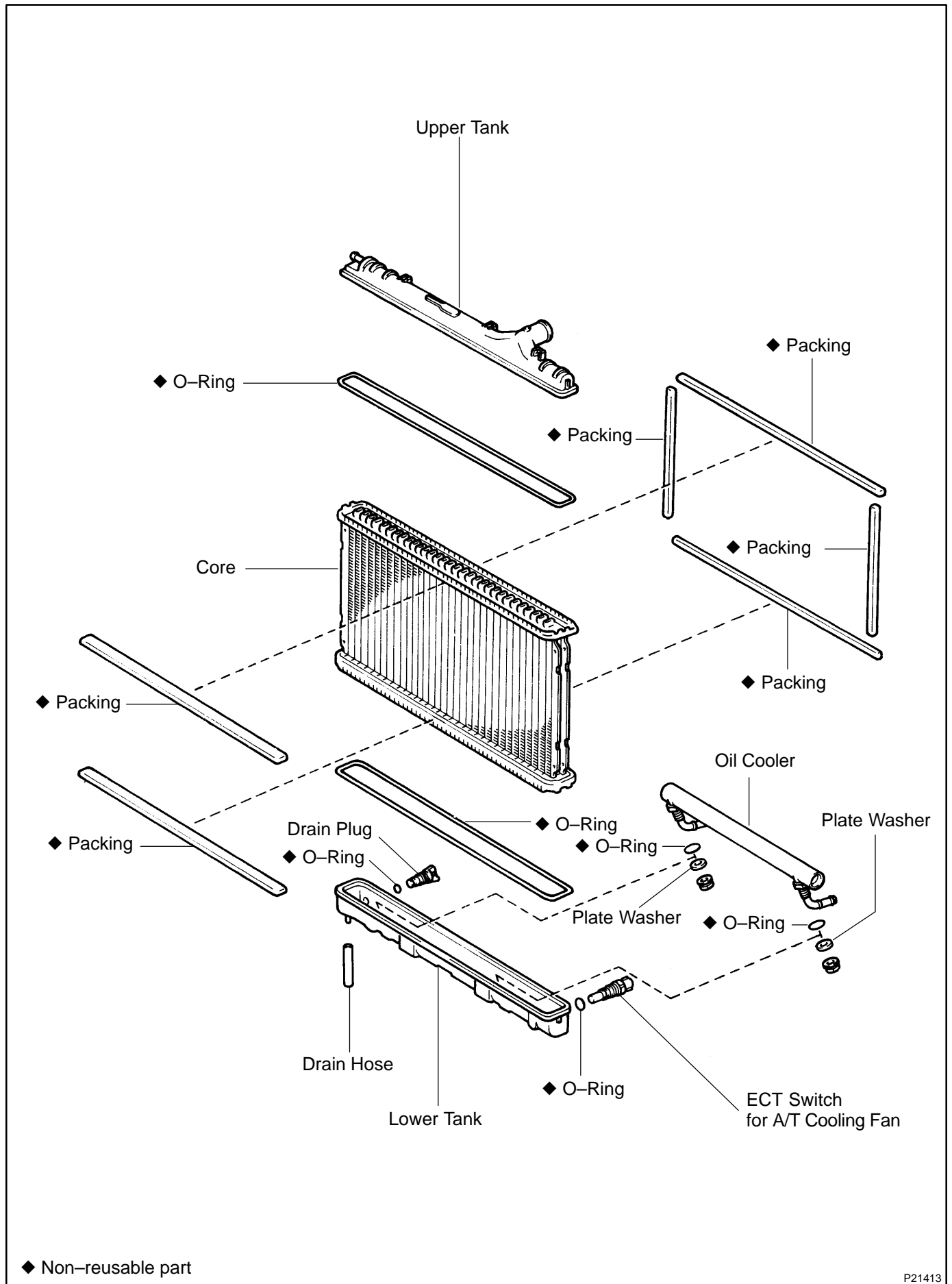

REMOVAL

1. REMOVE OIL PAN PROTECTOR
2. REMOVE ENGINE UNDER COVER
3. DRAIN ENGINE COOLANT
4. REMOVE BATTERY CLAMP COVER
5. REMOVE AIR CLEANER INLET
6. REMOVE RADIATOR RESERVOIR HOSE
7. DISCONNECT UPPER RADIATOR HOSE FROM RADIATOR
8. DISCONNECT LOWER RADIATOR HOSE FROM RADIATOR
9. DISCONNECT A/T OIL COOLER HOSES FROM RADIATOR

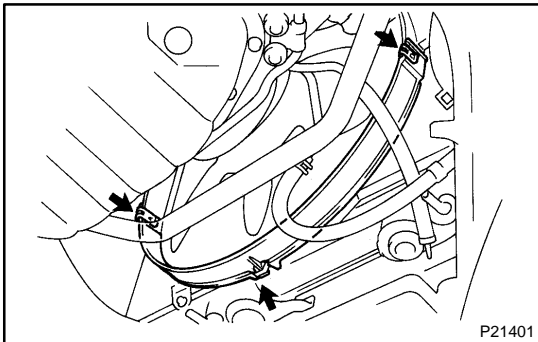
**10. REMOVE NO.2 FAN SHROUD**

- (a) Remove the 2 clips.
- (b) Disconnect the claw of the No.2 fan shroud from the hook of the No.1 fan shroud, and remove the No.2 fan shroud.

11. REMOVE RADIATOR ASSEMBLY

- (a) Disconnect the ECT switch connector for the A/C cooling fan.

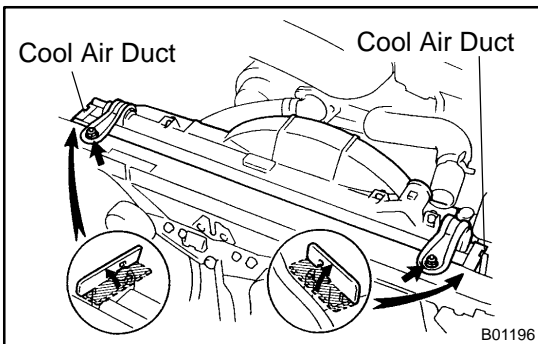

- (b) Disconnect the upper sides of the RH and LH cool air ducts.
- (c) Remove the nut and upper radiator support. Remove the 2 upper radiator supports.
- (d) Lift out the radiator assembly.
- (e) Remove the 2 lower radiator supports from the radiator.

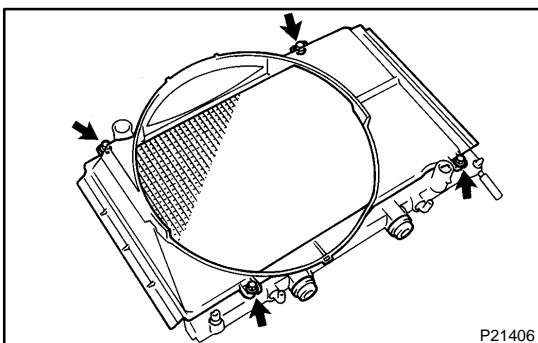
**12. REMOVE NO.1 FAN SHROUD FROM RADIATOR**

Remove the 4 bolts and fan shroud.

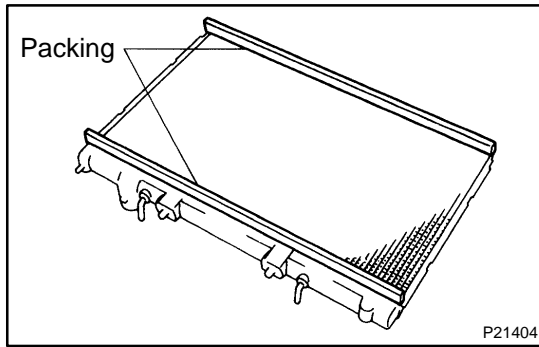

DISASSEMBLY

1. REMOVE PACKINGS

- (a) Remove the 2 packings from the radiator front side.

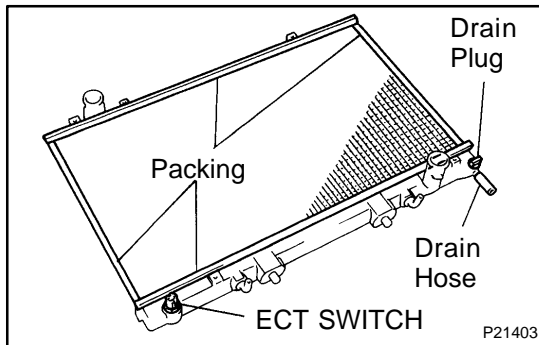

- (b) Remove the 4 packings from the radiator rear side.

2. REMOVE ECT SWITCH FOR A/C COOLING FAN

- (a) Remove the ECT switch.
- (b) Remove the O-ring from the ECT switch.

3. REMOVE DRAIN PLUG

- (a) Remove the drain hose.
- (b) Remove the drain plug.
- (c) Remove the O-ring from the drain plug.

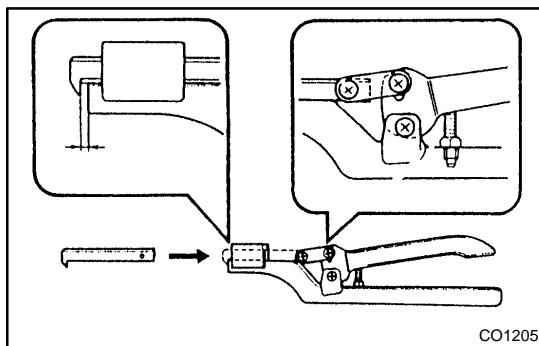

4. ASSEMBLE SST

SST 09230-01010

- (a) Install the claw to the overhaul handle, inserting it in the hole in part "A" as shown in the diagram.
- (b) While gripping the handle, adjust the stopper bolt so that dimension "B" shown in the diagram is 0.2 - 0.3 mm (0.008 - 0.012 in.).

NOTICE:

If this adjustment is not done, the claw may be damaged.

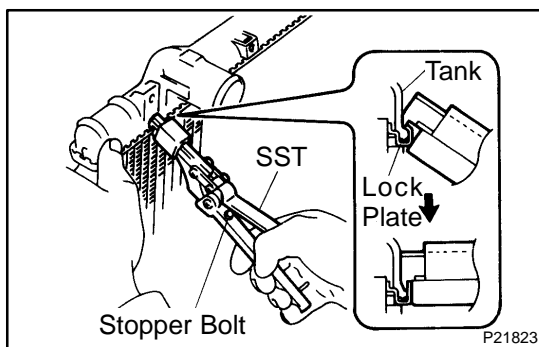

5. UNCAULK LOCK PLATES

Using SST to release the caulking, squeeze the handle until stopped by the stopper bolt.

SST 09230-01010

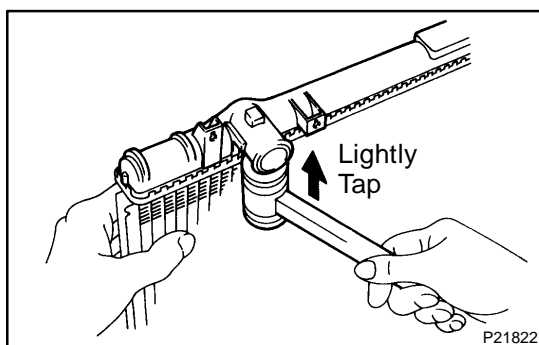

6. REMOVE TANKS AND O-RINGS

- (a) Lightly tap the radiator port (inlet or outlet) with a soft-faced hammer, and remove the tank.
- (b) Remove the O-ring.

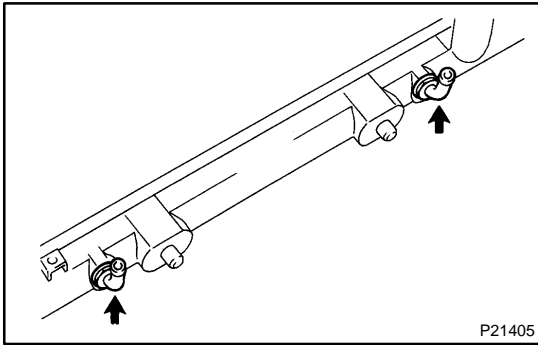
**7. REMOVE OIL COOLER FROM LOWER TANK**

- (a) Remove the 2 nuts and 2 plate washers.
- (b) Remove the oil cooler and 2 O-rings.

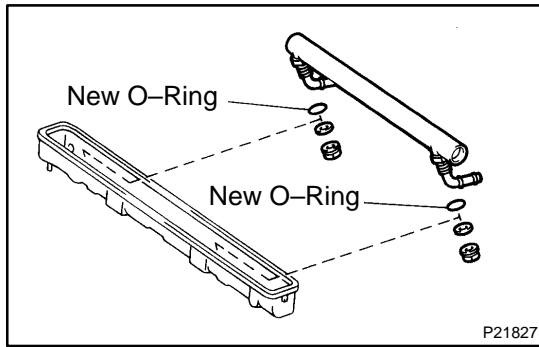

P21827

REASSEMBLY

1. INSTALL OIL COOLER TO LOWER TANK

- (a) Install 2 new O-rings to the oil cooler.
 - (b) Install the oil cooler to the lower tank.
 - (c) Install the 2 plate washers and 2 nuts.
- Torque: 8.34 N·m (85 kgf·cm, 74 in.-lbf)**

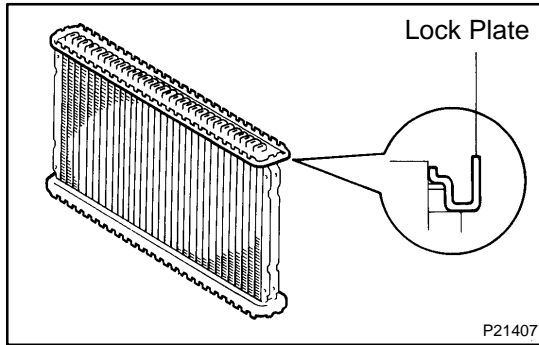

P21407

2. INSPECT LOCK PLATE

Inspect the lock plate for damage.

HINT:

- ◆ If the sides of the lock plate groove are deformed, reassembly of the tank will be impossible.
- ◆ Therefore, first correct any deformation with pliers or similar object. Water leakage will result if the bottom of the lock plate groove is damaged or dented. Therefore, repair or replace if necessary.

NOTICE:

The radiator can only be recalced 2 times.

After the 2nd time, the radiator core must be replaced.

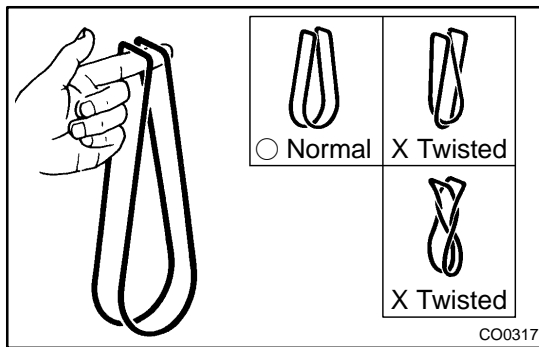

CO0317

3. INSTALL NEW O-RINGS AND TANKS

- (a) After checking that there are no foreign objects in the lock plate groove, install the new O-ring without twisting it.

HINT:

When cleaning the lock plate groove, lightly rub it with sand paper without scratching it.

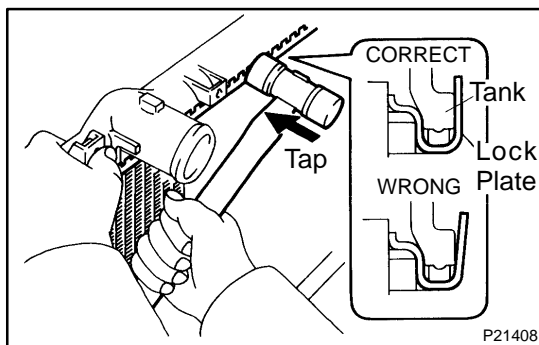

P21408

- (b) Install the tank without damaging the O-ring.
- (c) Tap the lock plate with a soft-faced hammer so that there is no gap between it and the tank.

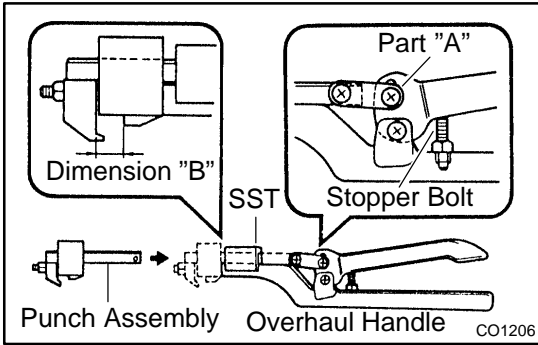

4. ASSEMBLE SST

SST 09230-01010, 09231-14010

- (a) Install the punch assembly to the overhaul handle, inserting it in the hole in part "A" as shown in the illustration.
- (b) While gripping the handle, adjust the stopper bolt so that dimension "B" shown in the diagram.

Dimension "B": 8.8 mm (0.35 in.)

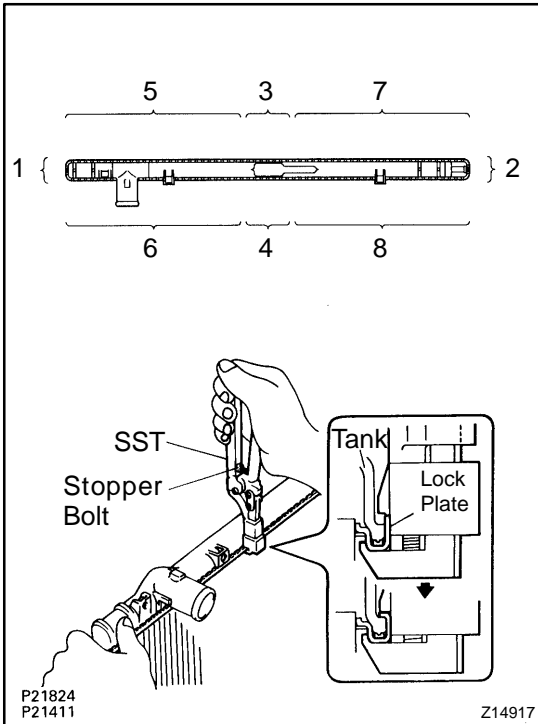

5. CAULK LOCK PLATE

- (a) Lightly press SST against the lock plate in the order shown in the illustration. After repeating this a few times, fully caulk the lock plate by squeezing the handle until stopped by the stopper bolt.

SST 09230-01010

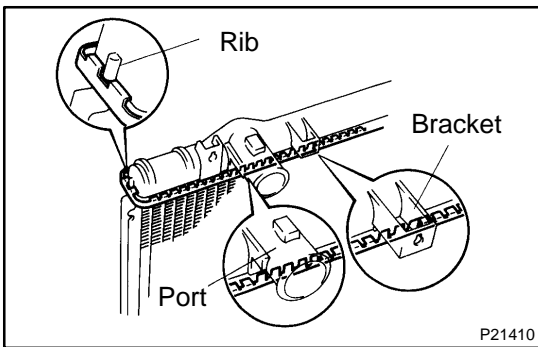

HINT:

- ◆ Do not stake the areas protruding around the ports, brackets or tank ribs.

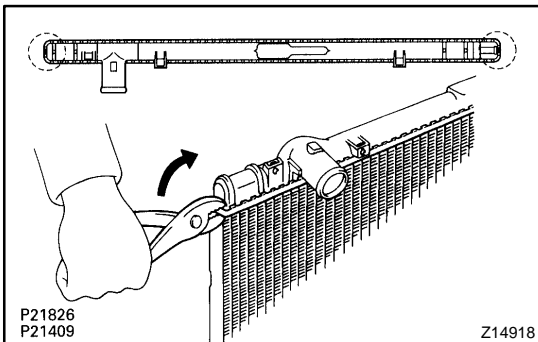

- ◆ The points shown in the rib sides and oil cooler near here cannot be staked with SST. Use pliers or similar object and be careful not to damage the core plates.

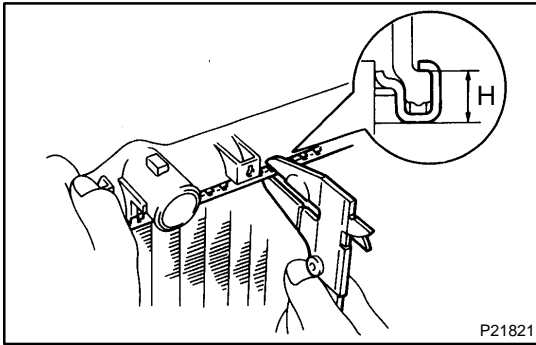

- (b) Check the lock plate height (H) after completing the caulking.

Plate height (H): 7.40 – 7.80 mm (0.2959 – 0.3119 in.)

If not within the specified height, adjust the stopper bolt of the handle again and caulk again.

6. PAINT LOCK PLATES

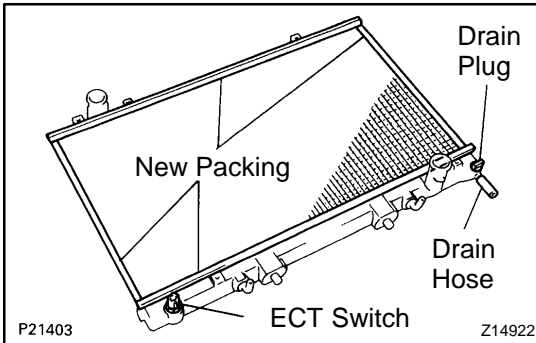

7. INSTALL ECT SWITCH FOR A/C COOLING FAN

- (a) Install a new O-ring to the ECT switch.
 (b) Apply soapy water to the O-ring.
 (c) Install the ECT switch.

Torque: 7.4 N·m (75 kgf·cm, 65 in.-lbf)

8. INSTALL DRAIN PLUG TO RADIATOR

- (a) Install a new O-ring to the drain plug.
 (b) Apply soapy water to the O-ring.
 (c) Install the drain plug.
 (d) Install the drain hose.

9. INSTALL PACKINGS

- (a) Install 4 new packings to the radiator rear side.
 (b) Install 2 new packings to the radiator front side.

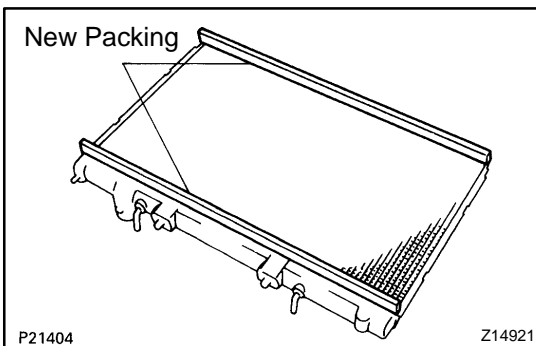

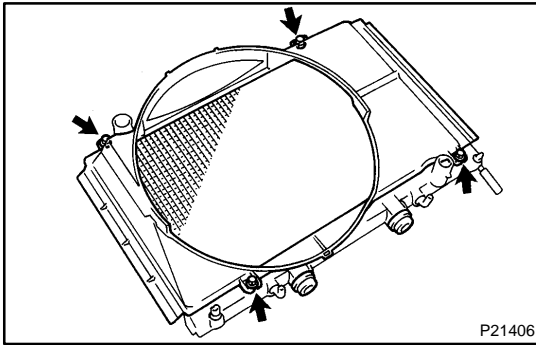

INSTALLATION

1. INSTALL NO.1 FAN SHROUD TO RADIATOR

Install the fan shroud with the 4 bolts.

Torque: 5.0 N·m (50 kgf·cm, 44 ft·lbf)

2. INSTALL RADIATOR ASSEMBLY

- (a) Install the 2 lower radiator supports to the radiator.
- (b) Place the radiator assembly on the body bracket.

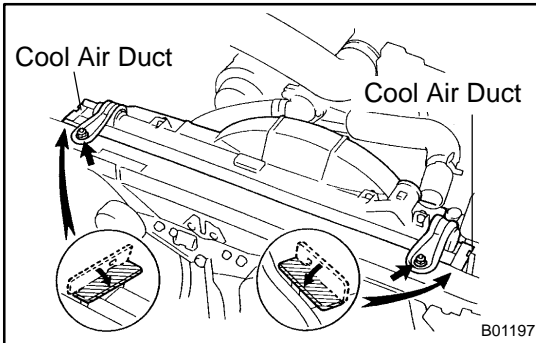

- (c) Install the radiator with the 2 upper radiator supports and 2 nuts.

Torque: 13.5 N·m (135 kgf·cm, 10 ft·lbf)

- (d) Install the upper sides of the RH and LH cool air ducts.
- (e) Connect the ECT switch connector for the A/C cooling fan.

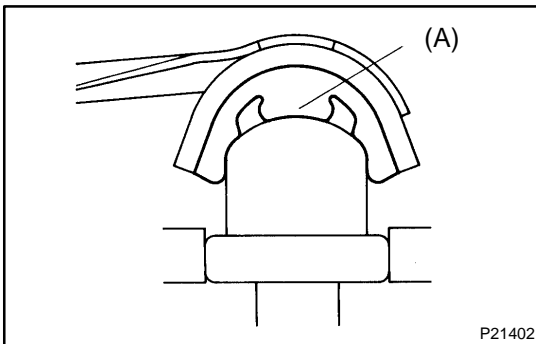

HINT:

After installation, check that the rubber cushion (A) of the support is depressed.

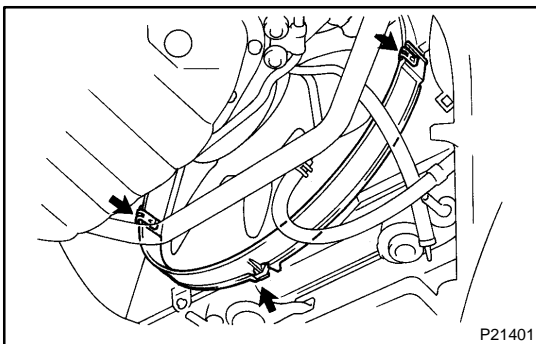

3. INSTALL NO.2 FAN SHROUD

- (a) Connect the claw of the No.2 fan shroud to the hook of the No.1 fan shroud.
- (b) Install the No.2 fan shroud with the 2 clips.

4. CONNECT UPPER RADIATOR HOSE TO RADIATOR
5. CONNECT LOWER RADIATOR HOSE TO RADIATOR
6. CONNECT A/T OIL COOLER HOSES TO RADIATOR
7. INSTALL RADIATOR RESERVOIR HOSE
8. FILL WITH ENGINE COOLANT
9. START ENGINE AND CHECK FOR LEAKS
10. RECHECK ENGINE COOLANT LEVEL
11. INSTALL AIR CLEANER INLET
12. INSTALL BATTERY CLAMP COVER
13. INSTALL ENGINE UNDER COVER
14. INSTALL OIL PAN PROTECTOR