

<b>DTC</b>	<b>P0440</b>	<b>Evaporative Emission Control System Malfunction</b>
------------	--------------	--

**CIRCUIT DESCRIPTION**

The vapor pressure sensor and VSV for vapor pressure sensor are used to detect abnormalities in the evaporative emission control system.

The ECM decides whether there is an abnormality in the evaporative emission control system based on the vapor pressure sensor signal.

DTC P0440 is recorded by the ECM when evaporative emissions leak from the components within the dotted line in fig. 1 below, or when the vapor pressure sensor malfunctions.

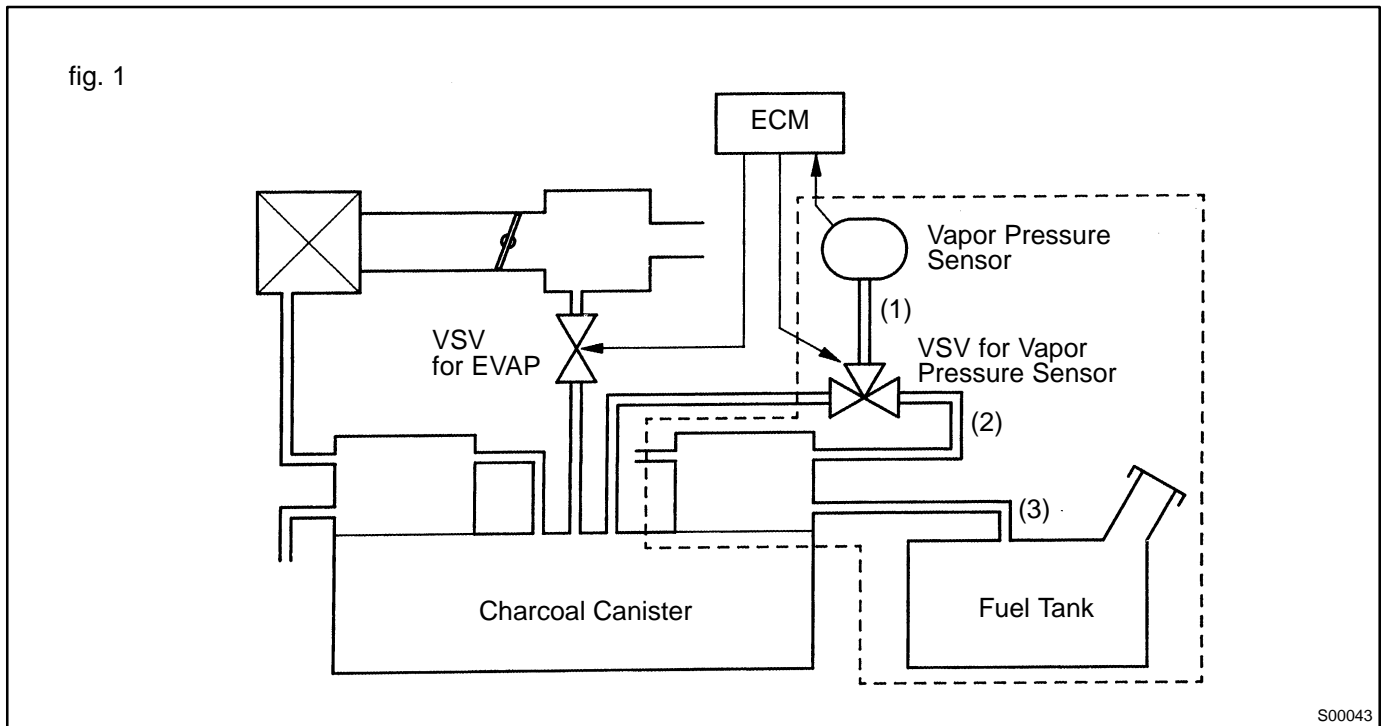

DTC No.	DTC Detecting Condition	Trouble Area
P0440	The fuel tank pressure is atmospheric pressure after the vehicle is driven for 20 min. (2 trip detection logic)	<ul style="list-style-type: none"> <li>• Vapor pressure sensor</li> <li>• Fuel tank cap incorrectly installed</li> <li>• Fuel tank cap cracked or damaged</li> <li>• Vacuum hose cracked, hole, blocked, damaged, or disconnected ((1) or (2) in fig. 1)</li> <li>• Hose or tube cracked, hole, damaged or loose seal ((3) in fig. 1)</li> <li>• Fuel tank cracked, hole or damaged</li> <li>• Charcoal canister cracked, hole or damaged</li> </ul>

## WIRING DIAGRAM

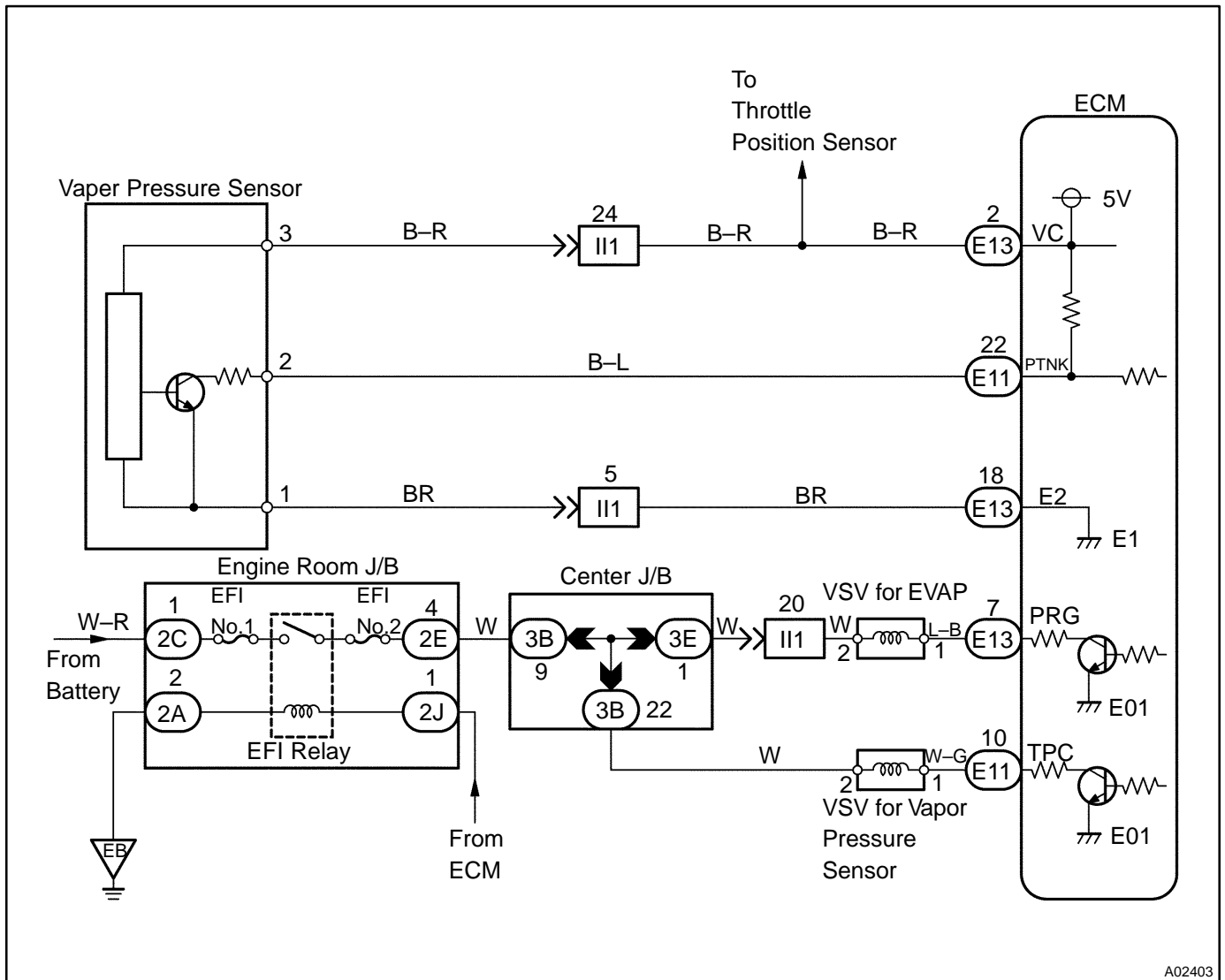

## INSPECTION PROCEDURE

- If DTC P0441, P0446, P0450 or P0451 is output after DTC P0440, first troubleshoot DTC P0441, P0446, P0450 or P0451. If no malfunction is detected, troubleshoot DTC P0440 next.
- Ask the customer whether, after the MIL came on, the customer found the fuel tank cap loose and tightened it. Also ask the customer whether the fuel tank cap was loose when refuelling. If the fuel tank cap was not loose, it was the cause of the DTC. If the fuel tank cap was not loose or if the customer was not sure if it was loose, troubleshoot according to the following procedure.
- Read freeze frame data using LEXUS hand-held tester or OBD II scan tool. Because freeze frame records the engine conditions when the malfunction is detected, when troubleshooting it is useful for determining whether the vehicle was running or stopped, the engine warmed up or not, the air-fuel ratio lean or rich, etc. at the time of the malfunction.
- When the ENGINE RUN TIME in the freeze frame data is less than 200 seconds, carefully check the VSV for EVAP, charcoal canister and vapor pressure sensor.

- 1 Check whether hose close to fuel tank have been modified, and check whether there are signs of any accident near fuel tank or charcoal canister.**

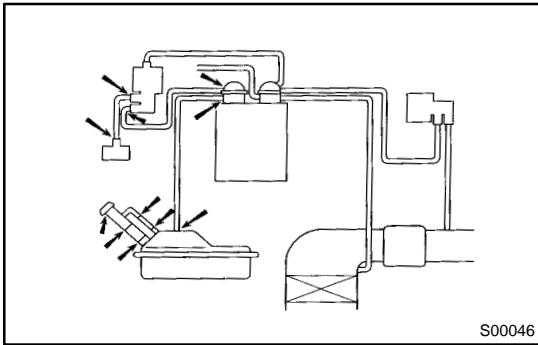
**CHECK:**

Check for cracks, deformation and loose connection of the following parts:

- Fuel tank
- Charcoal canister
- Fuel tank filler pipe
- Hoses and tubes around the fuel tank and charcoal canister

**NG****Repair or replace.****OK**

- 2 Check that fuel tank cap is LEXUS genuine parts.**

**NG****Replace to LEXUS genuine parts.****OK**

- 3 Check that fuel tank cap is correctly installed.**

**NG****Correctly install fuel tank cap.****OK**

- 4 Check fuel tank cap (See page [EC-5](#)).**

**NG****Replace fuel tank cap.****OK**

<b>5</b>	<b>Check filler neck for damage.</b>
----------	--------------------------------------

**PREPARATION:**

Remove the fuel tank cap.

**CHECK:**

Visually inspect the filler neck for damage.

<b>NG</b>	<b>Replace filler pipe.</b>
-----------	-----------------------------

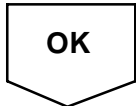

<b>6</b>	<b>Check vacuum hoses between vapor pressure sensor and VSV for vapor pressure sensor, and VSV for vapor pressure sensor and charcoal canister.</b>
----------	---

**CHECK:**

- (a) Check that the vacuum hose is connected correctly.
- (b) Check the vacuum hose for looseness and disconnection.
- (c) Check the vacuum hose for cracks, hole and damage.

<b>NG</b>	<b>Repair or replace.</b>
-----------	---------------------------



<b>7</b>	<b>Check hose and tube between fuel tank and charcoal canister.</b>
----------	---

**CHECK:**

- (a) Check for proper connection of the fuel tank and fuel evap pipe (See page [EC-5](#)), fuel evap pipe and fuel tube under the floor, fuel tube under the floor and charcoal canister.
- (b) Check the hose and tube for cracks, hole and damage.

<b>NG</b>	<b>Repair or replace.</b>
-----------	---------------------------

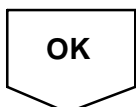

<b>8</b>	<b>Check charcoal canister for cracks, hole and damage (See page <a href="#">EC-5</a>).</b>
----------	---

<b>NG</b>	<b>Replace charcoal canister.</b>
-----------	-----------------------------------



**9 Check voltage between terminals VC and E2 of ECM connector.**

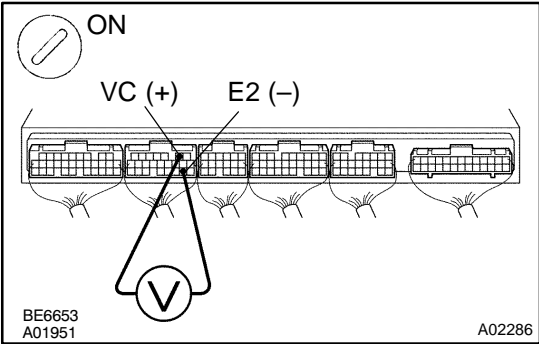

**CHECK:**

- (a) Remove the instrument panel under cover (See page SF-87).
- (b) Turn the ignition switch ON.

**CHECK:**

Measure voltage between terminals VC and E2 of the ECM connector.

**OK:**

**Voltage: 4.5 ~ 5.5 V**

**NG** Check and replace ECM (See page IN-30).

**OK**

**10 Check voltage between terminals PTNK and E2 of ECM connector.**

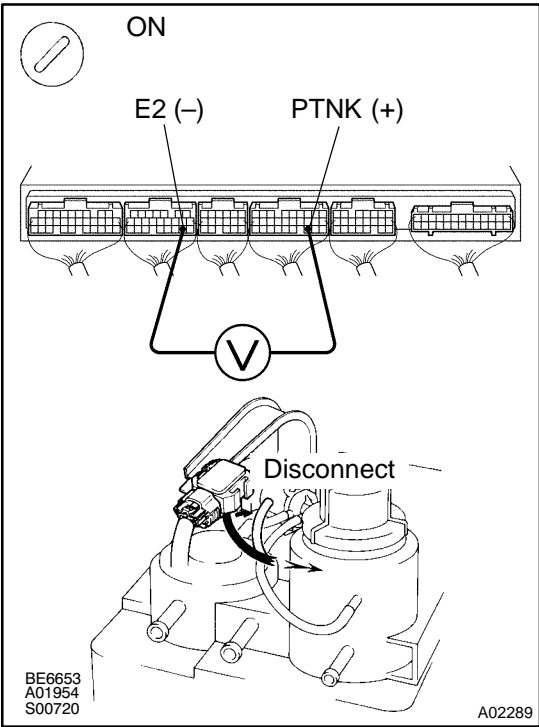

**PREPARATION:**

- (a) Remove the instrument panel under cover (See page SF-87).
- (b) Turn the ignition switch ON.

**CHECK:**

Measure voltage between terminals PTNK and E2 of the ECM connector.

- (1) Disconnect the vacuum hose from the vapor pressure sensor.
- (2) Using the MITYVAC (Hand-Held Vacuum Pump), apply a vacuum of 4.0 kPa (30 mmHg, 1.18 in.Hg) to the vapor pressure sensor.

**NOTICE:**

The vacuum applied to the vapor pressure sensor must be less than 66.7 kPa (500 mmHg, 19.7 in.Hg).

**OK:**

- (1) Voltage: 2.9 ~ 3.7 V
- (2) Voltage: 0.5 V or less

**OK** Go to step 12.

**NG**

- 11 Check for open and short in harness and connector between vapor pressure sensor and ECM (See page [IN-30](#)).

NG

Repair or replace harness or connector.

OK

Replace vapor pressure sensor.

- 12 Check fuel tank for cracks and damage.

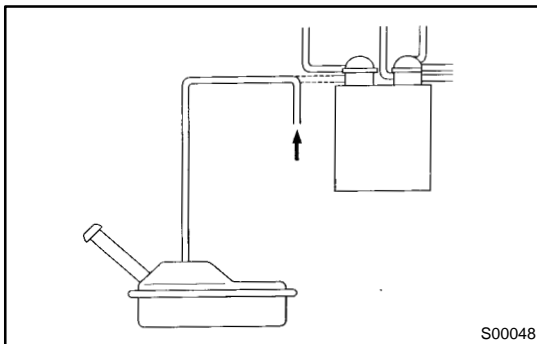
**PREPARATION:**

- Disconnect the vacuum hose from the charcoal canister.
- Correctly install the fuel cap.
- Apply a pressure of 5 kPa (50 gf/cm<sup>2</sup>, 0.7 psi) to the fuel tank.

**CHECK:**

Check whether the pressure is maintained after 1 minute.

**OK:**

Pressure applied to the fuel tank is maintained.

NG

Replace fuel tank.

OK

It is likely that vehicle user did not properly close fuel tank cap. Please explain to customer how to properly install fuel tank cap.