

ADJUSTMENT

NOTICE:

- Adjustment of the vehicle height should be performed with the height control switch in the **NORM** position. Perform height adjustments in a level place.
- Be sure to adjust the vehicle height so that it is within the range of standard values.
- Perform height adjustments in a level place.

1. INSPECT VEHICLE HEIGHT (See page SA-5)

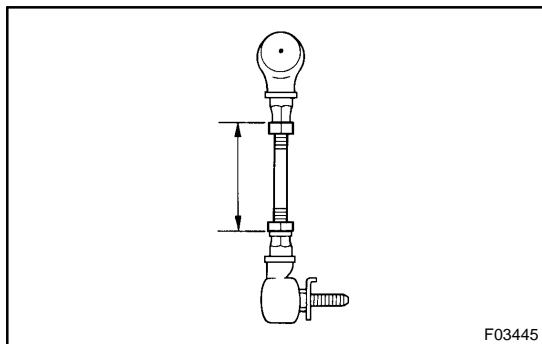

2. INSPECT FRONT HEIGHT CONTROL SENSOR LINK LENGTH

Inspect the link dimension shown in the illustration.

Link length (reference): 59.3 mm (2.335 in.)

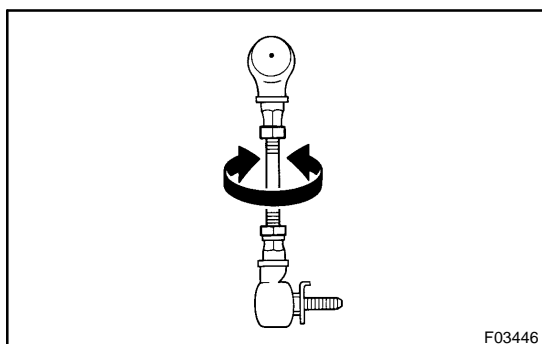

3. ADJUST FRONT VEHICLE HEIGHT

- Loosen the 2 lock nuts on the height control sensor link.
- Turn the bolt of the height control sensor link to adjust the length.

HINT:

Turning the bolt of the height control sensor link one revolution changes the vehicle height by about 5 mm (0.20 in.).

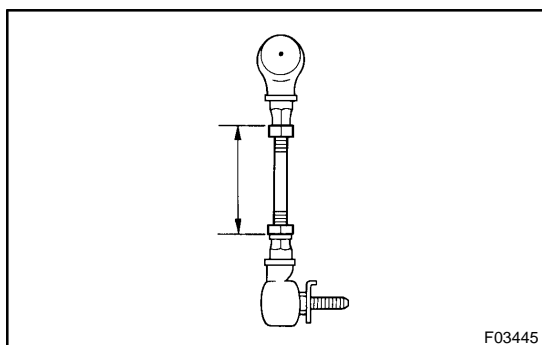

- Check if the height control sensor link dimension shown in the illustration is less than the maximum value.

Maximum: 10 mm (0.39 in.)

- Tighten the 2 lock nuts temporarily.

HINT:

Coat the thread of the bolt with sealer.

Sealer:

Part No.08833-00070, THREE BOND 1324 or equivalent

- Inspect the vehicle height one more time.
- Tighten the lock nuts.

Torque: 4.9 N·m (50 kgf·cm, 43 in.-lbf)

NOTICE:

Make sure the ball joint and bracket are parallel when tightening the lock nuts.

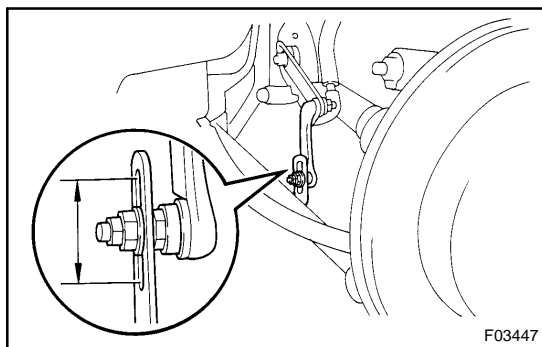

4. ADJUST REAR VEHICLE HEIGHT

The rear vehicle height can be adjusted by moving the installation position of the link on the lower arm.

When the link is moved 1 mm (0.04 in.), the vehicle height is adjusted by about 2 mm (0.08 in.).

5. INSPECT WHEEL ALIGNMENT (See page SA-5)