

INSPECTION

1. FAIL-SAFE FUNCTION (Light Control ECU)

<p>When input error is inspected.</p>	<p>When input voltage is not within the range of operation voltage (9 to 16 V), lighting of the headlight stops. As soon as the voltage comes within the range, it lit up again. However if the input voltage becomes low after lighting up, sufficient voltage is maintained until light of bulb completely goes off.</p>
<p>When output error is inspected (Open or short). When light flushing is inspected.</p>	<p>When an error occurs in the output voltage (open or short) or flushing symptom occurs on the bulb, lighting of the headlight stops, the condition is maintained until power is turned ON again (headlight dimmer switch OFF → ON). In this case, it can not be judged whether lighting malfunction is caused by an output error or other reasons (fuse blown out, etc.). Check that there is no error in fuse and wiring (including power source) and replace the bulb in the first place, when the error still appears, replace the light control ECU.</p>

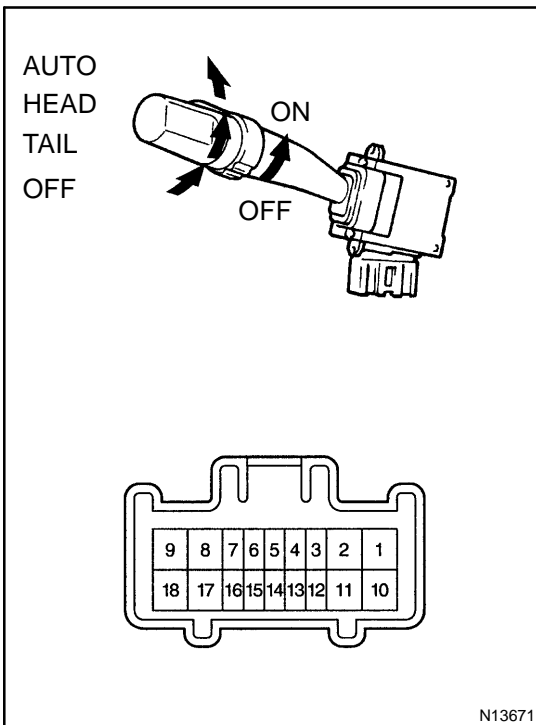

2. INSPECT LIGHT CONTROL SWITCH CONTINUITY

Switch position	Tester connection	Specified condition
OFF	-	No continuity
TAIL	15 - 16	Continuity
HEAD	14 - 15 - 16	Continuity
AUTO	13 - 16	Continuity

If continuity is not as specified, replace the switch.

3. INSPECT FOG LIGHT SWITCH CONTINUITY

Switch position	Tester connection	Specified condition
OFF	-	No continuity
ON	11 - 12	Continuity

If continuity is not as specified, replace the switch.

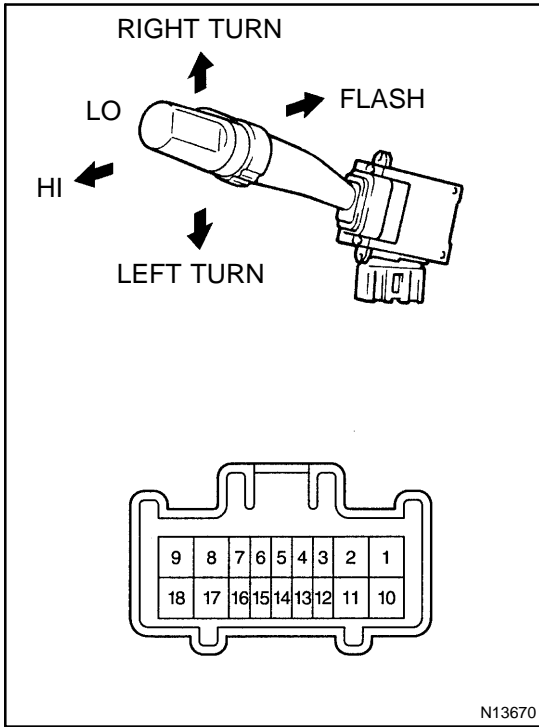

N13670

4. INSPECT HEADLIGHT DIMMER SWITCH CONTINUITY

Switch position	Tester connection	Specified condition
Flash	8 - 9 - 17	Continuity
Low beam	17 - 18	Continuity
High beam	8 - 17	Continuity

If continuity is not as specified, replace the switch.

5. INSPECT TURN SIGNAL SWITCH CONTINUITY

Switch position	Tester connection	Specified condition
Left turn	1 - 2	Continuity
Neutral	-	No continuity
Right turn	2 - 3	Continuity

If continuity is not as specified, replace the switch.

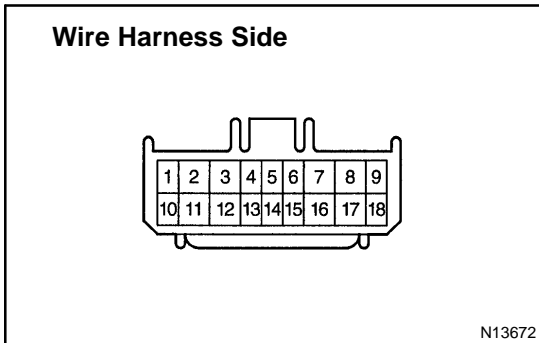

N13672

6. USA: INSPECT SWITCH CIRCUIT

- (a) Disconnect the connector from the switch and inspect the connector on the wire harness side, as shown.

Light Control Switch Circuit

Tester connection	Condition	Specified condition
16 - Ground	Constant	Continuity

Fog Light Switch Circuit

Tester connection	Condition	Specified condition
11 - 18	Constant	Continuity
12 - Ground	Constant	Battery positive voltage

Dimmer Switch Circuit

Tester connection	Condition	Specified condition
17 - Ground	Constant	Continuity
9 - Ground	Constant	Battery positive voltage

Turn Signal Switch Circuit

Tester connection	Condition	Specified condition
2 - Ground	Constant	Continuity

If the circuit is not as specified, inspect the wire harness.

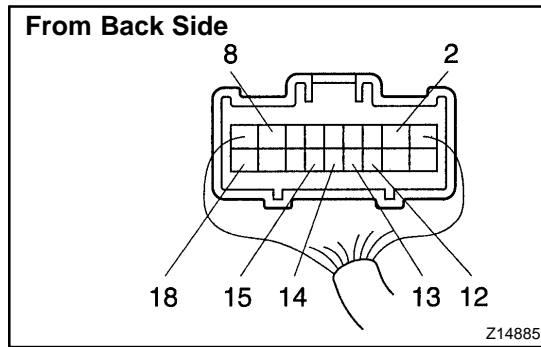

(b) Connect the wire harness side connector to the light control switch and inspect the connector from the back side, as shown.

Light Control Switch Circuit
See page [DI-687](#)

Fog Light Switch Circuit

Tester connection	Condition	Specified condition
12 - Ground	Light control switch HEAD and dimmer switch position HI or FLASH	No voltage
12 - Ground	Light control switch HEAD and dimmer switch position LO	Battery positive voltage

Dimmer Switch Circuit

Tester connection	Condition	Specified condition
8 - Ground	Light control switch HEAD and dimmer switch LOW	No voltage
8 - Ground	Headlight dimmer switch FLASH or Light control switch HEAD and dimmer switch HIGH	Battery positive voltage
18 - Ground	Light control switch HEAD and dimmer switch HIGH or FLASH	No voltage
18 - Ground	Light control switch HEAD and dimmer switch LOW	Battery positive voltage

Turn Signal Switch Circuit

Tester connection	Condition	Specified condition
1 - Ground	Ignition switch ON and turn signal switch position Left	Battery positive voltage
3 - Ground	Ignition switch ON and turn signal switch position Right	Battery positive voltage

If the circuit is not as specified, inspect the circuits connected to other parts.

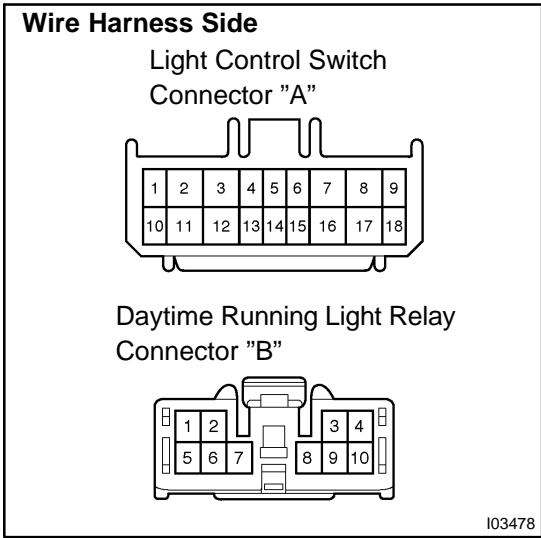

- 7. CANADA:**
INSPECT SWITCH CIRCUIT
- (a) Disconnect the light control switch and daytime running light relay connectors, and inspect the each connector on the wire harness side, as shown.

Light Control Switch Circuit

Tester connection	Condition	Specified condition
A16 - Ground	Constant	Continuity

Dimmer Switch Circuit

Tester connection	Condition	Specified condition
A17 - Ground	Constant	Continuity
A8 - B8	Constant	Continuity
A9 - B2	Constant	Continuity

If the circuit is not as specified, inspect the wire harness.

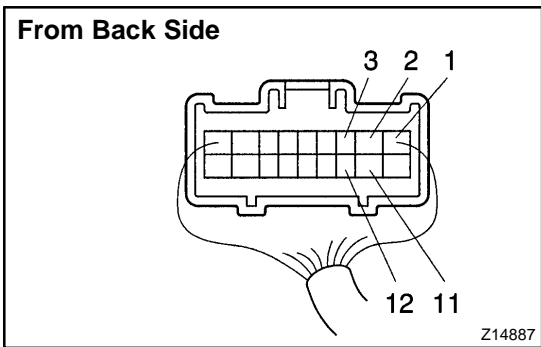

- (b) Connect the wire harness side connector to the light control switch and inspect the connector from the back side, as shown.

Fog Light Switch Circuit

Tester connection	Condition	Specified condition
11 - Ground	Light control switch OFF	No voltage
11 - Ground	Light control switch TAIL, HEAD or AUTO and Fog light switch ON	Battery positive voltage
12 - Ground	Light control switch OFF	No voltage
12 - Ground	Light control switch TAIL, HEAD or AUTO	Battery positive voltage

Turn Signal Switch Circuit

Tester connection	Condition	Specified condition
2 - Ground	Constant	Continuity
1 - Ground	Ignition switch ON and Turn signal switch position Left	No voltage
3 - Ground	Ignition switch ON and Turn signal switch position Right	Battery positive voltage

If the circuit is not as specified, inspect the circuits connected to other parts.

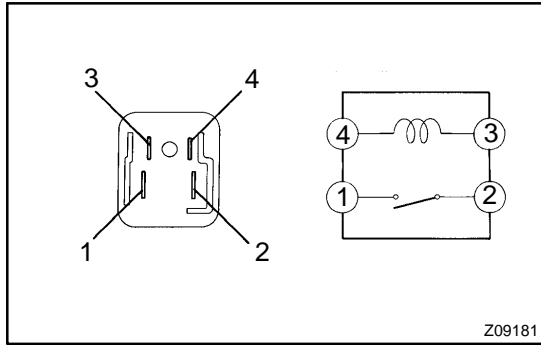

8. INSPECT HEADLIGHT CONTROL RELAY CONTINUITY

Condition	Tester connection	Specified condition
Constant	3 - 4	Continuity
Apply B+ between terminals 3 and 4.	1 - 2	Continuity

If continuity is not as specified, replace the relay.

9. INSPECT HEADLIGHT CONTROL RELAY CIRCUIT (See page BE-23)

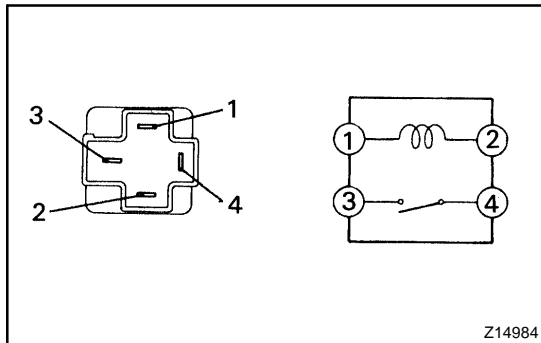

10. INSPECT TAILLIGHT CONTROL RELAY CONTINUITY

Condition	Tester connection	Specified condition
Constant	1 - 2	Continuity
Apply B+ between terminals 1 and 2.	3 - 4	Continuity

If continuity is not as specified, replace the relay.

11. INSPECT TAILLIGHT CONTROL RELAY CIRCUIT (See page BE-23)

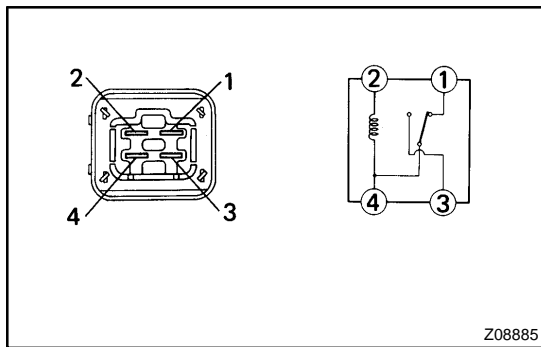

12. INSPECT HEADLIGHT DIMMER AND DAYTIME RUNNING LIGHT NO.2 RELAY CONTINUITY

Condition	Tester connection	Specified condition
Constant	1 - 4 2 - 4	Continuity
Apply B+ between terminals 2 and 4.	3 - 4	Continuity

If continuity is not as specified, replace the relay.

13. INSPECT HEADLIGHT DIMMER RELAY CIRCUIT (See page BE-23)

Wire Harness Side

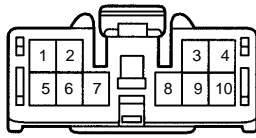

h-10-1-A

N21564

14. INSPECT DAYTIME RUNNING LIGHT RELAY CIRCUIT

Disconnect the connector from the relay and inspect the connector on the wire harness side.

Tester connection	Condition	Specified condition
2 - Ground	Light control switch position OFF or TAIL	No continuity
2 - Ground	Light control switch position HEAD	Continuity
4 - Ground	Parking brake switch position OFF (Parking brake lever released)	No continuity
4 - Ground	Parking brake switch position ON (Parking brake lever pulled up)	Continuity
6 - Ground	Constant	Continuity
8 - Ground	Headlight dimmer switch position Low beam	No continuity
8 - Ground	Headlight dimmer switch position High beam or Flash	Continuity
10 - Ground	Brake fluid level warning switch position OFF	No continuity
10 - Ground	Brake fluid level warning switch position ON	Continuity
1 - Ground	Ignition switch position LOCK or ACC	No voltage
1 - Ground	Ignition switch position ON or START	Battery positive voltage
5 - Ground	Engine Stop	No voltage
5 - Ground	Engine Running	Battery positive voltage
7 - Ground	Constant	Battery positive voltage
9 - Ground	Constant	Battery positive voltage

If circuit is as specified, try replacing the relay with a new one. If circuit is not as specified, inspect the circuits connected to other parts.

15. INSPECT DAYTIME RUNNING LIGHT RELAY NO.3 AND NO.4 CONTINUITY

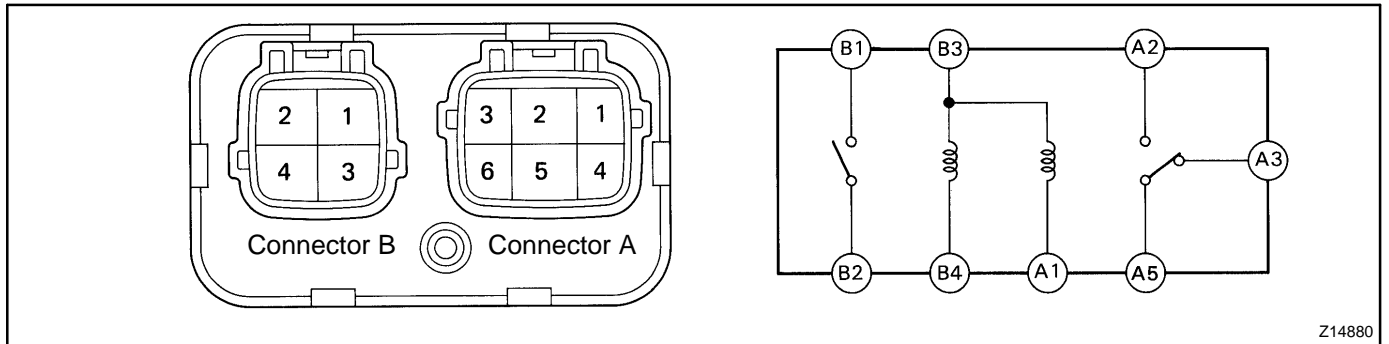

Z14880

Tester connection	Condition	Specified condition
A1 - B3	Constant	Continuity
A3 - A5	Constant	Continuity
B3 - B4	Constant	Continuity
A2 - A5	Apply battery positive voltage between terminal A1 and B3.	Continuity
B1 - B2	Apply battery positive voltage between terminal B3 and B4.	Continuity

If continuity is not as specified, replace the relay.

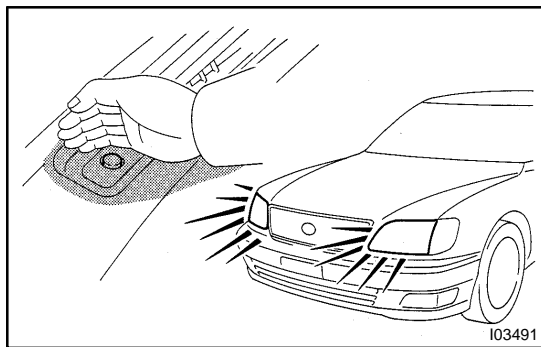

16. INSPECT AUTOMATIC LIGHT CONTROL AUTO ON:

- (a) Turn the ignition switch ON.
- (b) Turn the light control switch to AUTO.
- (c) Gradually cover the top of the sensor.
- (d) Verify that the lights should turn ON the accessory lights and the headlights.

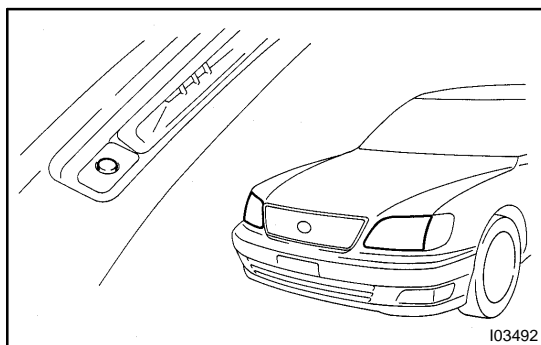

17. INSPECT AUTOMATIC LIGHT CONTROL AUTO OFF:

- (a) Gradually expose the sensor.
- (b) Verify that the lights should turn OFF the headlights and the accessory lights.

18. INSPECT LIGHT-OFF CONDITION

- (a) Turn the ignition switch ON.
- (b) Gradually cover the top of the sensor.
Lights auto ON:
- (c) Verify that the lights will go out when light control switch position OFF or the area surrounding the sensor gets bright or open the driver's door while the ignition switch is OFF.

19. INSPECT LIGHTS-ON CONDITION

- (a) Open the driver's door while the ignition switch is OFF.
- (b) Turn the light control switch to AUTO leaving the door open and cover the top of the sensor, and verify that the lights go on when the ignition switch is turned ON.

20. ADJUST AUTOMATIC LIGHT CONTROL SENSOR

Using the LEXUS hand-held tester with customize soft installed, adjust the automatic light control sensor.

- If response is too quick, turn the knob counterclockwise.
- If response is too slow, turn the knob clockwise.

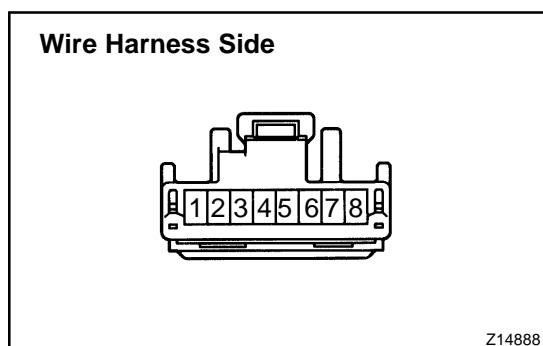
**21. INSPECT AUTOMATIC LIGHT CONTROL SENSOR CIRCUIT****Connector disconnected**

Disconnect the connector from the sensor and inspect the connector on the wire harness side, as shown in the chart.

Tester connection	Condition	Specified condition
6 - Ground	Constant	Continuity
4 - Ground	Ignition switch position LOCK or ACC	No voltage
4 - Ground	Ignition switch position ON	5.2 - 9.0 V
5 - Ground	Ignition switch position LOCK or ACC	No voltage
5 - Ground	Ignition switch position ON	Battery positive voltage

If circuit is as specified, perform the inspection on the following page.

If the circuit is not as specified, inspect the circuit connected to other parts.

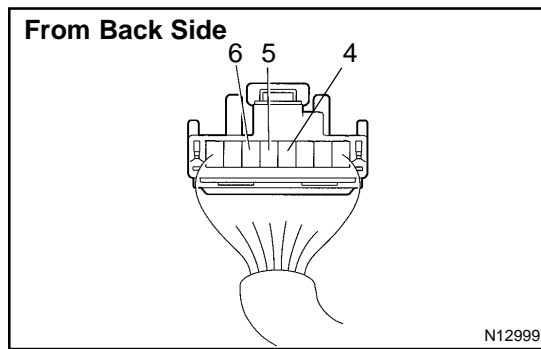
**Connector connected**

Connect the wire harness side connector to the sensor and inspect wire harness side connector from the back side, as shown.

HINT:

- Ignition switch ON.
- Light control switch AUTO.
- Vehicle's surroundings are bright.

Tester connection	Condition	Specified condition
6 - Ground	Constant	1 V or less
5 - Ground	Ignition switch position LOCK or ACC	1 V or less
5 - Ground	Ignition switch position ON	9.5 V or more
4 - Ground	Vehicle's surroundings are dark. (Sensor is covered)	Taillight and headlight are ON

If circuit is as specified, try replacing the sensor with a new one.
If the circuit is not as specified, inspect the circuit connected to other parts.