

DTC	B1422	Compressor Lock Sensor Circuit
------------	--------------	---------------------------------------

CIRCUIT DESCRIPTION

This sensor sends 4 pluses per engine revolution to the A/C control assembly.

If the number ratio of the compressor speed divided by the engine speed is smaller than a predetermined value, the A/C control assembly turns the compressor off. And, the indicator flashes at about 1 second intervals.

DTC No.	Detection Item	Trouble Area
B1422	All conditions below are detected for 3 secs. or more (a) Engine speed : 450 rpm or more (b) Ratio between engine and compressor speed deviates 20% or more in comparison to normal operation.	<ul style="list-style-type: none"> • Compressor. • Compressor drive belt. • Compressor lock sensor. • Harness and connector between compressor and A/C control assembly. • A/C control assembly.

WIRING DIAGRAM

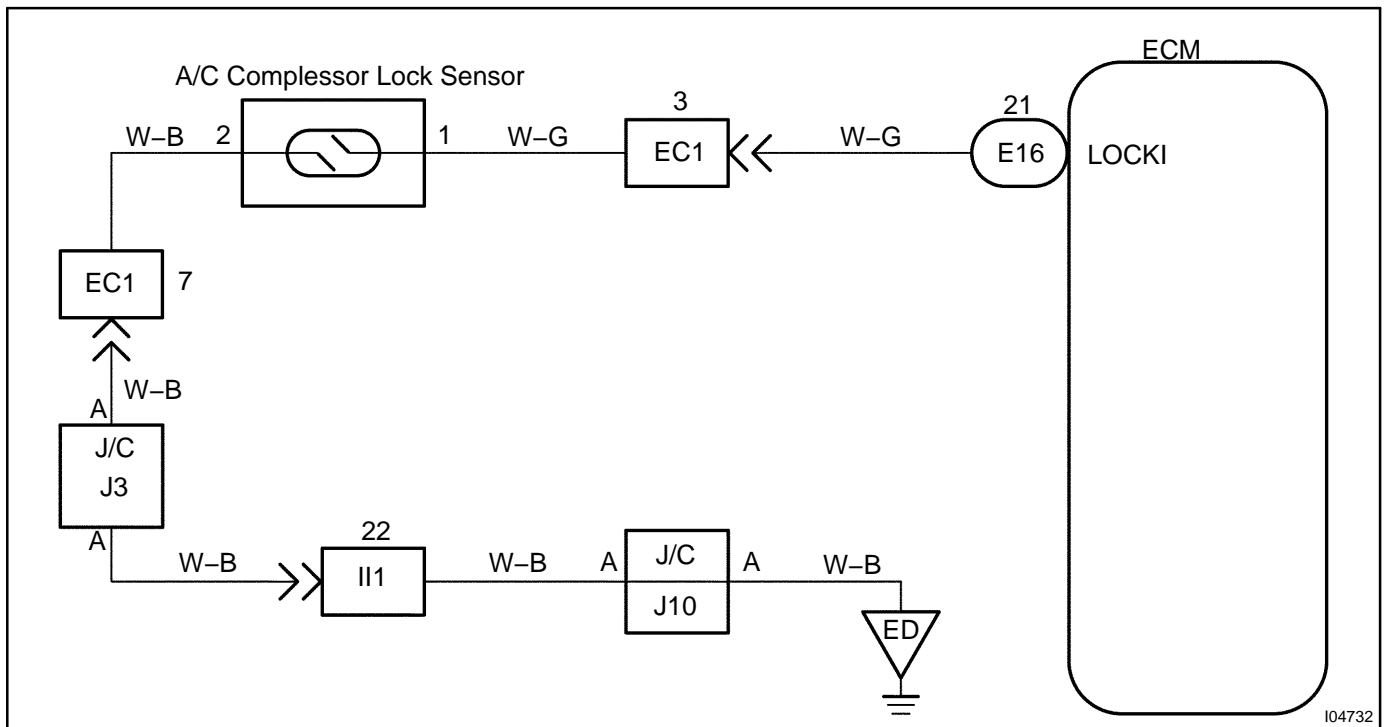

104732

INSPECTION PROCEDURE

1	Check compressor.
----------	--------------------------

PREPARATION:

- (a) Check compressor drive belt tension (See page [AC-14](#)).
- (b) Check if the compressor does not lock during operation with engine started and blower switch and A/C switch ON.

NG

Adjust drive belt tension or repair compressor.

OK

2	Check compressor lock sensor.
----------	--------------------------------------

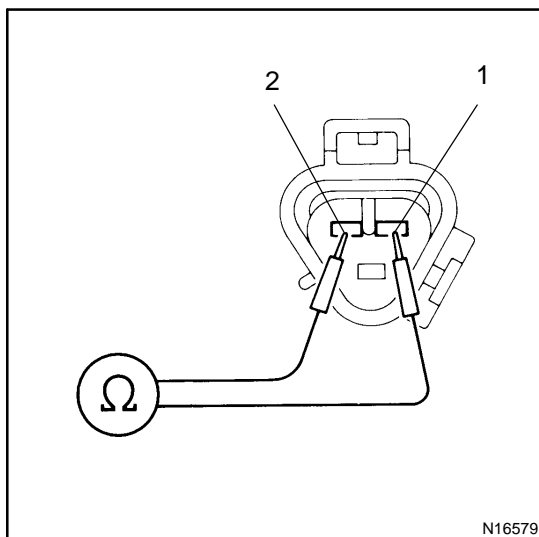

PREPARATION:

- (a) Jack up the vehicle.
- (b) Disconnect compressor lock sensor connector.

CHECK:

Measure resistance between terminals 1 and 2 of duct compressor lock sensor connector.

OK:

Resistance

at 20°C (68°F) : 1050 ~ 570 Ω

at 100°C (212°F) : 1440 ~ 720 Ω

NG

Replace compressor lock sensor.

OK

3	Check harness and connectors between A/C control assembly and compressor lock sensor (See page IN-30).
----------	---

NG

Repair or replace harness or connector.

OK

Proceed to next circuit inspection shown on problem symptoms table (See page [DI-952](#)). However, if DTC B1422 is displayed, check and replace A/C control assembly.