

REMOVAL AND INSTALLATION OF COMPONENT PARTS

Steering Wheel Pad and Spiral Cable

Remove and install the parts as shown.

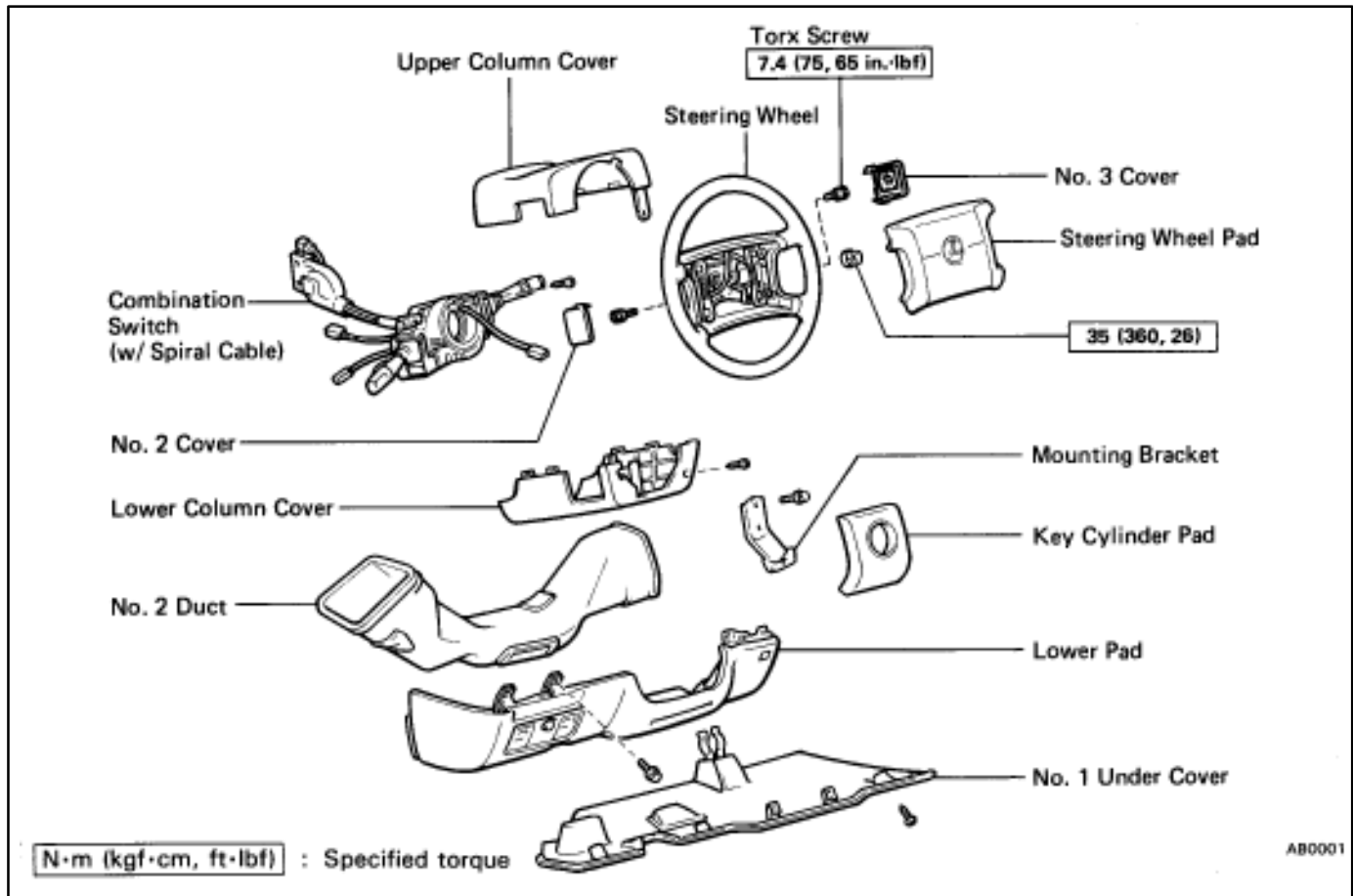

(MAIN POINTS OF REMOVAL AND INSTALLATION)

CAUTION: Work must be started after approx. 30 seconds or longer from the time the ignition switch is turned to the LOCK position and the negative (-) terminal cable is disconnected from the battery (See page AB-2).

NOTICE:

- If the wiring connector of the airbag system is disconnected with the ignition switch at ON or ACC, diagnostic codes will be recorded.
- Never use airbag parts from another vehicle. When replacing parts, replace with new parts.

1. REMOVE STEERING WHEEL PAD

- Remove negative terminal (-) from the battery.
- Place the front wheels facing straight ahead.
- Using a torx wrench, loosen the four screws.
Torx wrench: T30 (Part No. 09042-00010 or locally manufactured tool)
- Loosen the torx screws until the groove along the screw circumference catches on the screw case.

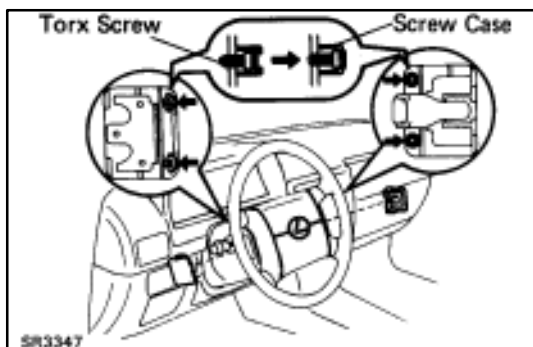

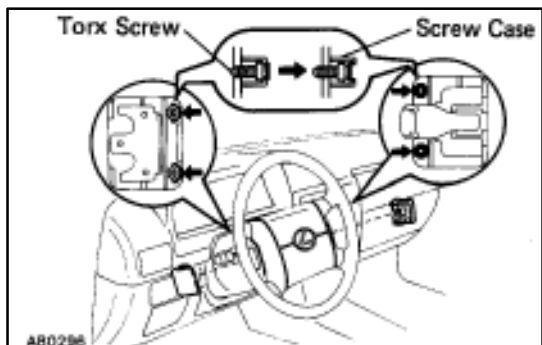
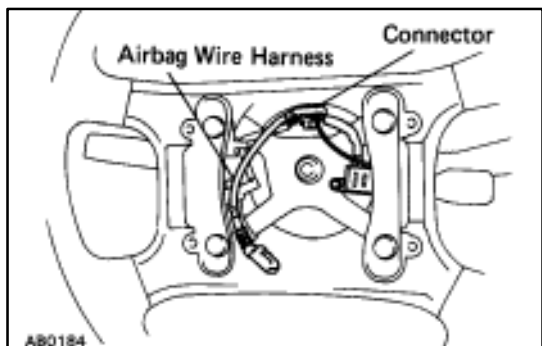
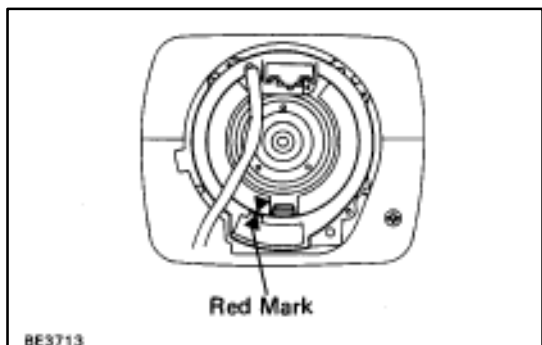
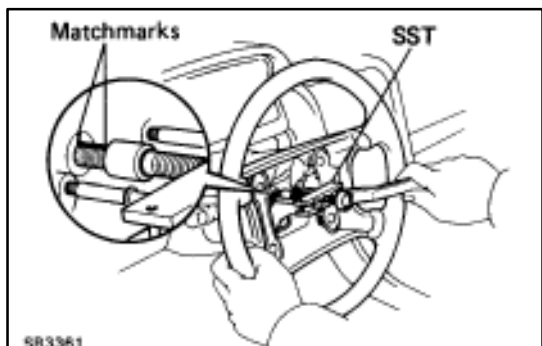
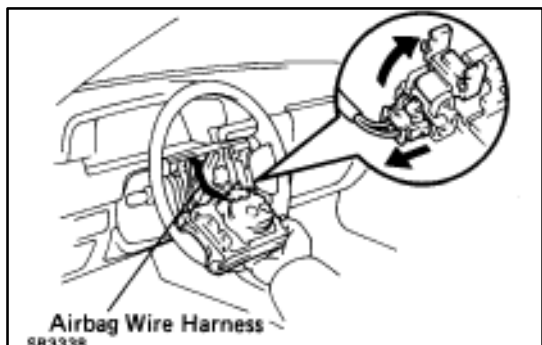

(e) Pull the wheel pad out from the steering wheel and disconnect the airbag connector.

NOTICE: When removing the wheel pad, take care not to pull the airbag wire harness.

CAUTION:

- When storing the wheel pad, keep the upper surface of the pad facing upward (See pages AB-3,4).
- Never disassemble the wheel pad.

2. REMOVE STEERING WHEEL

- Disconnect the connector.
- Remove the set nut.
- Place matchmarks on the steering wheel and main shaft.
- Using SST, remove the steering wheel.
SST 09213-31021

3. REMOVE AND INSTALL SPIRAL CABLE FROM/TO COMBINATION SWITCH
(See page BE-37)

NOTICE: Do not disassemble the spiral cable or apply oil to it.

4. CENTER SPIRAL CABLE

- Check that the front wheels are facing straight ahead.
- Turn the spiral cable counterclockwise by hand until it becomes harder to turn the cable.
- Then rotate the spiral cable clockwise about 2 1/2 turns to align the red mark.

HINT: The spiral cable will rotate about 2 1/2 turns to either left or right of the center.

5. INSTALL STEERING WHEEL

- Align matchmarks on the steering wheel and main shaft, and install the steering wheel to the main shaft.
- Install and torque the set nut.

Torque: 35 N·m (360 kgf·cm, 26 ft·lbf)

- Connect the connector.

6. INSTALL STEERING WHEEL PAD

- Connect the airbag connector.
- Install the wheel pad after confirming that the circumference groove of the torx screws is caught on the screw case.
- Using a torx wrench, tighten the four screws.

Torque: 7.4 N·m (75 kgf·cm, 65 in·lbf)

NOTICE:

- Make sure the wheel pad is installed to the specified torque.
- If the wheel pad has been dropped, or there are cracks, dents or other defects in the case or connector, replace the wheel pad with a new one.
- When installing the wheel pad, take care that the wirings do not interfere with other parts and are not pinched between other parts.

7. CHECK STEERING WHEEL CENTER POINT