

# REAR BUMPER COMPONENTS

76157-01

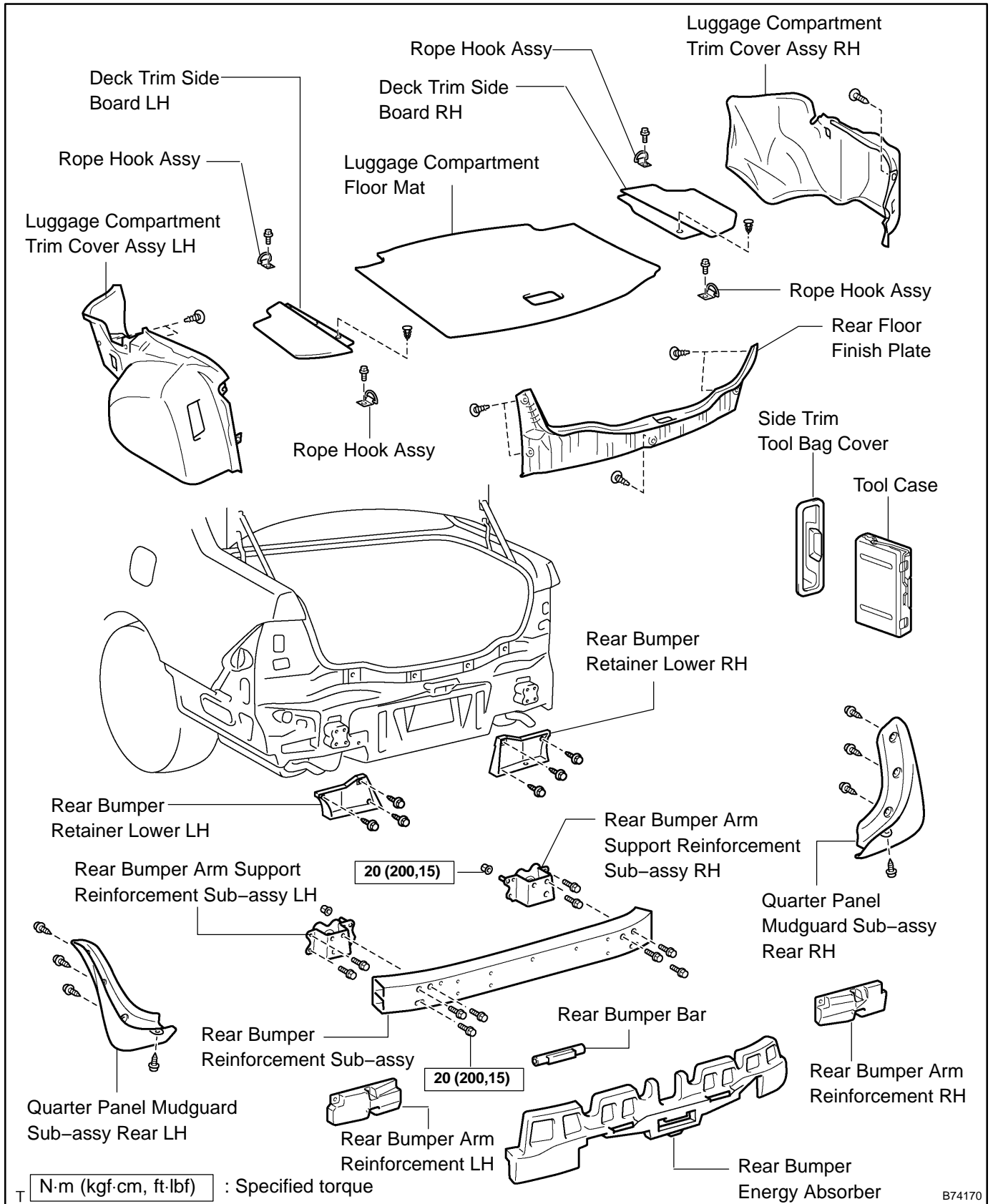

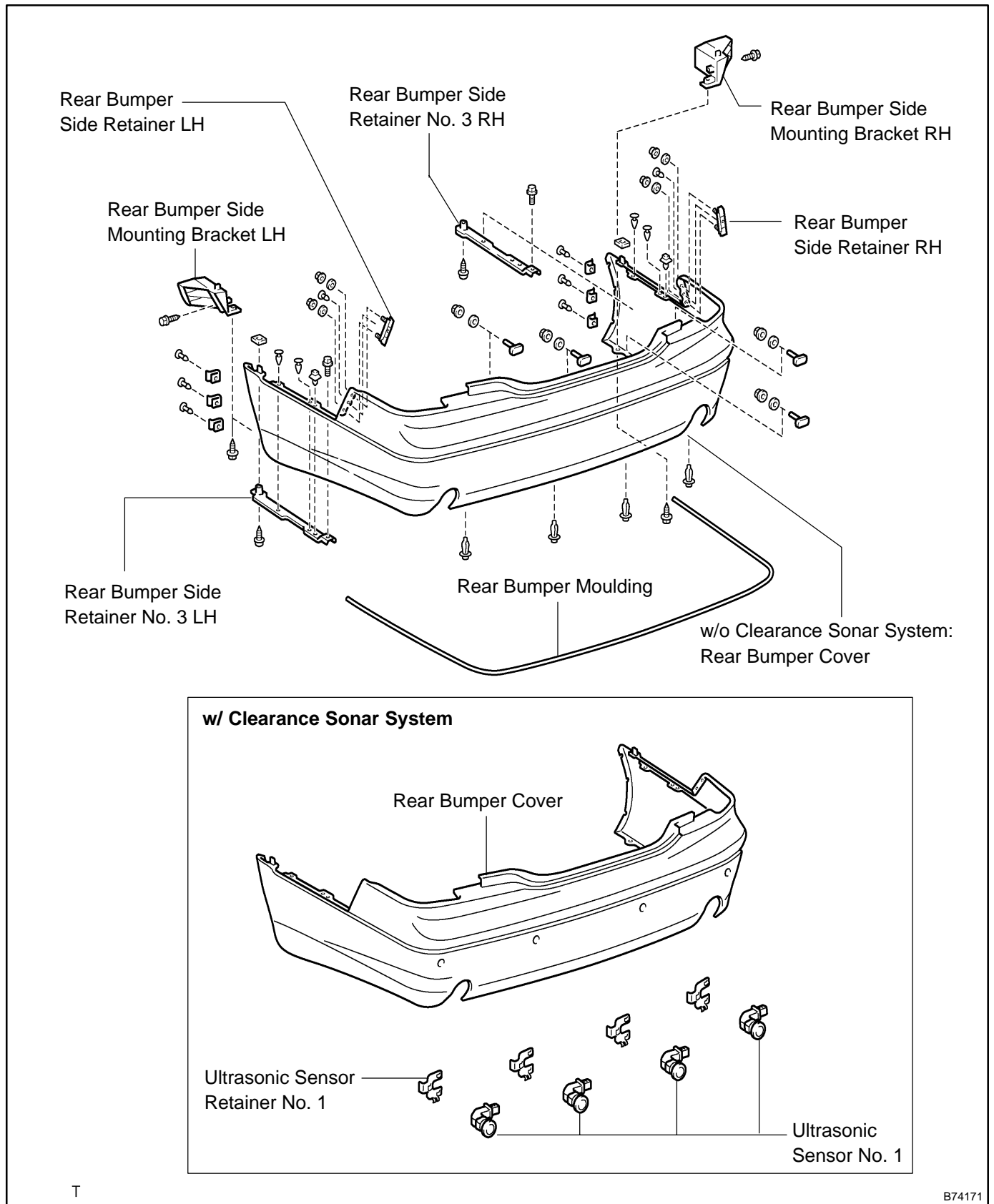

T

B74171

## REPLACEMENT

### HINT:

- The installation procedures are the removal procedures in reverse order. However, only installation procedures requiring additional information are included.
  - A bolt without a torque specification is shown in the standard bolt chart (see page 03-2).
1. **REMOVE LUGGAGE COMPARTMENT FLOOR MAT**
  2. **REMOVE ROPE HOOK ASSY**
    - (a) Remove the 4 bolts and 4 hooks.
  3. **REMOVE DECK TRIM SIDE BOARD LH**
  4. **REMOVE DECK TRIM SIDE BOARD RH**

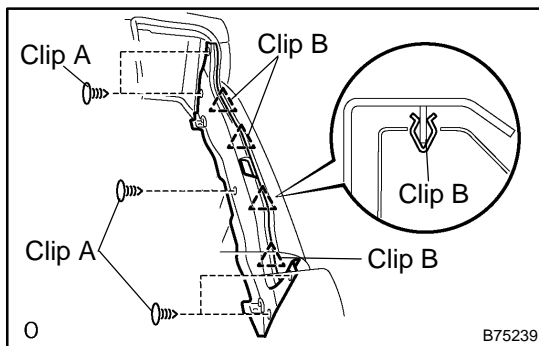

### 5. REMOVE REAR FLOOR FINISH PLATE

- (a) Using a clip remover, remove the 5 clips labeled A.
- (b) Using a screwdriver, disengage the 4 clips labeled B and remove the finish plate.

### HINT:

Tape the screwdriver tip before use.

### 6. REMOVE TOOL CASE

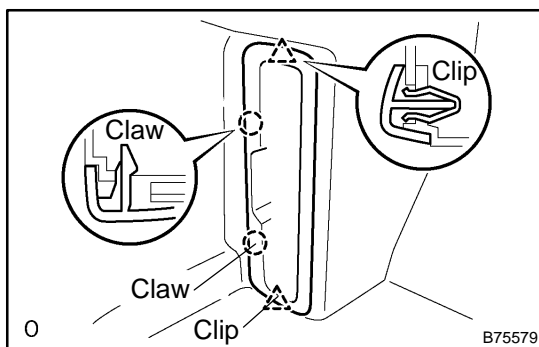

### 7. REMOVE SIDE TRIM TOOL BAG COVER

- (a) Using a screwdriver, disengage the 2 claws and 2 clips and remove the cover.

### HINT:

Tape the screwdriver tip before use.

8. **REMOVE LUGGAGE COMPARTMENT TRIM COVER ASSY LH (See page 75-55)**
9. **REMOVE LUGGAGE COMPARTMENT TRIM COVER ASSY RH (See page 75-55)**
10. **REMOVE QUARTER PANEL MUDGUARD SUB-ASSY REAR LH (W/ MUDGUARD)**
  - (a) Remove the 4 screws and mudguard.
11. **REMOVE QUARTER PANEL MUDGUARD SUB-ASSY REAR RH (W/ MUDGUARD)**
  - (a) Remove the 4 screws and mudguard.

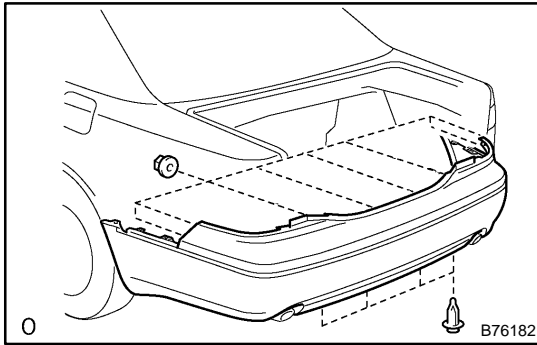
**12. REMOVE REAR BUMPER COVER**

- (a) Using a screwdriver, remove the 4 clips.

HINT:

Tape the screwdriver tip before use.

- (b) Remove the 8 nuts.

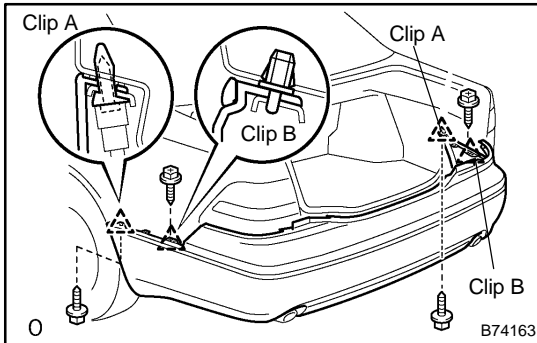

- (c) Remove the 2 bolts and 2 screws.

- (d) Using a screwdriver, disengage the 2 clips labeled A and 2 clips labeled B. Then remove the bumper cover.

- (e) w/ Clearance sonar system:  
Disconnect the 4 sensor connectors.

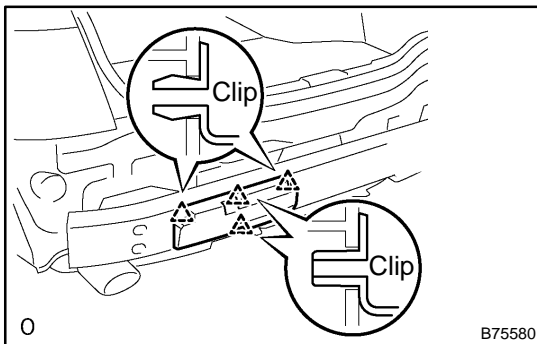
**13. REMOVE REAR BUMPER ENERGY ABSORBER****14. REMOVE REAR BUMPER BAR****15. REMOVE REAR BUMPER ARM REINFORCEMENT LH**

- (a) Using a screwdriver, disengage the 4 clips and remove the arm reinforcement.

HINT:

Tape the screwdriver tip before use.

**16. REMOVE REAR BUMPER ARM REINFORCEMENT RH**

HINT:

Use the same procedures described for the LH side.

**17. REMOVE REAR BUMPER REINFORCEMENT SUB-ASSY**

- (a) Remove the 6 bolts and reinforcement.

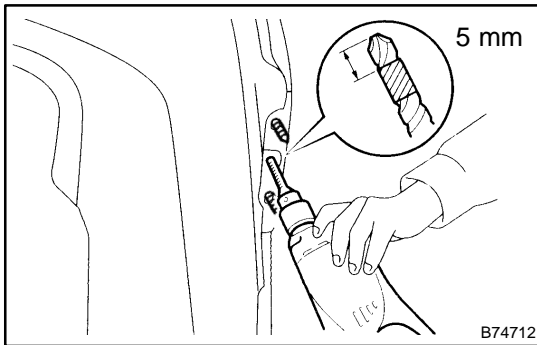
**18. REMOVE REAR BUMPER SIDE RETAINER LH**

- (a) Use a drill that has a tip of less than  $\phi$  4 mm (0.16 in.).
- (b) Tape the drill tip as shown in the illustration.

**Dimension: 5 mm (0.20 in.)**

**HINT:**

Taping the drill tip is done to prevent excessive drilling.

- (c) Gently place the drill tip onto the rivet, cut the rivet flanges and then remove the rivet.

**NOTICE:**

- Pressing the drill tip onto the rivet strongly will cause the rivet to turn with the drill and the rivet will not be cut.
  - Do not prize the rivet hole with the drill. Doing so may damage the rivet hole and/or the drill.
  - Be careful as the cut rivet will be very hot.
- (d) Remove the retainer from the bumper cover.

**19. REMOVE REAR BUMPER SIDE RETAINER RH****HINT:**

Use the same procedures described for the LH side.

**20. REMOVE REAR BUMPER SIDE MOUNTING BRACKET LH**

- (a) Remove the screw and bracket.

**21. REMOVE REAR BUMPER SIDE MOUNTING BRACKET RH**

- (a) Remove the screw and bracket.

**22. REMOVE REAR BUMPER ARM SUPPORT REINFORCE SUB-ASSY LH**

- (a) Remove the 2 bolts, nut and arm support.

**23. REMOVE REAR BUMPER ARM SUPPORT REINFORCE SUB-ASSY RH**

- (a) Remove the 2 bolts, nut and arm support.

**24. REMOVE REAR BUMPER RETAINER LOWER LH**

- (a) Remove the 3 screws and retainer lower.

**25. REMOVE REAR BUMPER RETAINER LOWER RH**

- (a) Remove the 3 screws and retainer lower.

**26. REMOVE ULTRASONIC SENSOR NO.1 (w/ CLEARANCE SONAR SYSTEM)**

- (a) Remove the 4 retainers and 4 sensors.

**27. REMOVE REAR BUMPER MOULDING****HINT:**

Remove the double-sided tape completely from the bumper. Double-sided tape interferes with the installation of the moulding to the bumper.

**28. REMOVE REAR BUMPER SIDE RETAINER NO.3 LH**

- (a) Remove the 2 clips and side retainer.

**29. REMOVE REAR BUMPER SIDE RETAINER NO.3 RH**

- (a) Remove the 2 clips and side retainer.

**30. INSTALL REAR BUMPER ARM SUPPORT REINFORCE SUB-ASSY LH**

- (a) Install the arm support with the 2 bolts and nut.

**Torque: 20 N·m (200 kgf·cm, 15 ft·lbf)**

**31. INSTALL REAR BUMPER ARM SUPPORT REINFORCE SUB-ASSY RH**

- (a) Install the arm support with the 2 bolts and nut.

**Torque: 20 N·m (200 kgf·cm, 15 ft·lbf)**

**32. INSTALL REAR BUMPER REINFORCEMENT SUB-ASSY**

- (a) Install the reinforcement with the 2 bolts and nut.

**Torque: 20 N·m (200 kgf·cm, 15 ft·lbf)**

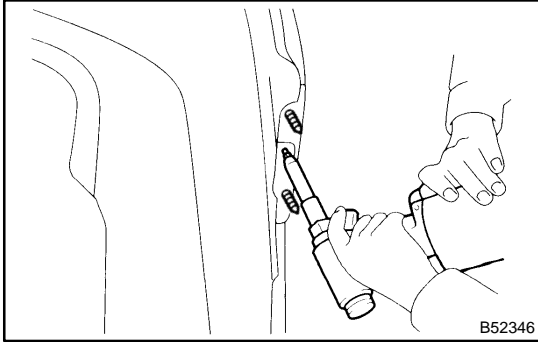
**33. INSTALL REAR BUMPER SIDE RETAINER LH**

- (a) Using an air riveter or hand riveter with nose piece, strike waterproof rivets of  $\phi$  4.9 mm (0.19 in.) into the side retainer to install the rivet to the bumper cover.

**NOTICE:**

**If the rivet is not positioned perpendicularly to the bumper, the mandrel will bend and become damaged.**

**34. INSTALL REAR BUMPER SIDE RETAINER RH****HINT:**

Use the same procedures described for the LH side.