

REMOVAL

1. REMOVE FRONT PILLAR GARNISH

- (a) Push the upper portion of front pillar garnish, then pull and release the clip.
- (b) Using a screwdriver, remove the front pillar garnish as shown in the illustration.

HINT:

Tape the screwdriver tip before use.

- (c) Employ the same manner described above to the other side.

NOTICE:

When install the front pillar garnish, replace new clip on the upper portion of front pillar garnish.

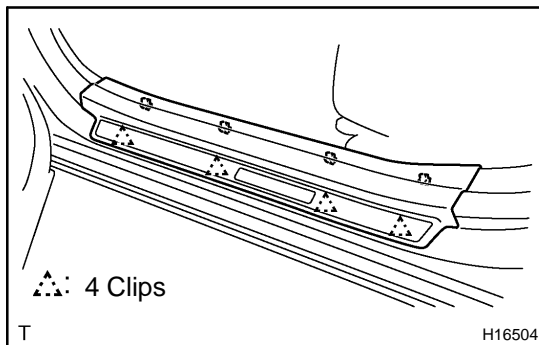

2. REMOVE FRONT DOOR SCUFF PLATE

- (a) Using a screwdriver, remove the front door scuff plate as shown in the illustration.

HINT:

Tape the screwdriver tip before use.

- (b) Employ the same manner described above to the other side.

3. REMOVE STEERING WHEEL PAD (See page [SR-15](#))

4. REMOVE STEERING WHEEL (See page [SR-15](#))

5. REMOVE UPPER AND LOWER COLUMN COVERS (See page [SR-15](#))

6. REMOVE COMBINATION SWITCH (See page [SR-15](#))

7. REMOVE SPIRAL CABLE (See page [SR-15](#))

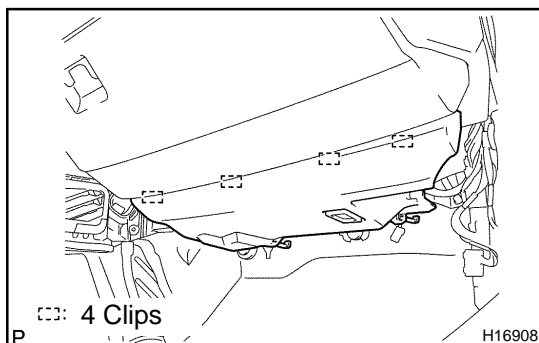

8. REMOVE NO. 2 UNDER COVER

Using a screwdriver, pry the No. 2 under cover to remove it.

HINT:

Tape the screwdriver tip before use.

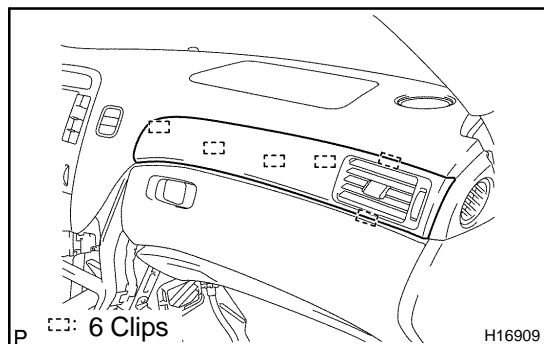
**9. REMOVE NO. 2 GARNISH**

Using a screwdriver, remove the No. 2 garnish.

HINT:

Tape the screwdriver tip before use.

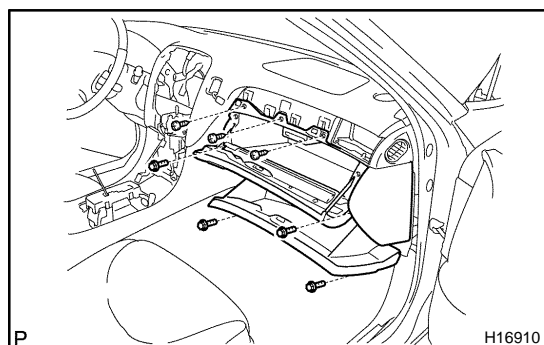
**10. REMOVE FINISH PANEL ASSEMBLY**

(a) Remove the 4 bolts and 3 screws.

(b) Using a screwdriver, remove the finish panel assembly.

HINT:

Tape the screwdriver tip before use.

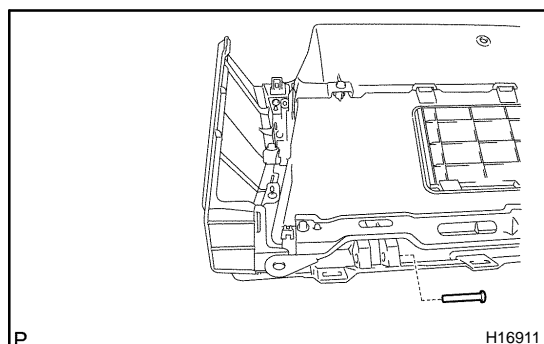
**11. REMOVE GLOVE COMPARTMENT DOOR**

(a) Remove the glove compartment door stopper.

(b) Employ the same manner described above to the other side.

(c) Remove the glove compartment door from the finish panel assembly.

(d) Remove the lower cover and 2 box plates from the finish panel assembly.

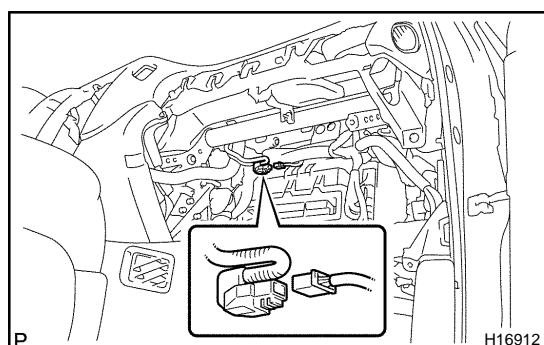
**12. DISCONNECT FRONT PASSENGER AIRBAG ASSEMBLY CONNECTOR**

Disconnect the front passenger airbag assembly connector as shown in the illustration.

NOTICE:

When handling the airbag connector, take care not to damage the airbag wire harness.

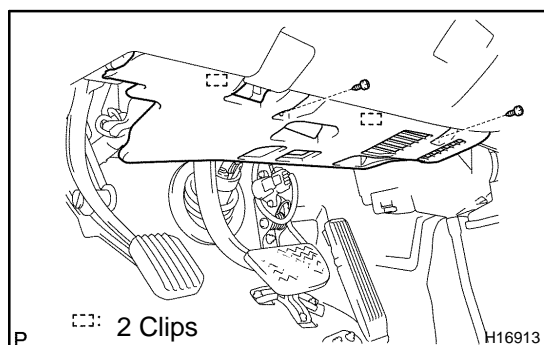
**13. REMOVE NO. 1 UNDER COVER**

(a) Remove the 2 screws.

(b) Using a screwdriver, remove the No. 1 under cover.

HINT:

Tape the screwdriver tip before use.

14. REMOVE NO. 1 SAFETY PAD

- (a) Remove the 2 screws and hood lock release lever.
- (b) Remove the 2 bolts and screw.

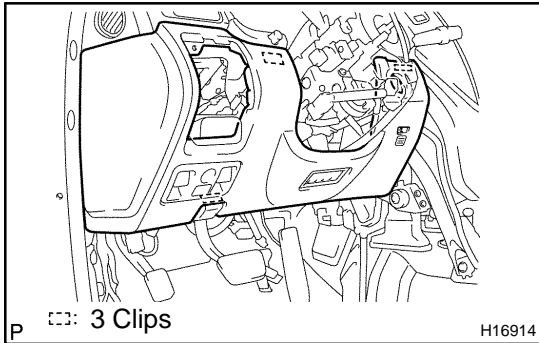

- (c) Using a screwdriver, remove the No. 1 safety pad.

HINT:

Tape the screwdriver tip before use.

- (d) Disconnect the connectors.

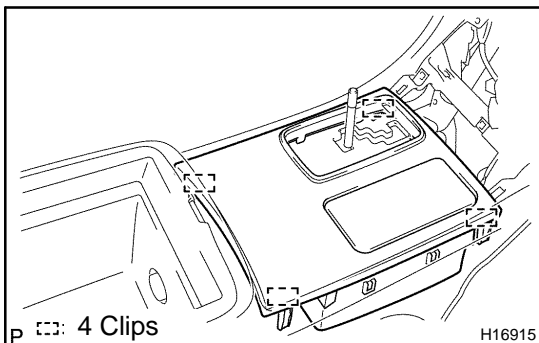
**15. REMOVE CLUSTER FINISH PANEL**

Using a screwdriver, remove the cluster finish panel.

HINT:

Tape the screwdriver tip before use.

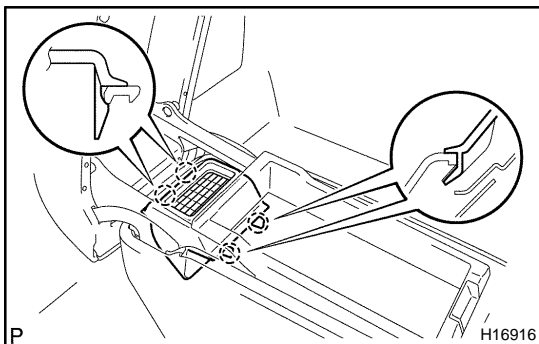
**16. REMOVE REAR CONSOLE ARMREST**

- (a) Using a screwdriver, remove the upper rear console panel.

HINT:

Tape the screwdriver tip before use.

- (b) Remove the console box carpet.

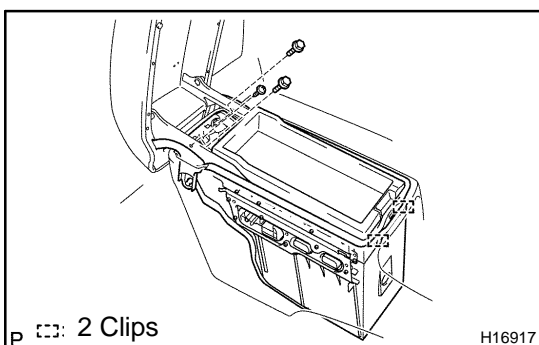

- (c) Remove the 2 bolts and screw.
- (d) Slide the inner tray and remove the 4 bolts.
- (e) Remove the rear console armrest.

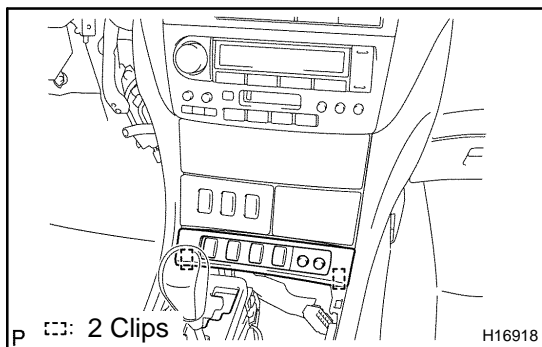
**17. REMOVE LOWER CENTER FINISH PANEL**

Using a screwdriver, remove the lower center finish panel.

HINT:

Tape the screwdriver tip before use.

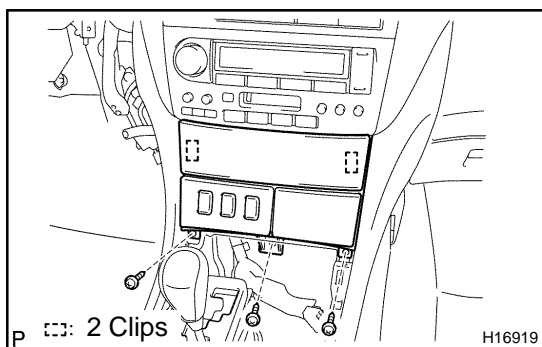
**18. REMOVE LOWER CLUSTER FINISH PANEL**

(a) Remove the 3 screws.

(b) Using a screwdriver, remove the lower cluster finish panel.

NOTICE:

Do not pull the door, when remove the lower cluster finish panel.

HINT:

Tape the screwdriver tip before use.

19. REMOVE AUDIO ASSEMBLY

Remove the 2 bolts and audio assembly, then disconnect the connector.

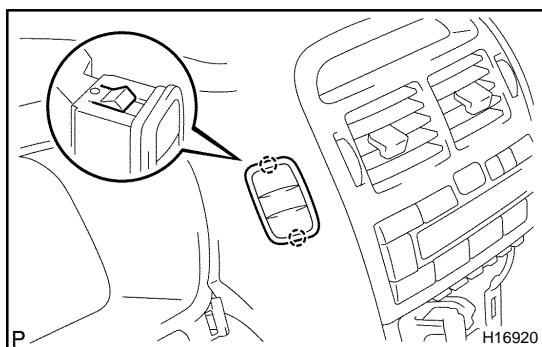
**20. REMOVE CENTER CLUSTER FINISH PANEL**

(a) Using a screwdriver, release the claws of the temperature control switch.

HINT:

Tape the screwdriver tip before use.

(b) Employ the same manner described above to the other side.

(c) Disconnect the connectors.

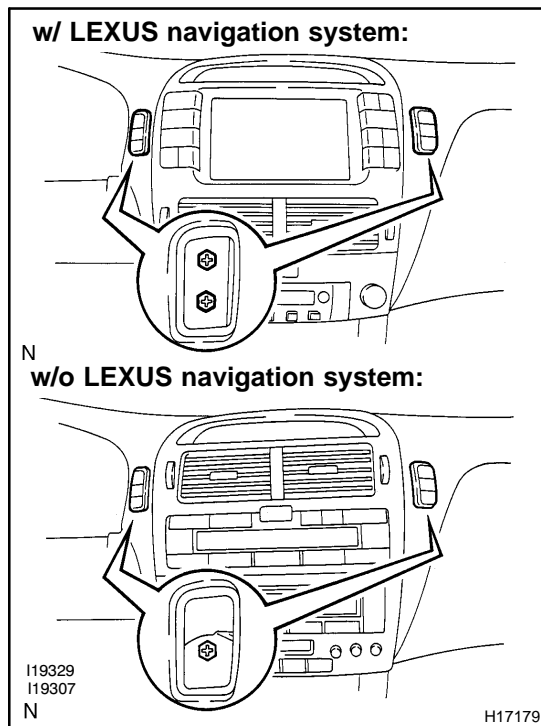

- (d) w/ LEXUS navigation system:
Remove the 4 bolts.
- (e) w/o LEXUS navigation system:
Remove the 2 bolts.
- (f) Using a screwdriver, remove the center cluster finish panel.

HINT:

- Tape the screwdriver tip before use.
- (g) Disconnect the connectors.

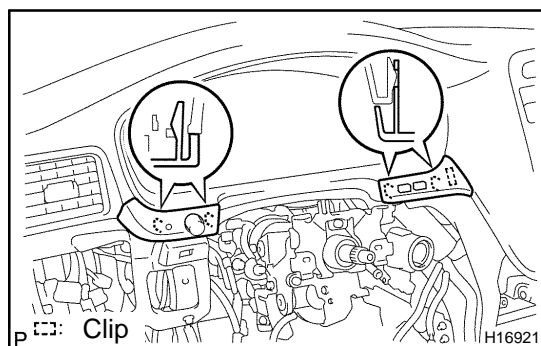
**21. REMOVE CLUSTER FINISH END PANEL**

- (a) Using a screwdriver, remove the cluster finish end panel.

HINT:

- Tape the screwdriver tip before use.
- (b) Disconnect the connector.

22. REMOVE CENTER LOWER CLUSTER FINISH PANEL

- (a) Using a screwdriver, remove the center lower cluster finish panel.

HINT:

- Tape the screwdriver tip before use.
- (b) Disconnect the connector.

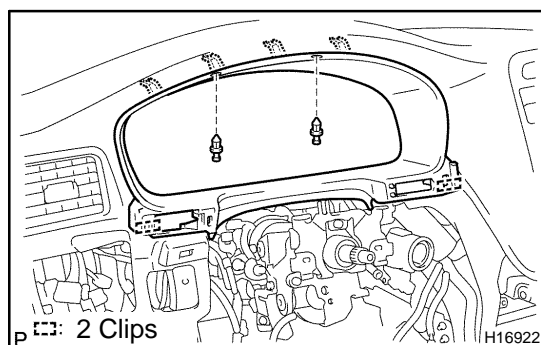
**23. REMOVE CLUSTER FINISH PANEL**

Remove the 2 clips and cluster finish panel.

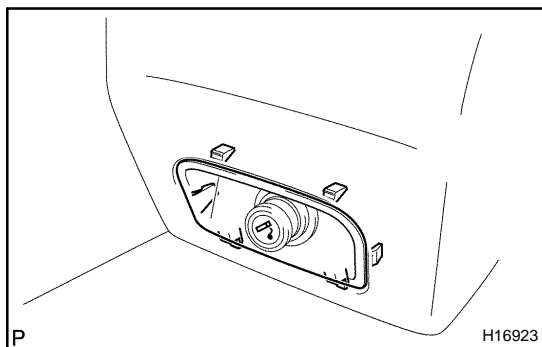
**24. REMOVE CONSOLE BOX**

(a) Using a screwdriver, remove the console box plate.

HINT:

Tape the screwdriver tip before use.

(b) Disconnect the connector.

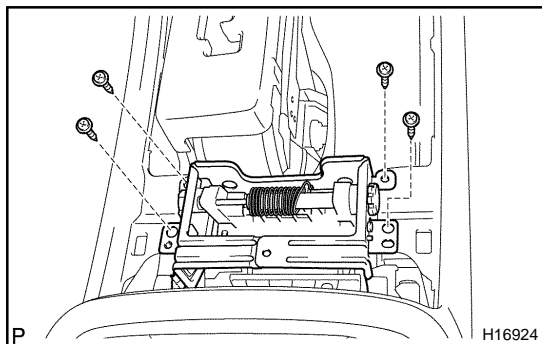

(c) Remove the 4 screws and cup holder.

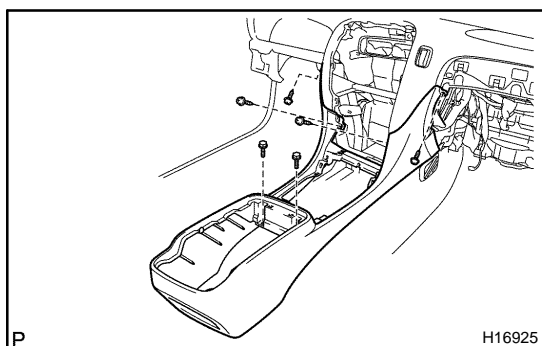

(d) Remove the 2 bolts, 4 screws and console box.

25. REMOVE COMBINATION METER

(a) Remove the 3 screws, then disconnect the connectors.

(b) Remove the combination meter.

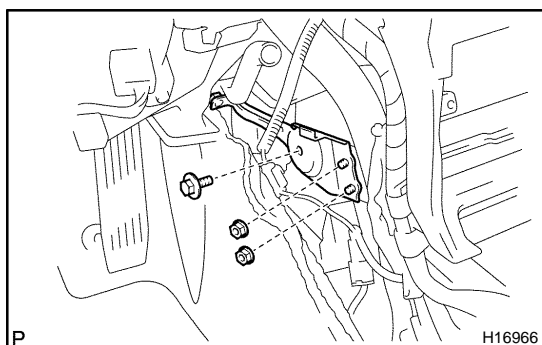
**26. REMOVE INSTRUMENT PANEL PLATE**

Remove the bolt, 2 nuts and instrument panel plate.

27. REMOVE SAFETY PAD WITH REINFORCEMENT

- (a) Disconnect the connectors.
- (b) Disengage the clamps.
- (c) Remove the 2 bolts, 4 nuts and disengage the safety pad from the reinforcement.

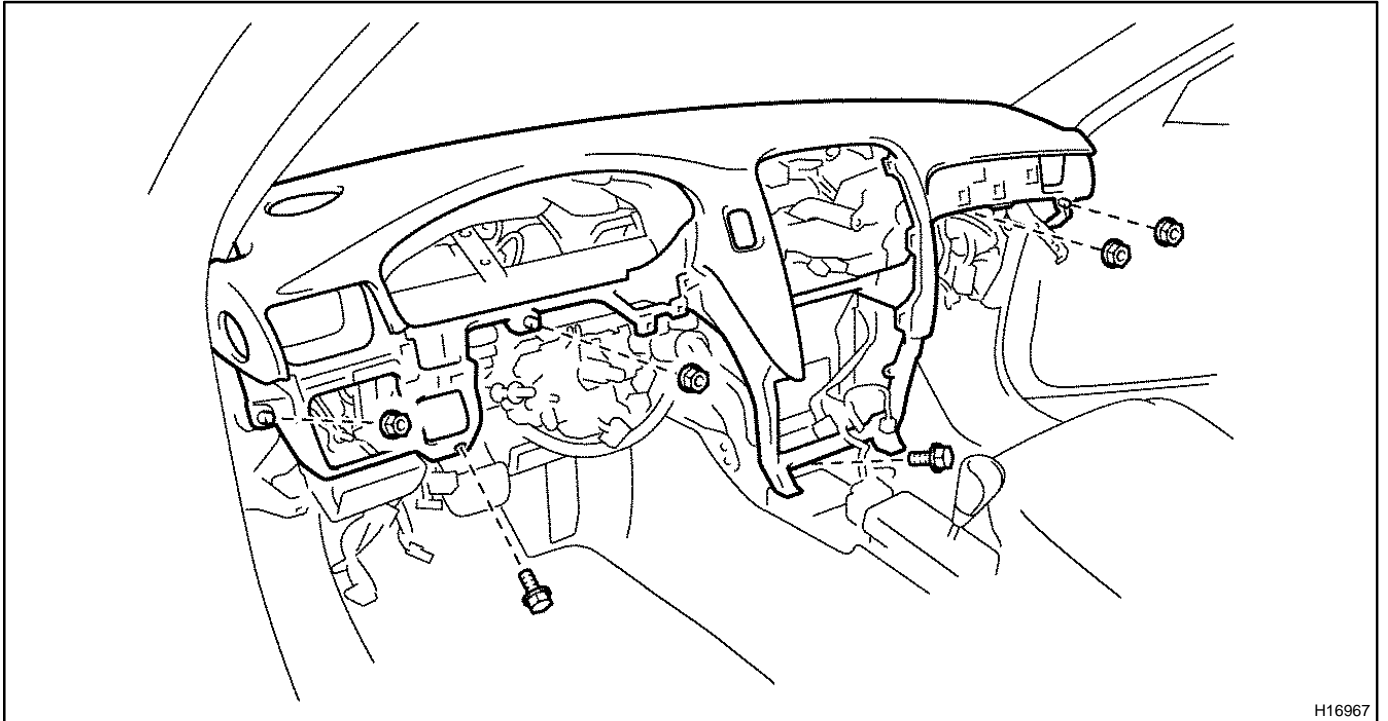

- (d) Remove the 8 bolts and loosen the bolt indicated by arrow shown in the illustration.
- (e) Remove the safety pad with reinforcement.

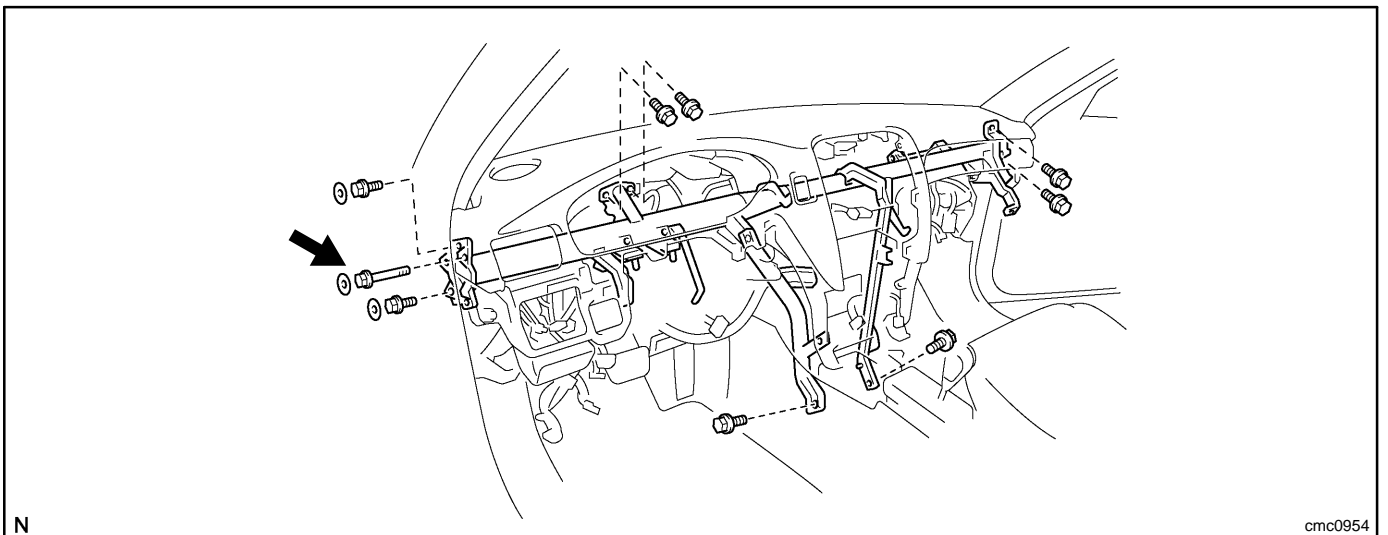

28. REMOVE REINFORCEMENT

- (a) Remove the 3 screws.
- (b) Remove the reinforcement from the safety pad.