

Be Sure To Ask Your Autosound Specialist About These Other Exciting SoundGate Products...

Simple-fi.™

- Competition-Grade Interfaces for adding amplifiers
- Remote audio control interfaces that let you control aftermarket receivers and CD players from your factory rear seat, or steering-wheel-mounted audio controls.
- And many others!

Why SoundGate Dealers have the edge...

The technologies used in today's vehicles are as sophisticated as any laptop computer. At SoundGate we believe these new technologies are full of opportunities for mobile electronic dealers across the nation. We make it a high priority to not only research these new systems, but to understand them and their impact on the aftermarket car audio industry. Armed with this knowledge, we are well equipped to help you integrate new components into these systems with our innovative, high-performance interfaces and unparalleled technical support.

Liability Disclaimer: SoundGate®, Stillwater Designs, Inc., its subsidiaries, or Officers of the corporation cannot be held liable for damages or injuries caused by, or resulting from the use of this instruction guide or product.

REPAIR OR REPLACEMENT IS THE EXCLUSIVE REMEDY OF THE PURCHASER. ANY IMPLIED WARRANTY ON THIS PRODUCT INCLUDING MERCHANTABILITY OR FITNESS FOR A PARTICULAR PURPOSE IS LIMITED IN DURATION TO THE DURATION OF THE WARRANTY (please see the enclosed Limited Warranty document for complete Warranty information). SOUNDGATE NEITHER ASSUMES NOR AUTHORIZES ANY OTHER PERSON TO ASSUME FOR IT ANY OTHER LIABILITY IN CONNECTION WITH THE SALE AND USE OF THIS PRODUCT. SOUNDGATE PROHIBITS ANY RETAILER FROM EXTENDING ANY WARRANTY OR WARRANTIES ON BEHALF OF SOUNDGATE TO ANY PERSON. SOUNDGATE IS NOT RESPONSIBLE FOR ANY INDIRECT, INCIDENTAL, OR CONSEQUENTIAL DAMAGES.

Strictly adhere to all car manufacturer warnings that pertain to the disassembly, maintenance, or servicing of the vehicle and any of its associated parts or systems.

SoundGate cannot be held responsible for discrepancies, or inconsistencies that may occur due to vehicle manufacturing changes.

If you feel that you cannot agree with the above limitations, please return this product to the dealer you purchased it from, or call SoundGate Customer service at 800-256-0808 for a Return Authorization number, and return the product to SoundGate for a credit or refund.

VIDTOY01V4



Purpose...

The VIDTOY01V4 allows you to add up to 2 video signals

(DVD, VCR, rearview camera, game console, etc.) to the factory navigation systems on the Toyota vehicles listed below.

Note: The VIDTOY01V4 provides video input only. To input audio signals, you will need an additional interface (sold separately - see below).

Features...

The VIDTOY01V4 utilizes microprocessor control, ultra-reliable surface-mount construction, and advanced firmware design, to flawlessly match the video signal from the new sources to the factory system.

The VIDTOY01V4 is also equipped with brightness, color and contrast adjustments to allow you to get the best quality picture possible.

The SoundGate VIDTOY01V4 works in the following navigation-equipped vehicles:

LEXUS

- 2001-08 RX300
- 2001-06 LS430*
- 2002-07 SC430

TOYOTA

- 2003-05 4Runner*
- 1998-08 Avalon*
- 2003-08 Highlander*
- 2003-08 Landcruiser*
- 2004-08 Prius*
- 2004-06 Sienna*

*without factory rearview camera

Simple-fi.™

Note:

Vehicle must have Navigation screen separate from radio (not integrated into the radio).

Audio input interfaces (required if you need to input audio signals also):

VIDFM8T or VIDFM40T - High-performance FM transmitter required for vehicles without factory remote-mounted CD changer

Copyright© 2004-2008 SoundGate®. All Rights Reserved. SoundGate® is a registered trademark of Stillwater Designs, Inc. All other trademarks are the property of their respective owners.

www.soundgate.com

Rev 20080520

If you experience any problems, call SoundGate Technical Support at 800-256-0808 or e-mail us at sgtech@soundgate.com.

VIDTOYO1V4 INSTALLATION INSTRUCTIONS

IMPORTANT WARNING!

It is illegal in all 50 U.S. states, and in most Canadian provinces, to have real time video (TV broadcast, VHS, DVD video, etc.) in view of the driver.

IF YOU ARE GOING TO USE THE SOUNDGATE VIDEO INTERFACE FOR ANYTHING OTHER THAN INTERFACING A REARVIEW CAMERA SYSTEM, THE BLUE INTERLOCK WIRE ON THE SOUNDGATE VIDEO MODULE MUST BE PROPERLY CONNECTED TO PREVENT THE DRIVER VIEWING REAL TIME VIDEO WHILE THE VEHICLE IS IN MOTION.

We do not want to put our dealers in a position of liability, nor our customers in danger in the event of an accident due to driver distraction.

If you do not intend to comply with applicable law, please return the SoundGate video module to the dealer it was purchased from, or to SoundGate if it was purchased direct. Call SoundGate Customer Service at 800-256-0808 for a Return Authorization.

Preliminary:

- A. Please consult a factory service manual for exact location and disassembly instructions if you are unsure of the procedure. Pay close attention to any warnings or instructions regarding working in or around airbags.
- B. Turn the ignition key to the "Off" position.
- C. Make sure the car's factory radio is turned to the "Off" position.

Step 1

Verify DIP switch settings on VIDTOYO1V4 module

On the end of the module as seen in the photo at lower left, you will see a red 5-position DIP switch. Verify that the switches are set as follows (On = **down**, Off = **up**):

2, 3 = on (down) 1, 4 and 5 = off (up)

Step 2

Install the video source unit(s)

Referencing the instructions provided with your video source units, install the components in the desired locations. Route the video cables and any required power, ground, and trigger wires to the factory radio location for connection to the VIDTOYO1V4.

Step 3

Disconnect factory navigation connector at radio

A. You will be connecting the SoundGate VIDTOYO1V4 at the factory navigation module (location shown below). Gain access to this location.

RX330/LS430	Under passenger seat
SC430	Behind passenger seat
4Runner	Right Rear Quarterpanel
Avalon	Driver side trunk
Highlander	Below radio
Landcruiser	Under passenger seat
Prius	Under driver seat
Sienna	Under rear passenger seat

STEP 3 CONTINUED...

- B. Disconnect the connector at the navigation unit (similar to male connector on VIDTOYO1V4 harness.

Step 4

Connect VIDTOYO1V4 harness to amplifier

- A. Plug the male connector on the VIDTOYO1V4 harness into the connector port vacated in Step 3 above.
- B. Plug the male connector disconnected in Step 3 above, into the white female connector on the VIDTOYO1V4 harness.
- C. Plug the white 16-pin Molex-style connector into the matching port on the VIDTOYO1V4.

Step 5

Connect remaining wires

Referencing Figure 1 and 2 below, connect the remaining wires on the VIDTOYO1V4 harness. One of the options shown will cover most installations.

Consult the documentation that came with your video component to determine which of these is appropriate for your installation.

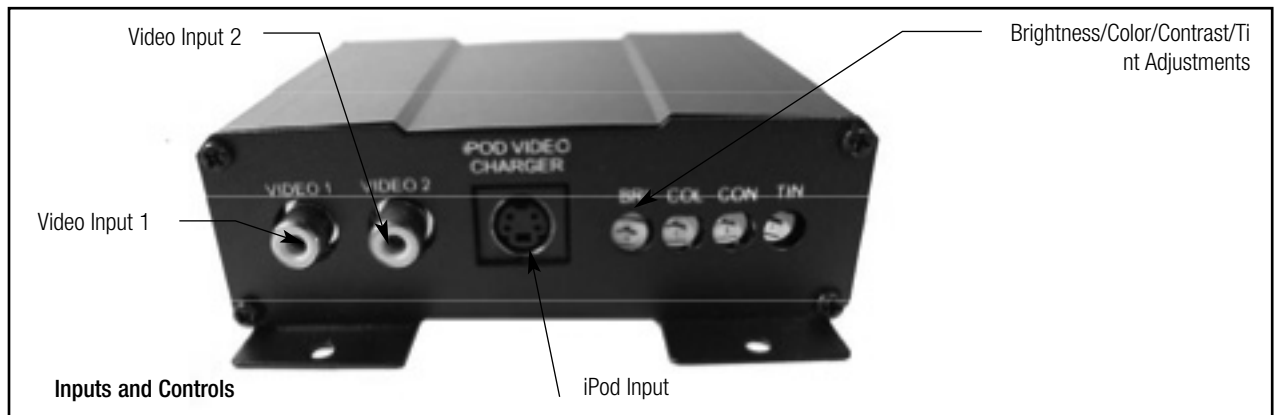
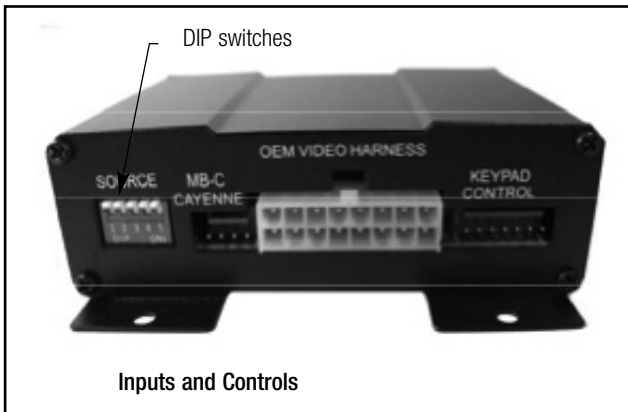

VIDTOYO1V4 INSTALLATION INSTRUCTIONS

Step 6

Reinstall radio and test operation

- A. If you have installed a rearview camera, start the vehicle, turn on the radio and navigation system and put the vehicle in reverse. The navigation display should change to show the view from the camera. Shifting the vehicle out of park should return you to the navigation display. If necessary, adjust the brightness, color and contrast with the controls on the VIDTOYO1V4.
- B. If you have installed a video system, with the vehicle in park gear, and the parking brake on, activate the video source. The navigation display will change to show the video source.
- C. With the video source active and playing, test the video interlock by taking off the parking brake. The navigation display should return.

Step 7

Finish installation

Once testing is done and the system is functioning properly, reinstall the all trim panels removed during installation. Installation is complete!

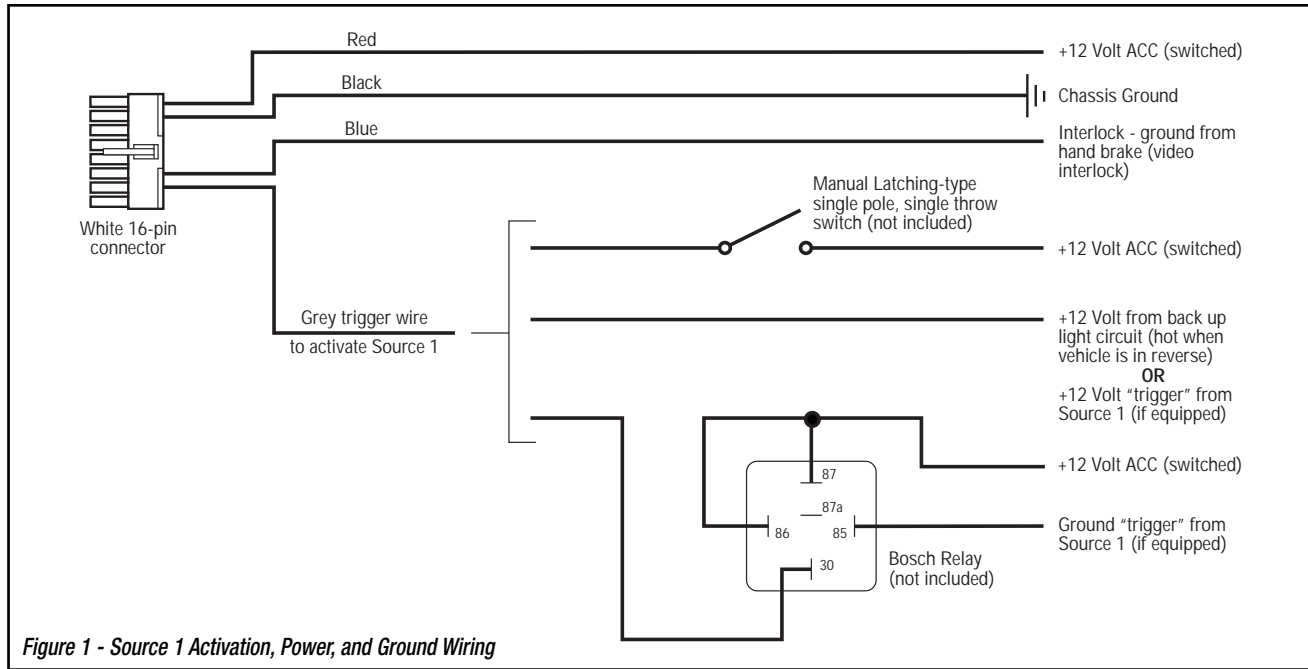

Figure 1 - Source 1 Activation, Power, and Ground Wiring

VIDTOYO1V4 OPERATION

Rearview camera: If you have installed a rearview camera system, and have the camera video signal connected to Video 1 with the grey Source 1 trigger wire fed from the back up light circuit, when you put the vehicle in reverse, the VIDTOYO1V4 will automatically switch the screen display to the rearview camera.

Adjusting picture quality: VIDTOYO1V4 module is equipped with brightness, color and contrast adjustments. **Note:** Adjustments affect both Video 1 and 2 equally (cannot be set individually).

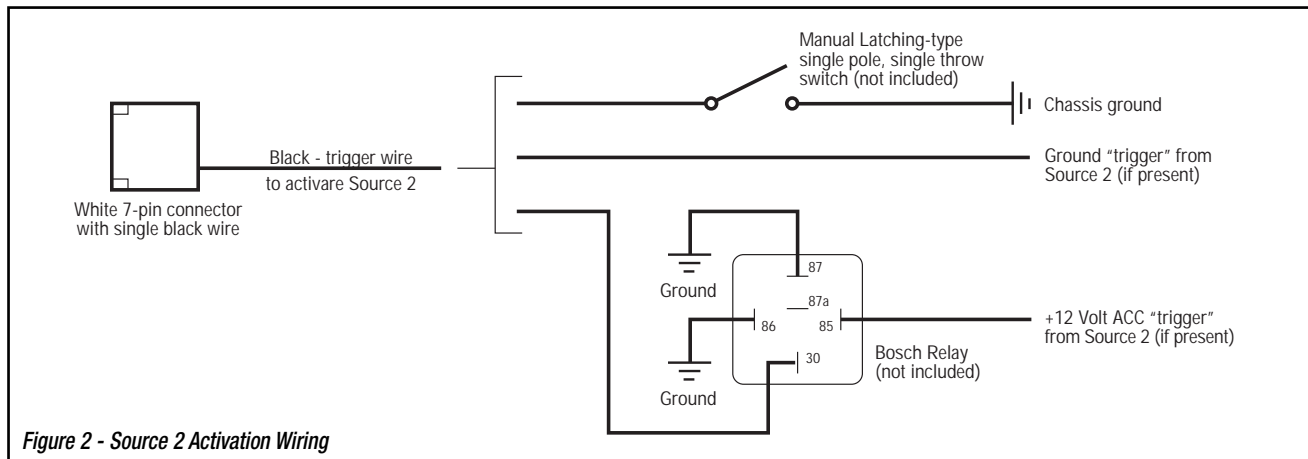

Figure 2 - Source 2 Activation Wiring