

D8BR-03

DTC	B1421/21	Solar Sensor Circuit (Passenger Side)
------------	-----------------	--

CIRCUIT DESCRIPTION

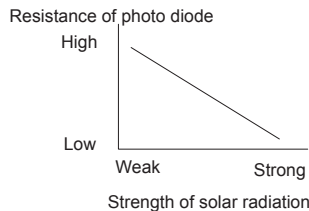

A photo diode in the solar sensor detects solar radiation and sends signals to the A/C ECU.

DTC No.	Detection Item	Trouble Area
B1421/21	Open or short in solar sensor circuit. Please note that display of diagnostic trouble code B1421/21 is not abnormal when the sensor is not receiving solar radiation.	<ul style="list-style-type: none"> • Solar sensor. • Harness or connector between solar sensor and A/C ECU. • A/C ECU.

WIRING DIAGRAM

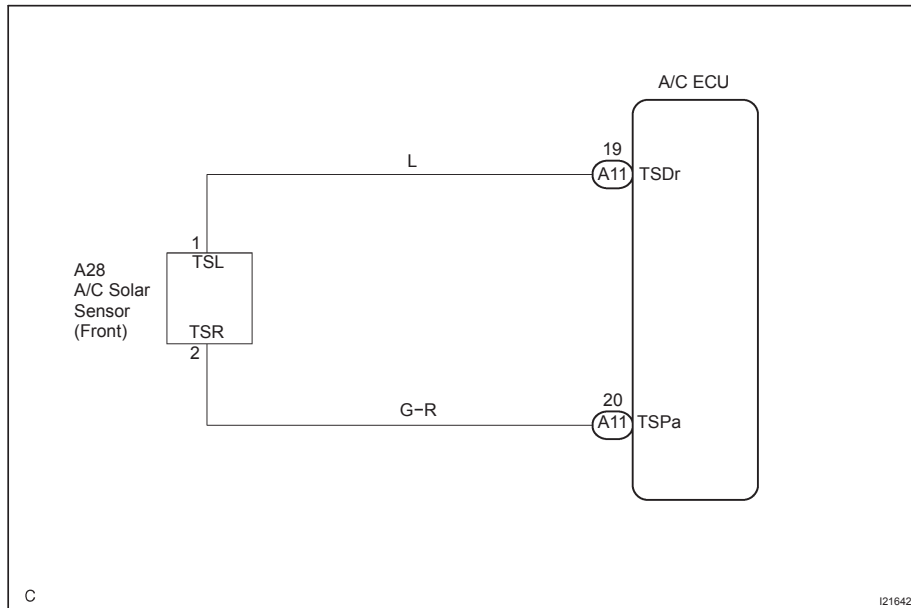

C

I21642

INSPECTION PROCEDURE

HINT:

In case of using the LEXUS hand-held tester, start the inspection step 1 and in case of not using the LEXUS hand-held tester, start from step 2.

1	Check solar sensor using LEXUS hand-held tester.
----------	---

PREPARATION:

Connect the LEXUS hand-held tester to the DLC3.

CHECK:

Check the solar sensor using DATA LIST.

OK
Check and replace A/C ECU.

NG

2	Check voltage between terminals TSPa and GND of A/C ECU connector.
----------	---

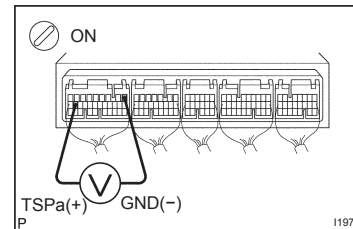

PREPARATION:

Remove A/C ECU with connectors still connected.

CHECK:

- (a) Turn ignition switch to ON.
- (b) Measure voltage between terminals TSPa and GND of A/C ECU connector when the solar sensor is subjected to an electric light, and when the sensor is covered with a cloth.

OK:

Condition	Voltage
Sensor subjected to electric light	0.8 - 4.3 V
Sensor covered by a cloth	Below 0.8 V

HINT:

As the inspection light is moved away from the sensor, the voltage increases.

NG
Go to step 3.

OK

Proceed to next circuit inspection shown on problem symptoms table (See page DI-1806). However, if DTC B1421/21 is displayed, check and replace A/C ECU.

3 Check wire harness

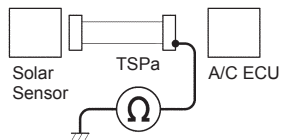

103347

PREPARATION:

Disconnect the connector of solar sensor and A/C ECU.

CHECK:

Check the continuity between wire harness and body ground.

OK:

Resistance: No continuity

NG

Repair or replace the wire harness.

OK

4 Check A/C ECU.

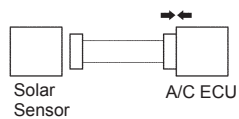

103348

PREPARATION:

Connect the connector of A/C ECU.

CHECK:

Check the DTC.

OK:

B1221/21 is not output.

NG

Replace the A/C ECU.

OK

Replace the solar sensor.