

D88V-03

<b>DTC</b>	<b>B1428/28</b>	<b>Solar Sensor Circuit (Rear Side)</b>
------------	-----------------	---

**CIRCUIT DESCRIPTION**

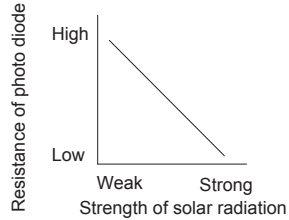

A photo diode in the solar detects solar radiation and sends signals to the A/C ECU.

DTC No.	Detection Item	Trouble Area
B1428/28	Open or short in solar sensor circuit. (Please note that display of DTC B1428/28 is not abnormal when the sensor is not receiving solar radiation.)	<ul style="list-style-type: none"> <li>• Solar sensor.</li> <li>• Harness or connector between solar sensor and A/C ECU.</li> <li>• A/C ECU.</li> </ul>

**WIRING DIAGRAM**

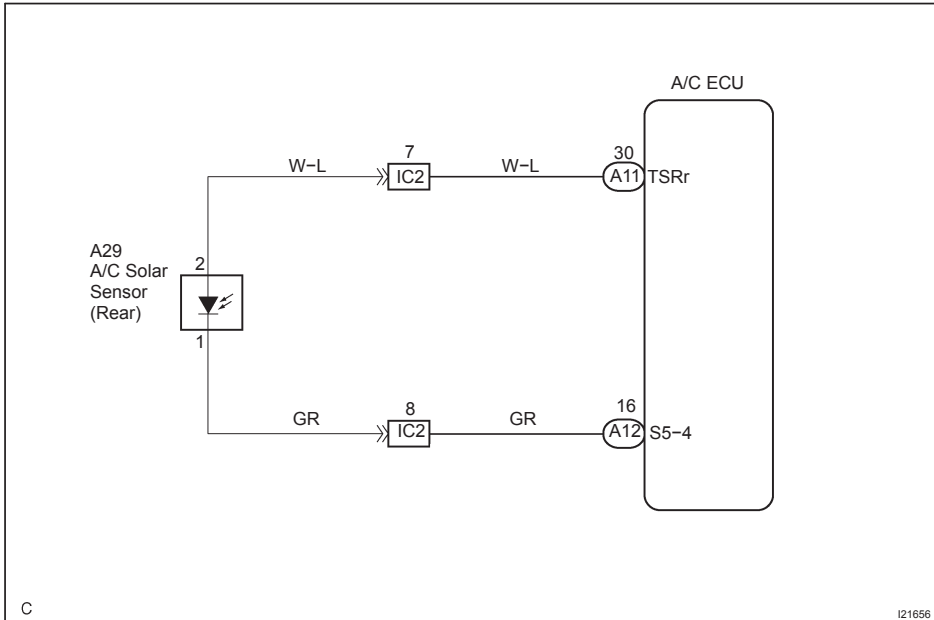

C

I21656

**INSPECTION PROCEDURE**

HINT:

In case of using the LEXUS hand-held tester, start the inspection step 1 and in case of not using the LEXUS hand-held tester, start from step 2.

<b>1</b>	<b>Check solar sensor using LEXUS hand-held tester.</b>
----------	---

**PREPARATION:**

Connect the LEXUS hand-held tester to the DLC3.

**CHECK:**

Check the solar sensor using DATA LIST.

OK
Check and replace A/C ECU.

NG

<b>2</b>	<b>Check voltage between terminals TSRr and S5-4 of A/C ECU connector.</b>
----------	--

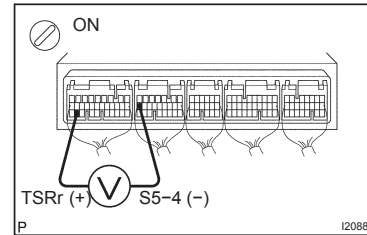

**PREPARATION:**

Remove A/C ECU with connectors still connected.

**CHECK:**

- (a) Turn ignition switch to ON.
- (b) Measure voltage between terminals TSRr and S5-4 of A/C ECU connector when the solar sensor is subjected to an electric light, and when the sensor is covered by a cloth.

**OK:**

Condition	Voltage
Sensor subjected to electric light	0.8 - 4.3 V
Sensor covered by a cloth	Below 0.8 V

HINT:

As the inspection light is moved away from the sensor, the voltage increases.

NG
Go to step 3.

OK

Proceed to next circuit inspection shown on problem symptoms table (See page DI-1806). However, if DTC B1428/28 is displayed, check and replace A/C ECU.

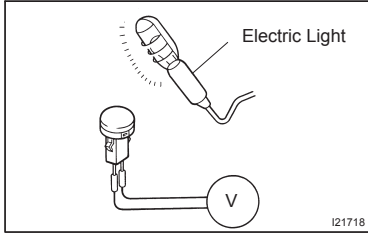
**3 Check solar sensor.****PREPARATION:**

Remove solar sensor.

**CHECK:**

- (a) Cover the sensor with a cloth.
- (b) Measure voltage between terminals 1 and 2 of solar sensor connector.

**HINT:**

Connect positive (+) lead of ohmmeter to terminal 1 and negative (-) lead to terminal 2 of the solar sensor.

**OK:**

**Voltage: Below 1.0 V**

**PREPARATION:**

- (a) Remove the cloth from the solar sensor and subject the sensor to electric light.
- (b) Measure voltage.

**OK:**

**Voltage: Approx. 0.4 V**

**HINT:**

As the electric light is moved away from the sensor, the voltage increases.

**NG****Replace solar sensor.****OK****4 Check harness and connector between A/C ECU and solar sensor (See page IN-34).****NG****Repair or replace harness or connector.****OK****Check and replace A/C ECU.**