

**BRAKE > BRAKE SYSTEM > PRECAUTION****CAUTION:**

- While the battery is connected, even if the engine switch is off, the brake control system activates when the brake pedal is depressed or the door courtesy switch turns on. Therefore during servicing of the brake system components, do not operate the brake pedal and open/close the doors while the battery is connected.
- The Techstream must be used when bleeding air. If not used, the air bleeding will be incomplete, which is hazardous and may lead to an accident.

**NOTICE:****for BRAKE SYSTEM**

- When adjusting the brake fluid level, turn the engine switch on (IG) and then add fluid until the fluid level is at the MAX line.
- Care must be taken to replace each part properly as it could affect the performance of the brake system and result in a driving hazard. Replace the parts with those having the same part number or equivalent.
- It is very important to keep parts and the work area clean when repairing the brake system.
- If the vehicle is equipped with a mobile communication system, refer to the precaution in the INTRODUCTION section (Refer to [INTRODUCTION > REPAIR INSTRUCTION > PRECAUTION\(200909 - \)](#)).
- Care must be taken when using magnets as they could affect the performance of the speed sensors.
- Since the brake line is classified as one of the critical safety related parts, be sure to disassemble the components if a brake fluid leak is found. If any abnormality is found, replace the component with a new one.
- When removing brake components, cover the brake tube connections to prevent foreign matter such as dust or dirt from entering the tubes.
- Do not damage or deform the brake tubes when removing or installing them.
- When installing a brake tube or flexible hose, ensure that they are free from twisting or bending.
- If the cap of the flexible hose does not match the groove on the bracket, twist the hose slightly to insert it.
- Flexible hoses must be free from absorber oil, grease, etc.
- When installing a brake tube to a plastic clamp, ensure that the brake tube is not loose or being pinched.
- Do not reuse a clip or plastic clamp removed from a flexible hose.
- After installing a brake tube and flexible hose, ensure that they do not interfere with any other components.
- Do not allow brake fluid to adhere to any painted surface such as the vehicle body. If brake fluid leaks onto any painted surface, immediately clean it off.
  
- Follow these procedures when disconnecting the flexible hose and brake tube.
  1. Hold the flexible hose with a wrench. Using a union nut wrench, disconnect the brake tube without deforming the tube.
  2. Remove the clip.
- Follow these procedures when connecting the flexible hose and brake tube.
  1. Install a new clip.

2. Hold the flexible hose with a wrench. Using a union nut wrench, connect the brake tube without deforming the tube.

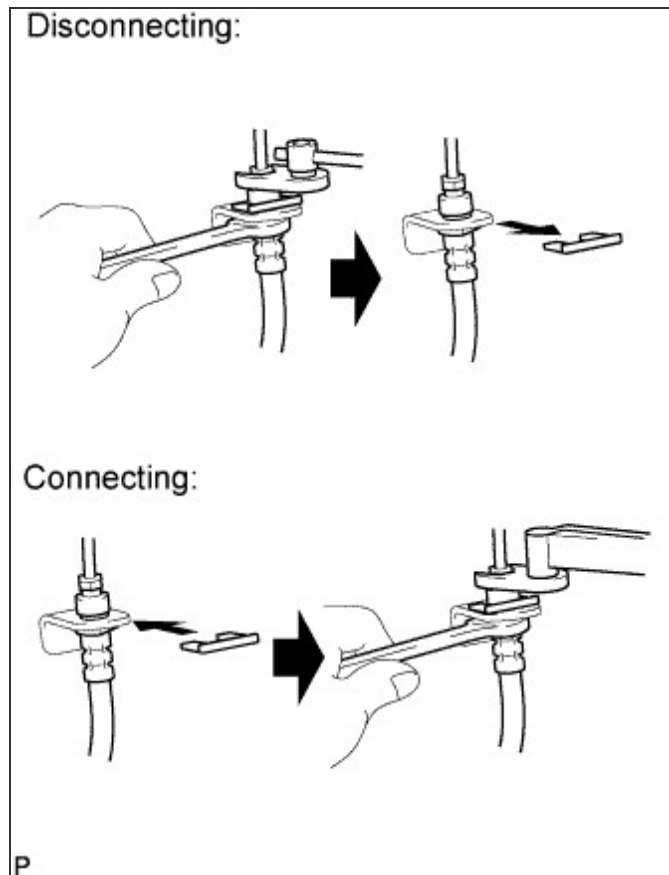

- Connect the brake tube and 2-way:
  1. Support the 2-way to prevent deformation of the brake tube and connect the brake tube to the 2-way with a union nut wrench.
  2. Support the 2-way to prevent deformation of the brake tube and install the bolt to fix the 2-way to the body.

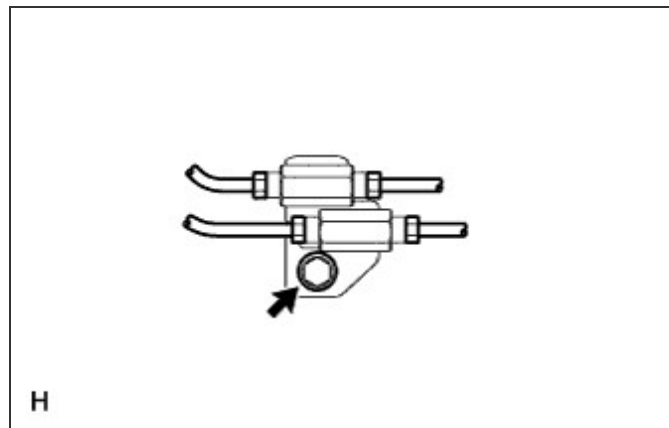

**NOTICE:**  
**for BLEEDING:**

- Refer to the Techstream operator's manual for further details.
- Move the shift lever to the P position and apply the parking brake before bleeding the brakes.
- Add brake fluid to keep the level between MIN and MAX lines of the reservoir while bleeding the brakes.
- As brake fluid may overflow when bleeding air, do not place the fluid can on the reservoir filler opening.
- If the brake accumulator pump operates while air remains inside the No. 2 brake actuator hose, air will enter the brake accumulator pump, resulting in difficulty in bleeding. Keep the 2 brake accumulator pump connectors disconnected before bleeding.
- The brake accumulator pump and brake actuator solenoid can be operated by the driver even if the engine switch is off.

- Although a buzzer may sound due to declined accumulator pressure during bleeding, continue bleeding.
- If DTCs indicating a malfunction in the ABS motor relay or pressure sensor are stored after bleeding, clear the DTCs after bleeding.

**HINT:**

- Air bleeding with the Techstream cannot be performed when the engine switch is on (IG) or when the parking brake is not operating (electric parking brake operation signal is not input into skid control ECU).
- While performing air bleeding, a display and navigation assembly (with HDD navigation system) or multi-display (without HDD navigation system) malfunction warning is displayed. However, there is no malfunction. After performing air bleeding, erase the warning using the screen's menus.