

Last Modified: 12-7-2021	6.10:8.0.50	Doc ID: RM0000011MI04VX
Model Year Start: 2011	Model: LS460	Prod Date Range: [09/2010 -]
Title: LIGHTING: HEADLIGHT ASSEMBLY: ADJUSTMENT; 2011 MY LS460 [09/2010 -]		

ADJUSTMENT

HINT:

It is possible that a bulb is incorrectly installed, affecting headlight aim. Bulb installation should be considered prior to performing the adjustment procedure.

1. CHECK HEADLIGHT

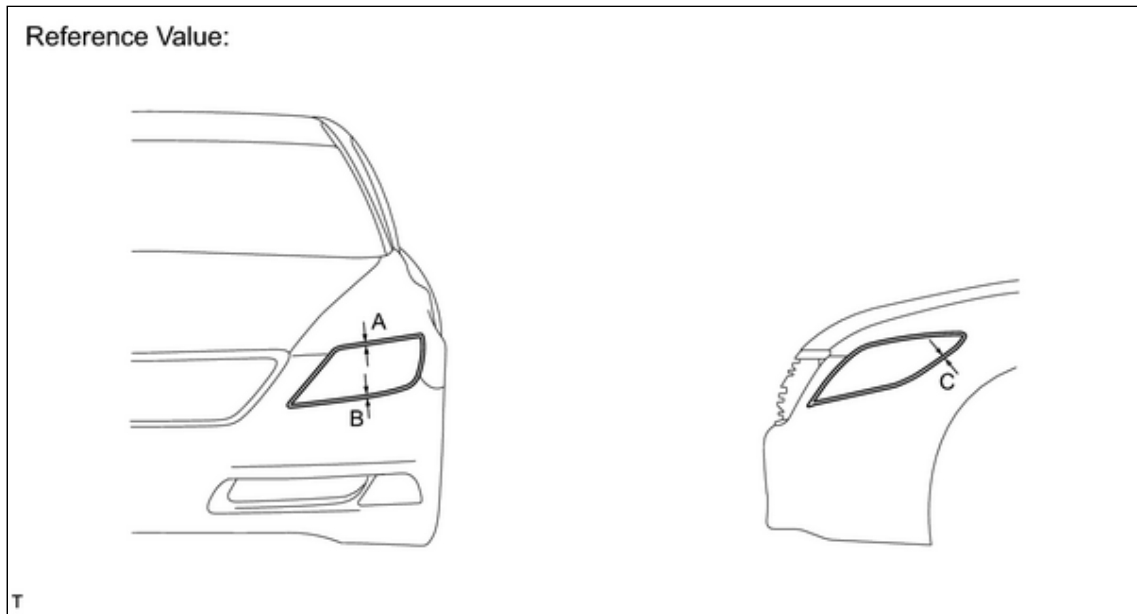

(a) Check that each measurement is within its respective reference value.

Reference value

A	1.3 +/-0.8 mm (0.051 +/-0.031 in.)
B	1.6 +/-1.5 mm (0.063 +/-0.059 in.)
C	1.3 +/-0.8 mm (0.051 +/-0.031 in.)

2. REMOVE ENGINE ROOM SIDE COVER LH

3. REMOVE ENGINE ROOM SIDE COVER

4. REMOVE AIR CLEANER INLET COVER SUB-ASSEMBLY

5. REMOVE COOL AIR INTAKE DUCT SEAL

6. ADJUST HEADLIGHT

(a) Adjust the headlight fitting.

(1) Using a screwdriver, adjust the headlight vertically as shown in the illustration.

HINT:

To adjust the headlight downward, turn the adjusting screw clockwise. To adjust the headlight upward, turn the adjusting screw counterclockwise.

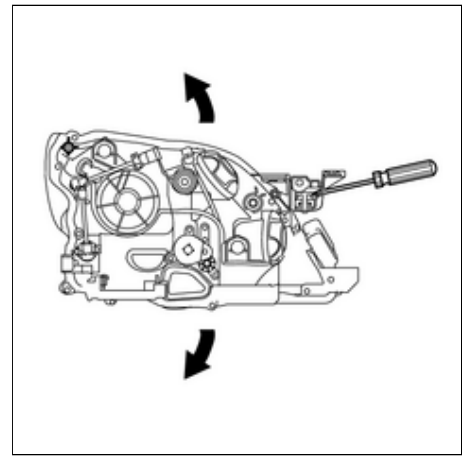

7. INSTALL COOL AIR INTAKE DUCT SEAL

8. INSTALL AIR CLEANER INLET COVER SUB-ASSEMBLY

9. INSTALL ENGINE ROOM SIDE COVER

10. INSTALL ENGINE ROOM SIDE COVER LH

11. VEHICLE PREPARATION FOR HEADLIGHT AIMING ADJUSTMENT

(a) Prepare the vehicle:

- Ensure there is no damage or deformation to the body around the headlights.
- Fill the fuel tank.
- Make sure that the oil is filled to the specified level.
- Make sure that the coolant is filled to the specified level.
- Inflate the tires to the appropriate pressure.
- Unload the trunk and vehicle, ensuring that the spare tire, tools, and jack are also removed.
- Have a person of average weight (68 kg, 150 lb) sit in the driver's seat.
- Vehicles with an adjustable suspension should be set to the lowest vehicle height prior to adjusting the headlight aim.
- Vehicles with manually adjustable headlights should be adjusted to "0".

12. PREPARATION FOR HEADLIGHT AIMING (Using a screen)

(a) Prepare the vehicle:

- Place the vehicle in a location that is dark enough to clearly observe the cutoff line. The cutoff line is a distinct line, below which light from the headlights can be observed and above which it cannot.
- Place the vehicle at a 90° angle to the wall.
- Create a 7.62 m (25.0 ft.) distance between the vehicle (headlight bulb center) and the wall.
- Make sure that the vehicle is on a level surface.
- Bounce the vehicle up and down to settle the suspension.

NOTICE:

A distance of 7.62 m (25.0 ft.) between the vehicle (headlight bulb center) and the wall is necessary for proper aim adjustment. If sufficient space is not available, secure a distance of exactly 3 m (9.84 ft.) to allow for checking and adjustment of headlight aim. (The size of the target zone will change with the distance, so follow the instructions in the illustration.)

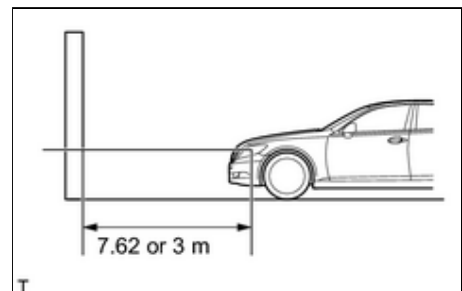

- (b) Prepare a piece of thick white paper (approximately 2 m (6.56 ft.) (height) x 4 m (13.1 ft.) (width)) to use as a screen.
- (c) Draw a vertical line down the center of the screen (V line).
- (d) Set the screen as shown in the illustration.

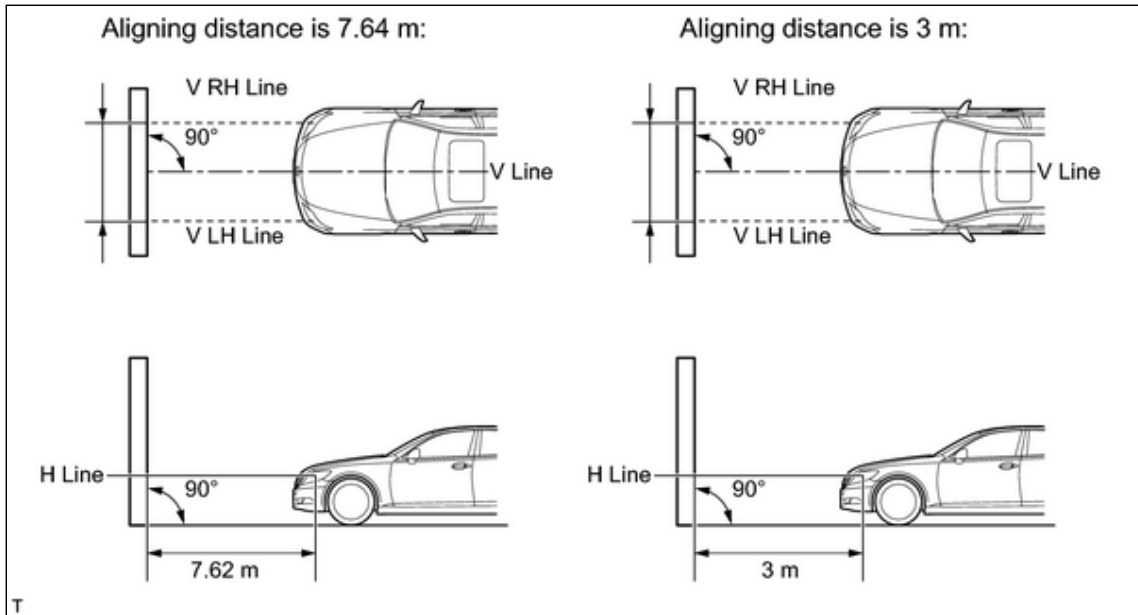

HINT:

- Stand the screen perpendicular to the ground.
- Align the V line on the screen with the center of the vehicle.

- (e) Draw base lines (H, V LH, and V RH lines) on the screen as shown in the illustration.

HINT:

- The base lines differ for "low-beam inspection" and "high-beam inspection."
- Mark the headlight bulb center marks on the screen. If the center mark cannot be observed on the headlight, use the center of the headlight bulb or the manufacturer's name marked on the headlight as the center mark.

- (1) H Line (Headlight height):

Draw a horizontal line across the screen so that it passes through the center marks. The H line should be at the same height as the headlight bulb center marks of the low-beam headlights.

- (2) V LH Line, V RH Line (Center mark position of left-hand (LH) and right-hand (RH) headlights):

Draw two vertical lines so that they intersect the H line at each center mark (aligned with the center of the low-beam headlight bulbs).

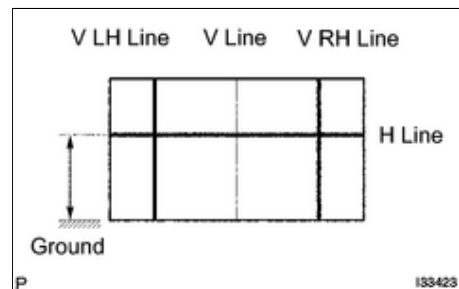

13. HEADLIGHT AIMING INSPECTION

- (a) Cover the headlight or disconnect the connector of the headlight on the opposite side to prevent light from the headlight that is not being inspected from affecting the headlight aiming inspection.

NOTICE:

Do not keep the headlight covered for more than 3 minutes. The headlight lens is made of synthetic resin, which may melt or be damaged due to excessive heat.

HINT:

When checking the aim of the high-beam, cover the low-beam or disconnect the connector.

- (b) Start the engine.

(c) Turn on the headlight and check if the cutoff line matches the preferred cutoff line in the following illustration.

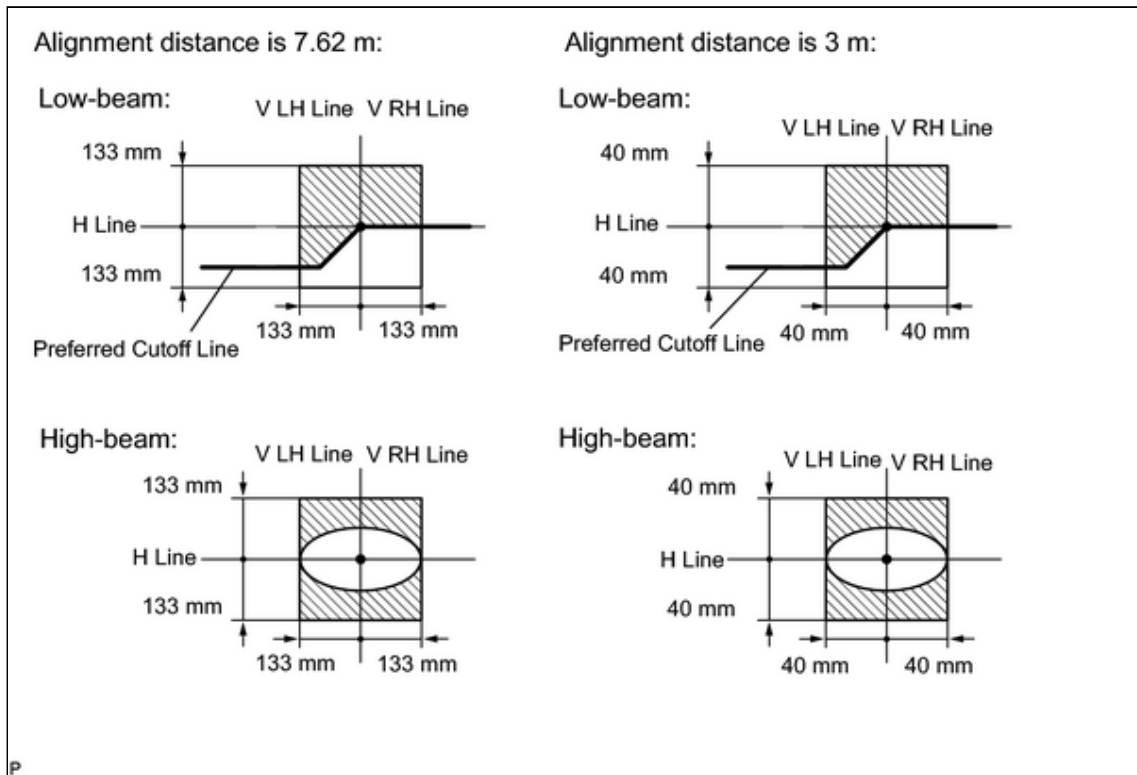

HINT:

- Since the low beam light and the high beam light on each side have separate reflectors, it is necessary to check and adjust the aim separately for both.
- If the alignment distance is 7.62 m (25.0 ft.):
 - The cutoff line should be within 133 mm (5.24 in.) above or below the H line as well as 101.6 mm (3.99 in.) left or right of the V line with low-beam.
- If the alignment distance is 3 m (9.84 ft.):
 - The low beam cutoff line should be within 40 mm (1.57 in.) above or below the H line as well as 40 mm (1.57 in.) left or right of the V line.
- If the alignment distance is 7.62 m (25.0 ft.):
 - The high beam center of intensity should be within 133 mm (5.24 in.) above or below the H line as well as 101.6 mm (3.99 in.) left or right of the V line.
- If the alignment distance is 3 m (9.84 ft.):
 - The high beam center of intensity should be within 40 mm (1.57 in.) above or below the H line as well as 40 mm (1.57 in.) left or right of the V line.
- If the alignment distance is 7.62 m (25.0 ft.):
 - The low beam cutoff line should be 87 mm (3.43 in.) below the H line (preferred cutoff line target).
- If the alignment distance is 3 m (9.84 ft.):
 - The low beam cutoff line should be 26 mm (1.02 in.) below the H line (preferred cutoff line target).

14. HEADLIGHT AIMING ADJUSTMENT

(a) Adjust the aim vertically:

Adjust the aim of each headlight to the specified range by turning each aiming screw with a screwdriver.

NOTICE:

The final turn of the aiming screw should be made in the clockwise direction. If the screw is tightened excessively, loosen it and then retighten it, so that the final turn of the screw is in the clockwise direction.

HINT:

- The low-beam light and the high-beam light are a unit. Adjusting the aim on the low-beam to the correct position should also result in the high-beam adjustment being correct.
- If it is not possible to correctly adjust headlight aim, check bulb, headlight unit, and headlight unit reflector installation.
- The headlight aim moves up when turning the aiming screw clockwise, and moves down when turning the aiming screw counterclockwise.

