



**Technical Service
Information Bulletin**

September 1, 2005

Title:

EXHAUST BOOMING AT IDLE

Models:

'98 – '06 LX 470

ENGINE
EG012-05

TSIB UPDATE NOTICE:

The information contained in this TSIB supercedes TSIB No. EG001-04. TSIB No. EG001-04 is now obsolete and should be discarded.

Introduction Some 1998 – 2006 model year LX 470 vehicles may exhibit an exhaust booming noise after the vehicle reaches operating temperature at idle with the vehicle stopped and the transmission in the “D” range. The following procedures have been developed to correct this condition.

Applicable Vehicles

- 1998 – 2006 model year LX 470 vehicles produced in the VIN ranges listed below.

MODEL	MODEL YEAR	APPLICABLE VEHICLE VIN RANGE
LX 470	1998 – 1999	JT6HT00W#W0001038 – JT6HT00W#X0034463
	1999 – 2003	JT6HT00W#X0034464 – JTJHT00W#33531227
	2003	JTJHT00W#33531228 – JTJHT00W#33535395
	2003 – 2005	JTJHT00W#33535396 – JTJHT00W#53548997
	2005 – 2006	JTJHT00W#53548998 – JTJHT00W#64003452
	2006	JTJHT00W#64003453 – End of 2006 MY Production

Required Tools & Material

TOOLS & MATERIAL	QUANTITY
Metric Hand Tools / Wrenches / Sockets	As Necessary

Warranty Information

OP CODE	DESCRIPTION	TIME	OFF	T1	T2
EG4001	Install Revised Parts for Specific Model Year and VIN Range as Indicated by the Supplied Parts Information in this TSIB	2.5	12361-50210	91	99

Applicable Warranty*:

This repair is covered under the Lexus Powertrain Warranty. This warranty is in effect for 72 months or 70,000 miles, whichever occurs first, from the vehicle's in-service date.

* Warranty application is limited to correction of a problem based upon a customer's specific complaint.



Parts
Information

REPAIR PROCEDURE	PREVIOUS PART NUMBER	CURRENT PART NUMBER	PART NAME	QTY	
A	17405–50030	17405–50040	Pipe Assembly, Exhaust, Tail	1	
B	90179–10070	Same	Nut, Exhaust Pipe Set Stud Bolt	6	
	94185–61000	90177–A0004	Nut, Lock	6	
C1	N/A	N/A	Wire (Size: 100 cm, 3 sq)*	3	
	51543–60020	Same	Bracket, Damper	1	
C2	51259–60030	Same	Weight, No. 4 Crossmember Damper	1	
	91626–61030	Same	Bolt, w/Washer	2	
D	N/A (no parts needed)				
E1	E2	17581–70090	Same	Damper, Exhaust Pipe (32 Hz)	1
		17581–50090	Same	Damper, Exhaust Pipe (39 Hz)	1
		17581–17020	Same	Damper, Exhaust Pipe (48 Hz)	1
		17581–50140	Same	Damper, Exhaust Pipe (43.8 Hz)	1
		17581–70080	Same	Damper, Exhaust Pipe (34.6 Hz)	1
	17551–50090	17551–50091	Insulator, Exhaust Pipe Heat, No. 1	1	
F	51259–60030	51259–60040	Weight, No. 4 Crossmember Damper	1	
	91626–61030	Same	Bolt, w/Washer	2	
G	12371–50180	Same	Insulator, Engine Mounting, RR	1	
H	12361–50210	Same	Insulator, Engine Mounting, FR	2	

* Prepare the wires at the dealer.

Repair
Procedure
Order

Using the model years and VIN ranges provided in the chart below, locate the model year and VIN of the complaint vehicle. Determine the parts that will be necessary to install **AND** in what order to perform the installation operation.

MODEL YEAR	APPLICABLE VEHICLE VIN RANGE	REPAIR PROCEDURE REPLACEMENT ORDER**
1998 – 1999	JT6HT00W#W0001038 – JT6HT00W#X0034463	A, B, C1, D, E1, F
1999 – 2003	JT6HT00W#X0034464 – JTJHT00W#33531227	A, B, C1, D, E1, F, G, H
2003	JTJHT00W#33531228 – JTJHT00W#33535395	A, B, C1, D, E1, F, H
2003 – 2005	JTJHT00W#33535396 – JTJHT00W#53548997	A, B, C2, D, E1, F, H
2005 – 2006	JTJHT00W#53548998 – JTJHT00W#64003452	A, B, C2, D, E2, F, H
2006	JTJHT00W#64003453 – End of 2006 MY Production	B, C2, D, E2, F, H

** Refer to Parts Information.

Use the following repair procedures to install the necessary parts. Be sure to install the parts using the installation order provided in the above chart.

Repair
Procedure A**Install New Tailpipe Assembly**

- Refer to the Technical Information System (TIS), applicable model year LX 470 Repair Manual: *Engine Mechanical:Exhaust System:Components*.

Repair Procedure B

Retighten Exhaust Pipe and Readjust Exhaust Pipe Support Clearance

1. Temporarily loosen all of the exhaust system flange bolts.
2. Retighten the flange bolts to the specified torque in order starting with the front exhaust pipe flange (from 1 to 6).

NOTE:

The 12 nuts indicated in the boxes below are NOT reusable and must be replaced with new parts.

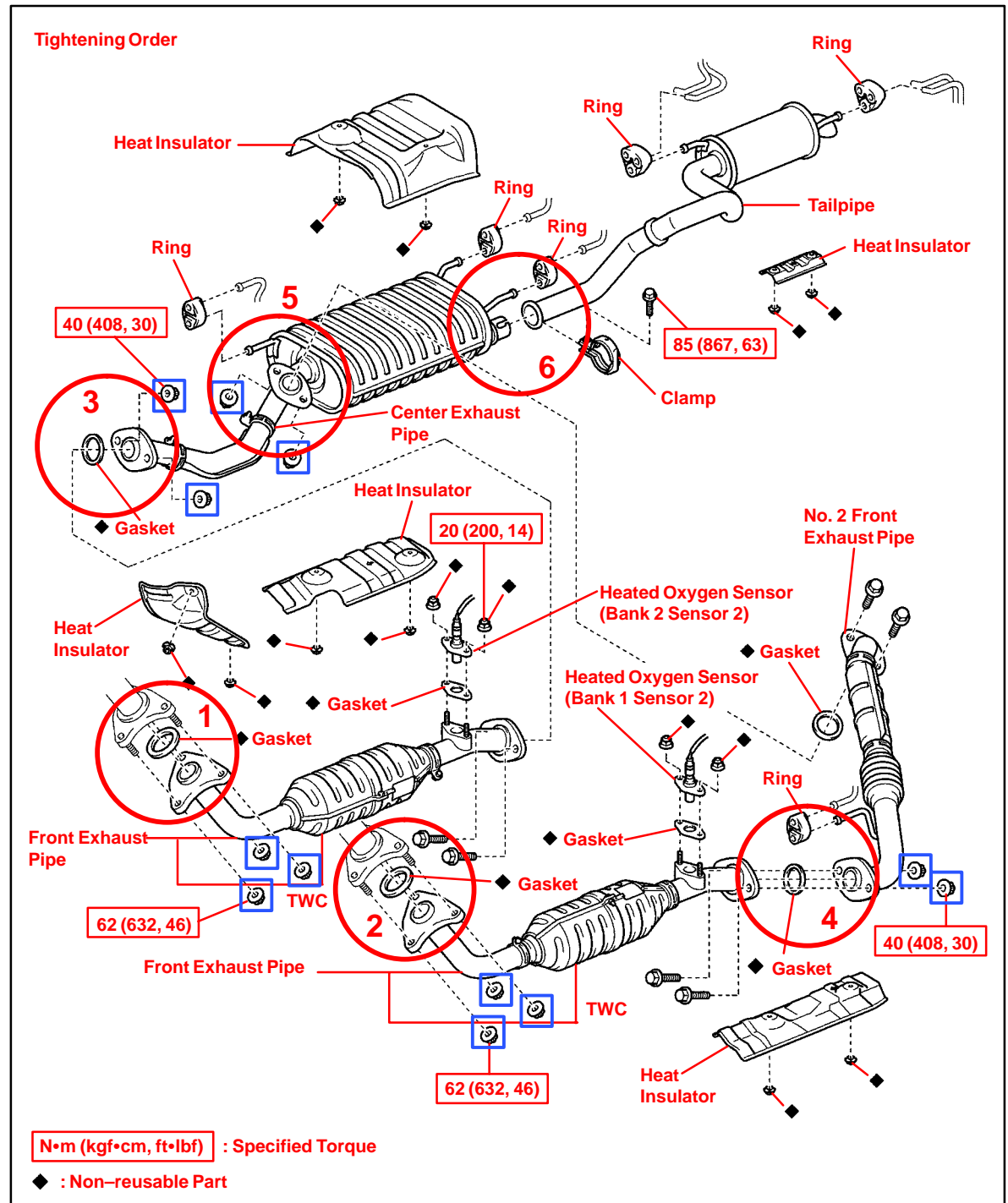

**Repair
Procedure B**
(Continued)

3. Check each exhaust pipe support clearance and compare to the specification listed below. Adjust each support to as near to the clearance specification as possible.

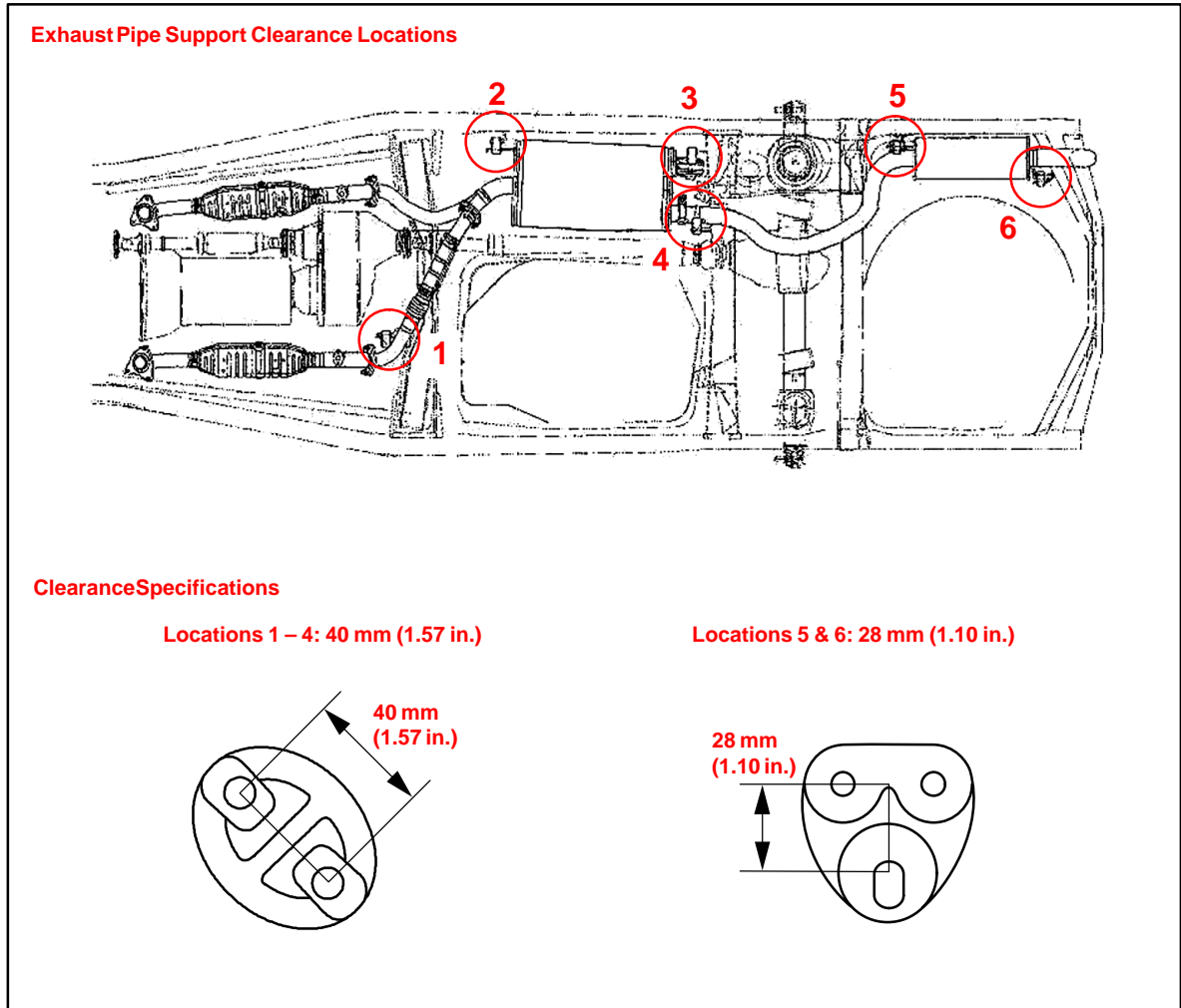

Repair
Procedure
C1 & C2

Install Driver's Side Crossmember Frame Damper Weight

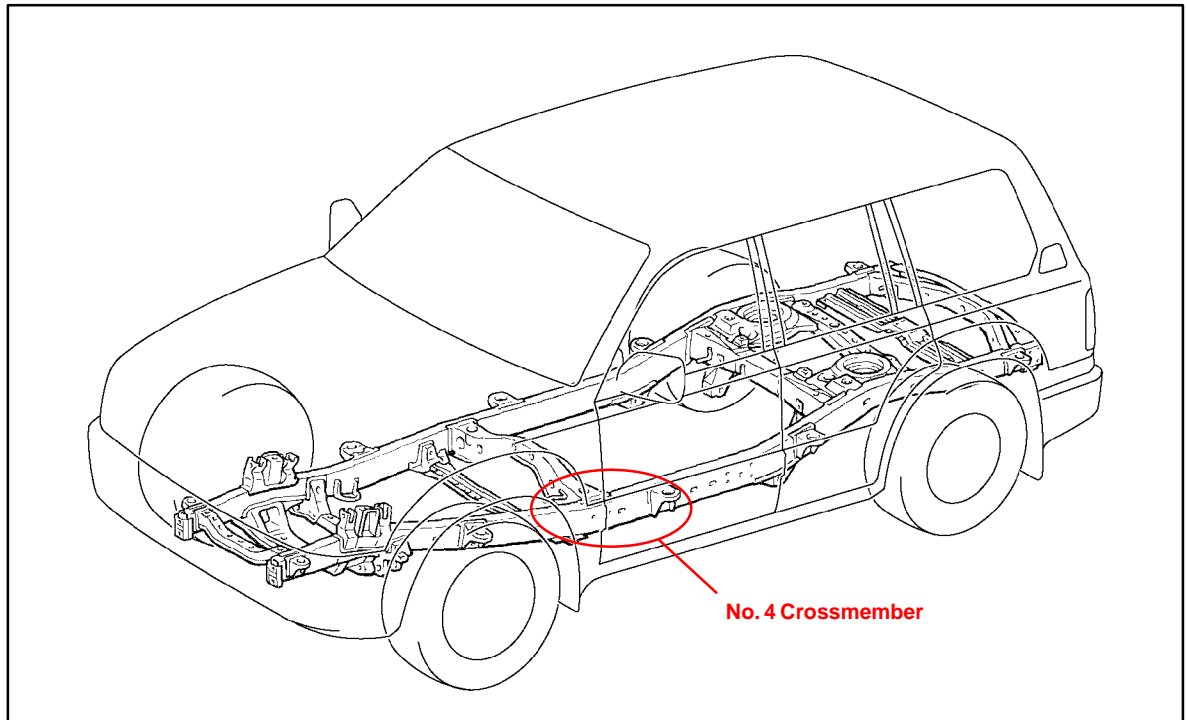

No. 4 Crossmember Damper Weight Installation

1. Check Bolt Hole.

- A. Check the 2 bolt holes located in the LH frame rail. If there are weld nuts, go to step 2–H.
- B. Check the 2 bolt holes located in the LH frame rail. If there are **NO** weld nuts, go to step 2–A.

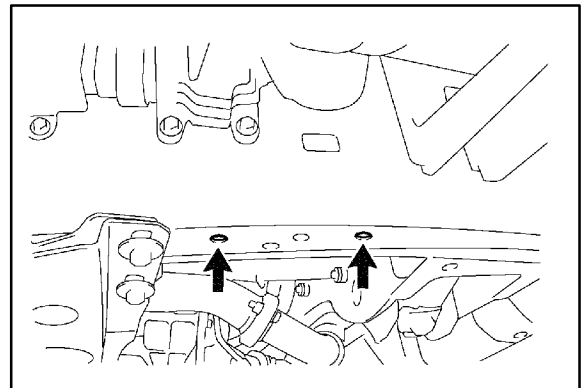

2. Install No. 4 Crossmember Damper Weight.

- A. Insert the wires into each bolt hole of the frame, and pull out the wires from hole "A."

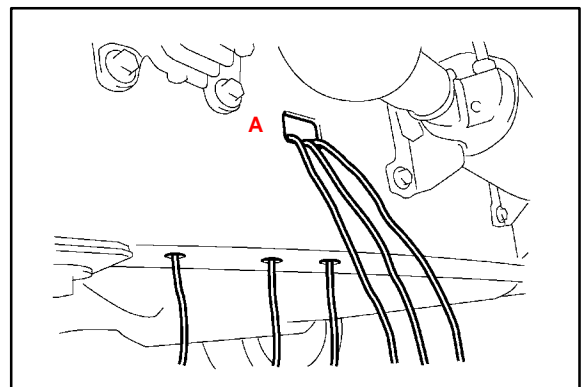

**Repair
Procedure
C1 & C2
(Continued)**

- B. Insert the 3 wires into the holes of the bracket at the direction shown in the illustration.

NOTE:

Due to the spacing of the bolt holes in the frame, be careful to install the bracket in the correct direction.

- C. Attach a nut to the center wire as shown in the illustration.

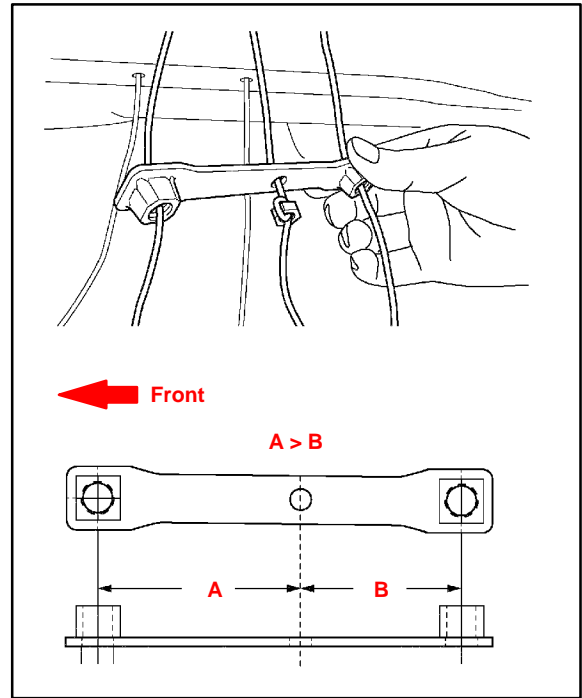

- D. Insert the bracket into hole "A" of the frame.

NOTE:

Ensure that the wires do not completely enter hole "A."

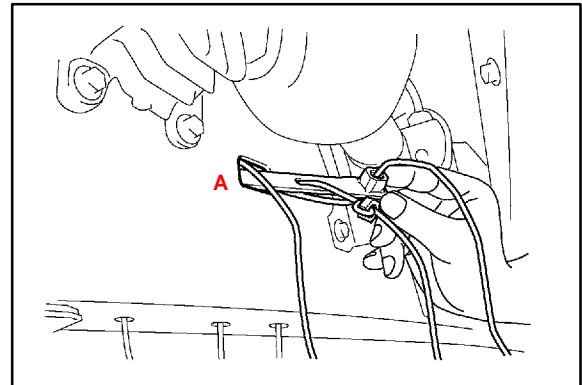

- E. Using the 3 wires, position the bracket and pull out the front wire through hole "A."
- F. Tighten the front bolt temporarily by pulling the center wire from the bottom and holding down the bracket.
- G. Using the wire at the rear side, position the bracket.

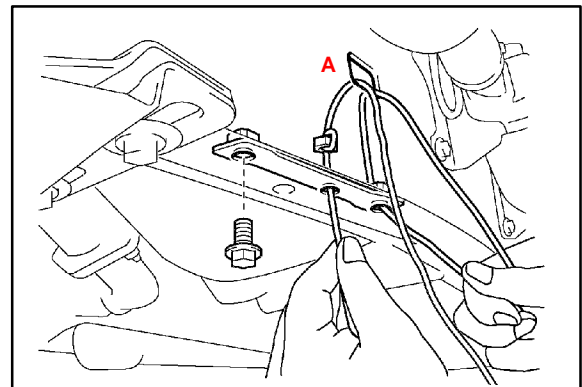

**Repair
Procedure
C1 & C2**
(Continued)

- H. Attaching the No. 4 crossmember damper weight, tighten the rear bolt temporarily.
- I. Remove the front bolt.

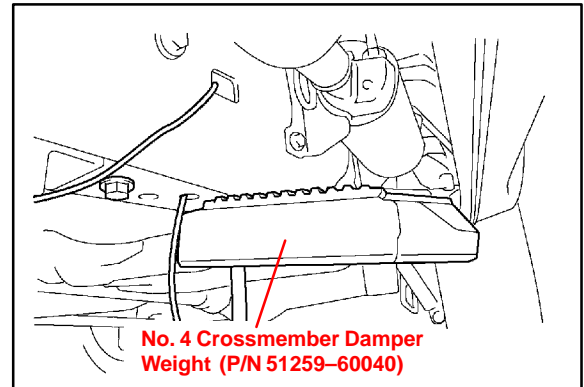

- J. Rotate the No. 4 crossmember damper weight, reinstall and tighten the front bolt.

HINT:

When rotating the No. 4 crossmember damper weight, pull the center wire from the bottom to press the bracket down.

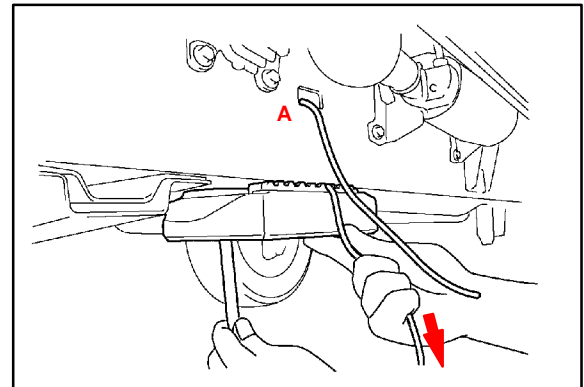

- K. Pull out the center wire from hole "A."
- L. Tighten the No. 4 crossmember damper weight with the 2 bolts.

Torque: 39 N•m (400 kgf•cm, 29 ft•lbf)

**Repair
Procedure D**

Loosen and Retighten Spare Tire

1. Loosen the spare tire.
2. Pull spare tire toward the rear of the vehicle as much as possible.
3. Retighten the spare tire.

**Repair
Procedure E1****Install Exhaust Pipe Damper**

1. Remove the heat insulator from the main muffler.
2. Remove the exhaust pipe damper from the main muffler.
3. Install the new exhaust pipe damper to the main muffler with the 2 bolts.

NOTE:

- The 5 exhaust pipe dampers are tuned to different frequencies (32 Hz, 39 Hz, 48 Hz, 43.8 Hz, and 34.6 Hz). Install each of the 5 exhaust pipe dampers to determine which is the most effective.
- Due to its larger size, when installing the 43.8 Hz damper, you **MUST** use a new heat insulator (P/N 17551-50091) in place of the original heat insulator.

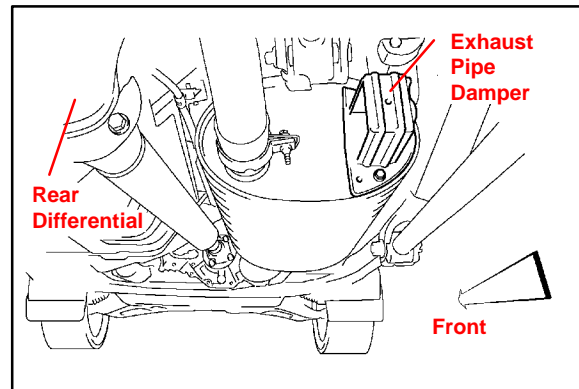

4. Install the appropriate heat insulator to the main muffler with the 2 nuts.

**Repair
Procedure E2****Install Exhaust Pipe Damper**

1. Remove the heat insulator from the main muffler.
2. Remove the exhaust pipe damper from the main muffler.
3. Install the new exhaust pipe damper to the main muffler with the 2 bolts.

NOTE:

The 5 exhaust pipe dampers are tuned to different frequencies (32 Hz, 39 Hz, 48 Hz, 43.8 Hz, and 34.6 Hz). Install each of the 5 exhaust pipe dampers to determine which is the most effective.

4. Reinstall the heat insulator to the main muffler with the 2 nuts.

**Repair
Procedure F****Install Passenger's Side Crossmember Frame Damper Weight**

1. Install the RH No. 4 crossmember damper weight.
 - A. Install the RH No. 4 crossmember damper weight by following steps H – L of Repair Procedure C2.
 - B. After installation, check the vibration level again. If vibration level is worse after installing the RH No. 4 crossmember damper weight, remove it and do NOT utilize this part.

NOTE:

For all model year vehicles, weld nuts are located in the passenger's side frame rail. Therefore, installation of the securing bracket inside the frame rail is not necessary.

**Repair
Procedure G****Replace Rear Engine Mount Insulator**

- Refer to TIS, applicable model year LX 470 Repair Manual: *Engine Mechanical: Exhaust Unit:Removal*.

NOTE:

This mount must be installed in the correct direction. Use the paint marks on the mount to determine correct installation direction.

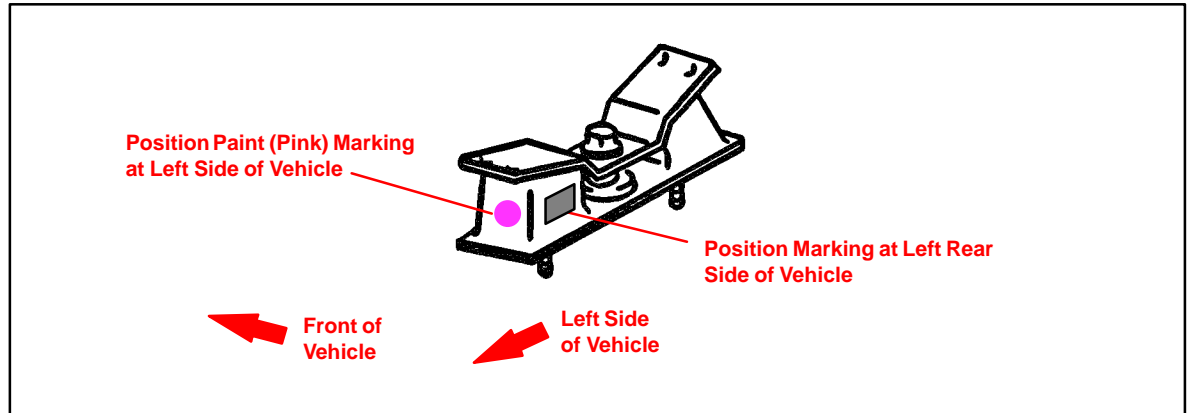
**Repair
Procedure H****Replace Front Engine Mount Insulator**

- Refer to TIS, applicable model year LX 470 Repair Manual: *Engine Mechanical: Exhaust Unit:Removal*.

NOTE:

Installation of these mounts may result in body vibration at driving speeds of 80 mph (129 km/h) or higher. If body vibration occurs, reinstall original engine mounts.