



**Technical Service
Information Bulletin**

January 7, 2004

Title:
**TILT/TELESCOPIC STEERING
NOISE/SMOOTHNESS IMPROVEMENT**

Models:
'98 – '03 LX 470

**STEERING
ST002-04**

Introduction Some 1998 – 2003 model year LX470 vehicles may experience steering column noise. The cable has been replaced with a universal joint to reduce the steering column noise. Follow the repair procedures described below.

Applicable Vehicles

- 1998 – 2003 model year LX 470 vehicles.

MODEL	APPLICABLE VEHICLE VIN RANGE	REPLACE PARTS*
'02 – '03 LX 470	JTJHT00W#23514198 to JTJHT00W#33530604	A
'98 – '02 LX 470	JT6HT00W#W0001038 to JTJHT00W#23514197	A and B

* Refer to Parts Information Table.

**Parts
Information**

PROCEDURE PARTS	PREVIOUS PART NUMBER	CURRENT PART NUMBER	PART NAME	QTY
A	N/A	45230–50020	Joint Assembly, Steering Shaft Universal	1
B	45766–60011	Same	Support, Telescopic Steering Slider	1
	45898–60020	Same	Bolt, Support Stopper	2

**Warranty
Information**

OP CODE	DESCRIPTION	TIME	OFF	T1	T2
ST3004	Steering Shaft Universal Joint Assembly Replacement	0.9	45767–60010	44	44
ST3005	Telescopic Steering Slider Support/ Steering Shaft Universal Joint	1.0			

Applicable Warranty*:

This repair is covered under the Lexus Comprehensive Warranty. This warranty is in effect for 48 months or 50,000 miles, whichever occurs first, from the vehicle's in-service date.

* Warranty application is limited to correction of a problem based upon a customer's specific complaint.



Steering
Column
Components

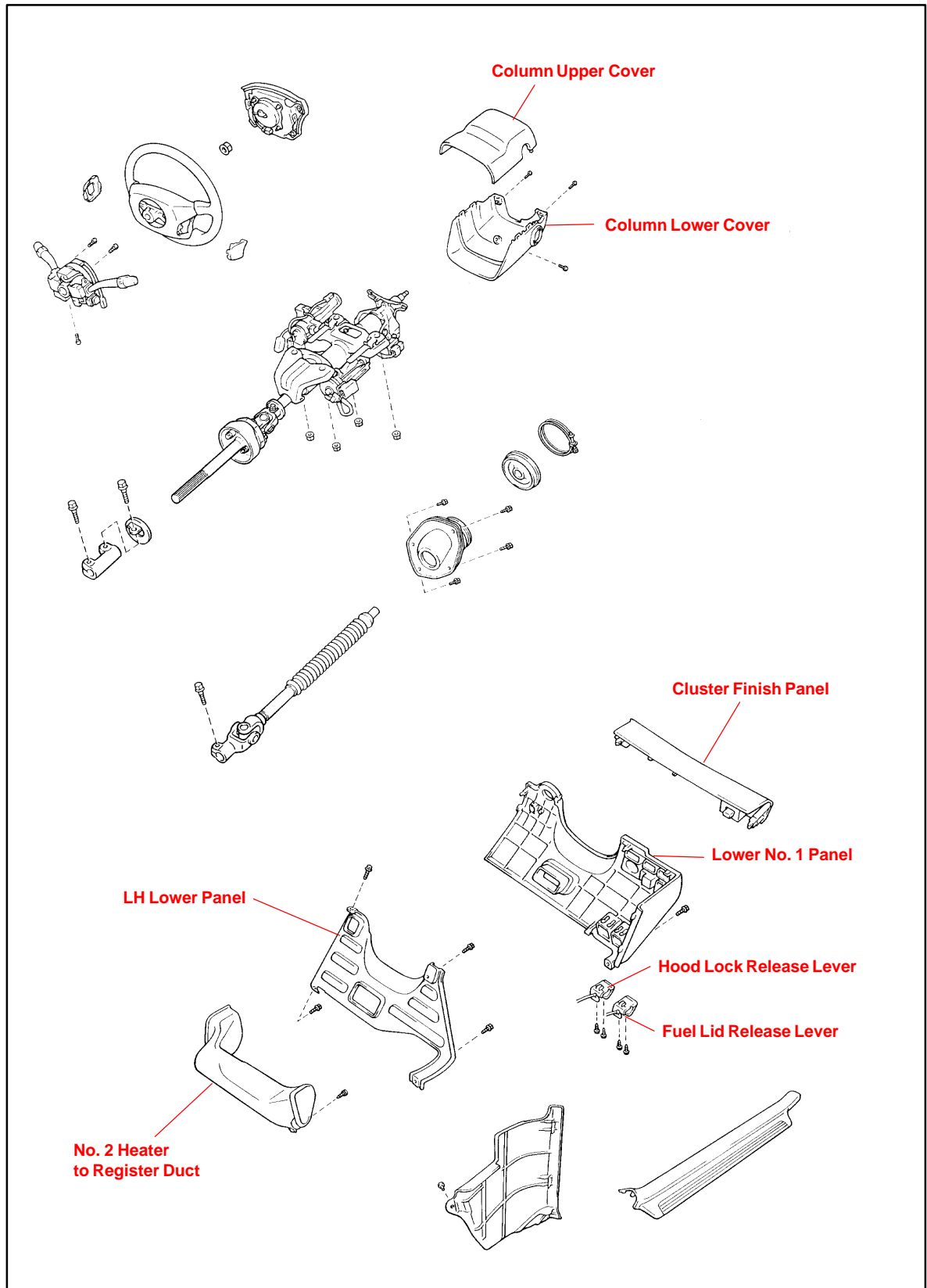

Steering Column Components
(Continued)

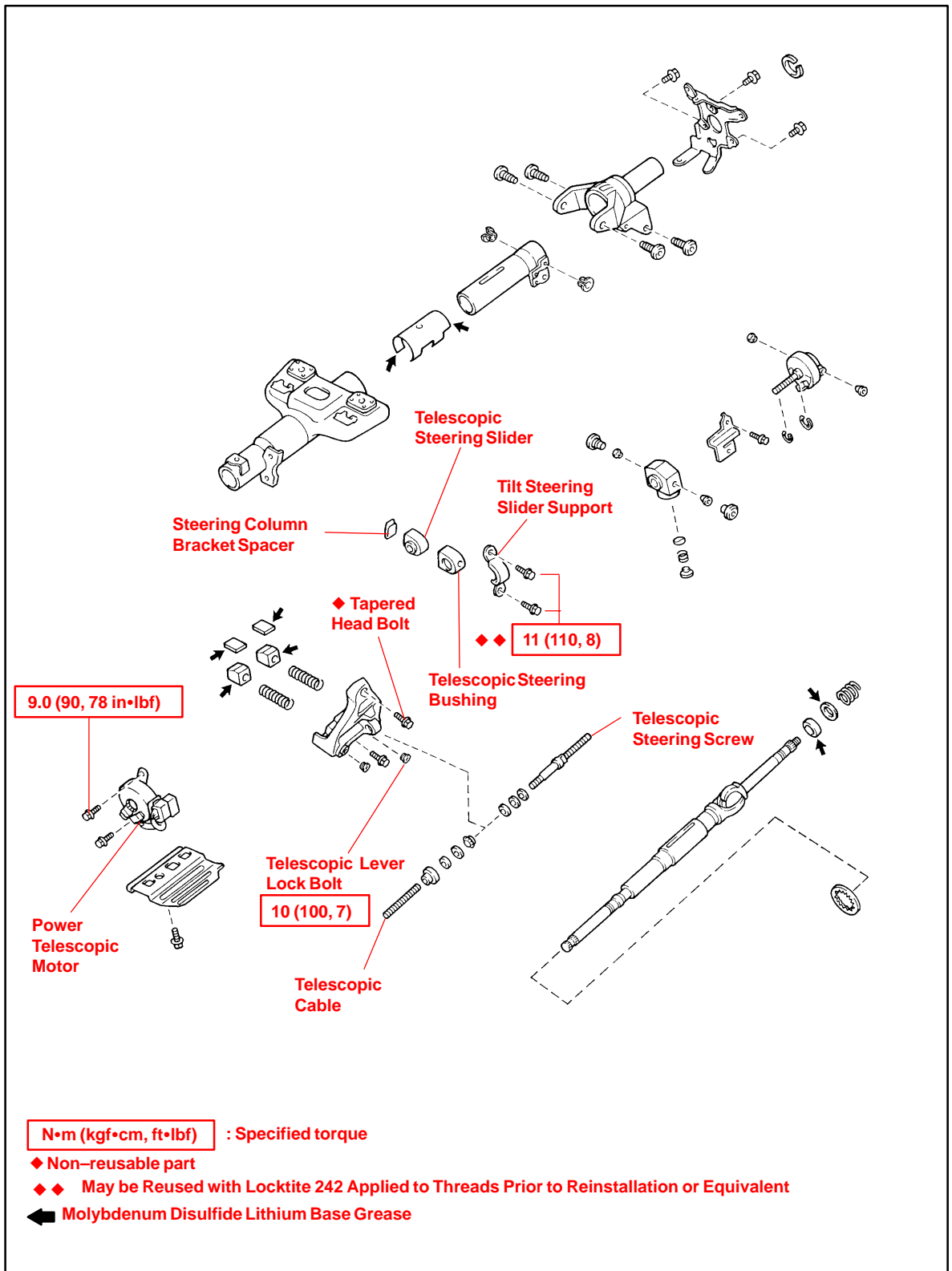

**Repair
Procedure:
Preparation**

1. **Remove Lower No. 1 Panel.**
 - A. Remove the 2 screws and disconnect the hood lock release lever from the panel.
 - B. Remove the 2 screws and disconnect the fuel lid release lever from the panel.
 - C. Remove the pad set screw.

NOTE:

Tape up the screwdriver tip before use.

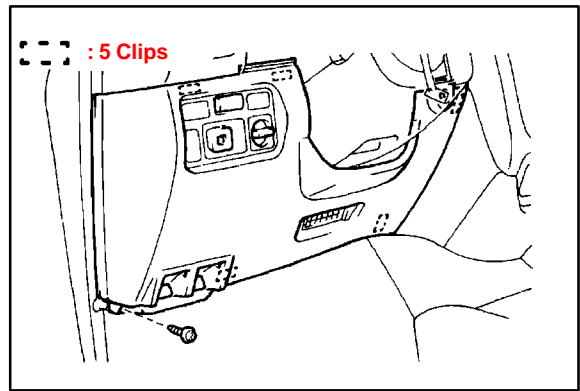

2. **Remove LH Lower Panel.**
 - A. Remove the 4 bolts and the LH lower panel.
3. **Remove No. 2 Heater to Register Duct.**
 - A. Remove the screw and the No. 2 heater to register duct.
4. **Remove Column Cover.**
 - A. Remove the 3 screws and the column cover.

**Repair
Procedure A**

1. **Remove Power Telescopic Motor.**
 - A. Remove the 2 bolts and the power telescopic motor.

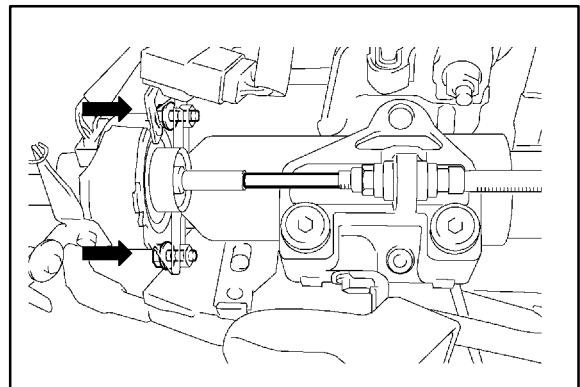

2. **Remove Telescopic Steering Column Cable Assembly.**
 - A. Remove the telescopic steering column cable.

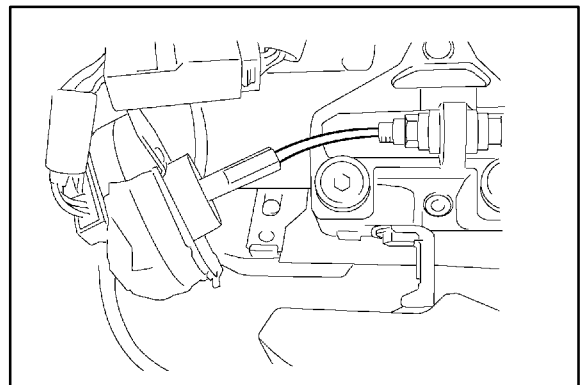

**Repair
Procedure A
(Continued)**

- 3. Install Steering Shaft Universal Joint Assembly.**
 - A. Install the steering shaft universal joint assembly.
 - B. Tighten the power telescopic motor with 2 bolts.

Torque: 9 N•m (90 kgf•cm, 78 in.•lbf)

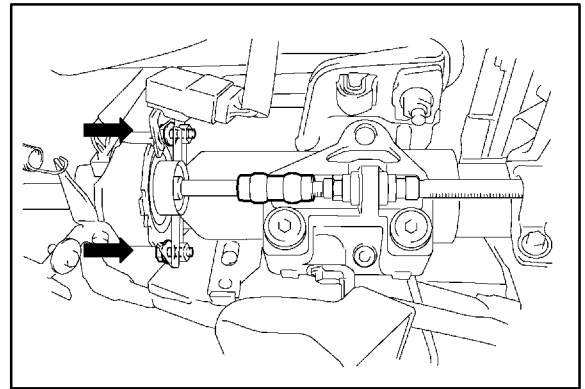

**Repair
Procedure B**

- 1. Replace Telescopic Steering Support and Support Stopper Bolts.**
 - A. Check the VIN number.
 - B. If necessary, replace the telescopic steering support and support stopper bolts.

Torque: 11 N•m (110 kgf•cm, 8 ft•lbf)
- 2. Inspect Power Telescopic Function.**
 - A. Connect the negative battery terminal.
 - B. Check that the power telescopic function operates properly.
 - C. Disconnect the negative battery terminal.
- 3. Install Column Cover.**
- 4. Install No. 2 Heater to Register Duct.**
- 5. Install LH Lower Panel.**
- 6. Install Lower No. 1 Panel.**
- 7. Connect Negative Battery Terminal.**

