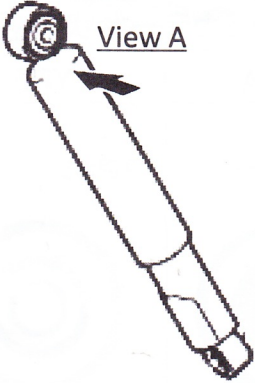
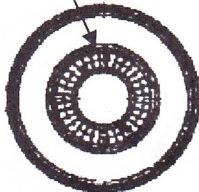
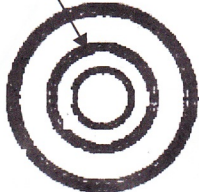

Installation Notice for Rr Shock Absorber

<Points to be checked>

1. Please confirm the shape of Rr Shock Absorber installed on the vehicle referring to the table below

Rr Shock Absorber	shape of bush collar (View A)	
	TYPE A	TYPE B
	serration collar 	not serration 

2. If the shape of bush collar is TYPE A, please make sure to process replacement of parts referring to Instructions below.

(If it is TYPE B, process below isn't required. Please refer to the instructions in repair manual.)
<Instructions>

1. Please make sure to fully comprehend points below for replacement of Rr Shock Absorber.
2. Bolt A was also changed. Please use New Bolt (P/N91552-K1260) instead.

◇ Installation of Rr Shock Absorber

- Please use New Bolt(P/N 91552-K1260) for Bolt A during Rr Shock Absorber's installation.
- Please discard and do not use Old Bolt .

◇ Final tightening process of Rr Shock Absorber

- Final tightening torque has been changed from 100N·m(1020Kgf·cm) to 90N·m(918Kgf·cm).
Please apply 90N·m(918Kgf·cm) to final tightening torque for New Bolt(P/N 91552-K1260) .

*Please refer to repair manual for more details of installation process etc.

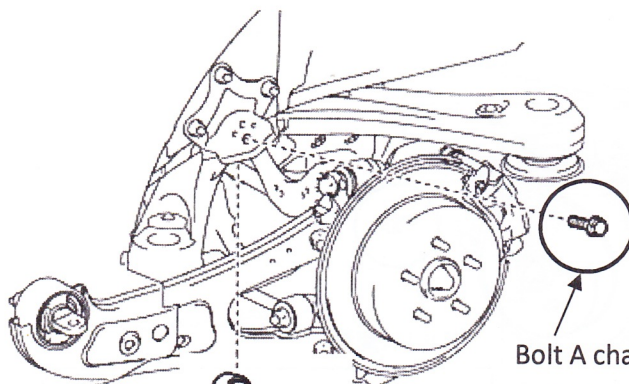

Rr Shock Absorber

Bolt A → New Bolt(P/N 91552-K1260)
Torque: 100N·m(1020Kgf·cm)
→ 90N·m(918Kgf·cm)