

# Highlander Hybrid Engine Block Heater Installation



By Evan E. Fusco, MD

*\*Disclaimer: I am not a certified mechanic nor am I an expert on working on cars. I am a hobbyist and tinkerer. I post these instructions only to assist others who might be interested in attempting to install an Engine Block Heater on their Highlander Hybrid. It is assumed those attempting have adequate tools, skills, and common sense to make adjustments. If you feel at all uncertain about your ability to begin or complete this installation please see a certified Toyota Service Center to perform the installation for you. I assume absolutely no liability if you damage your car or anyone else's during this installation or for any damage that might occur later as a result of it's installation whether you followed my instructions or not. This is for information purposes only.*

## What This Is:

These are instructions to assist in the installation of a Toyota Canada manufactured Engine Block Heater (EBH) into a 2006 Toyota Highlander Hybrid. It may be the same for future Model Year Toyota Highlander Hybrids, but it may not and you need to confirm this to be certain. It also should work for any 2004-2006 V6 non-Hybrid Highlander...but this also has not been confirmed and you should do so before proceeding.

## Time and Difficulty:

It took the author 4 hours to complete the installation. I would expect, with the assistance of these instructions, assuming you have all the appropriate tools, that

it could be accomplished in between 1-2 hours. Someone intimately familiar with the Highlander's engine compartment could probably do it in less than 1 hour.

I consider this moderately to very difficult. You're working in a confined space much of the time and it is difficult to get leverage to loosen or tighten various nuts/bolts/screws/plates. You should be fairly dexterous with your fingers and have all the recommended tools. There is nothing technical or complicated in this, but you do need to follow the instructions very carefully and be patient and diligent in completing some of the more difficult steps.

#### Tools & Parts:

1) Socket set—in particular a **10mm & 12mm socket**—having one each shallow and deep (deep is esp. important for the 12mm in order to get the old plate off) will help, if you have to choose choose the deep socket. If you can find one a **6mm Hex/Allen** that fits on a socket will help, but a regular Allen/Hex wrench will suffice. Ideally you need a **5mm Star socket** (the socket should go over the star shaped end of the stud, not a star shaped socket that goes into a screw



head), if you absolutely can't find that then a **5mm regular socket** will probably work, but you risk stripping the studs). You should also have a selection of screwdriver handles, a small socket wrench, a medium wrench, and an extension for your socket wrench.

2) A standard size **Phillips Head Screwdriver** and **Flat Head Screwdriver**.

3) **Vinyl tubing**—I think it's  $\frac{1}{4}$ " diameter that I used. What I ultimately found and used was an *Aqua Culture Mini Gravel Vacuum Cleaner*



for an aquarium that I found in the Fish supply section of Wal-Mart (~\$5). The tubing was 72" long and that was just right. Surgical rubber tubing would also work fine. The firmer vinyl tubing use for home freezer lines will NOT work...it's too small and inflexible. It's also NOT the smaller caliber tubing used for fish tanks, this is closer to 1/4". You need a softer vinyl that will stretch slightly over the drain and vent tubes.

4) **Car Ramps** or **Jack Stands** You'll be under the car a bit and having the space is very nice. Decent ramps at Wal-mart were under \$30.



5) A **6mm Allen/Hex Wrench**. I'd have one available even if you have the Allen Socket above since the socket may not reach some spots.

6) Either 2 **1-Gallon Milk Jugs**...very clean. Or some other 1 ½ gallon plus clean jug. You will only be draining a pint over 1 gallon, but this may vary so be prepared for 2 gallons. It is also reused so your container must be free of contaminants and it's nice to be able to close it up to prevent spillage and contamination.

7) Band-aids for scraped knuckles.

8) And, of course, an **Engine Block Heater**.



There are probably multiple sources available for this part....perhaps even in the US. But mine is Canadian made and was ordered from Langley Toyotatown at Toyotadepot.com.

[http://www.toyotadepot.com/product\\_info.php?products\\_id=151&osCsid=e40fc6ca3d610f03fa3b082746166757](http://www.toyotadepot.com/product_info.php?products_id=151&osCsid=e40fc6ca3d610f03fa3b082746166757)

If you want to try calling them or checking other sources it is **part # C0140-00644**. I don't know if this is a temporary supply issue or what as they currently don't list any Highlander part at all. I would e-mail them to check the status.

Someone also suggested an alternative that may work but I have not tried, tested, nor hear of anyone trying/testing and it may be a bit simpler of an installation thanks to a V-Loc connection system and it may not require the removal of the old studs from the Internal Combustion Engine (ICE). (see: [www.phillipsandtemro.com/Files/US\\_ZEROSTART\\_CATALOG\\_05\\_website\\_no\\_cover\\_s.pdf](http://www.phillipsandtemro.com/Files/US_ZEROSTART_CATALOG_05_website_no_cover_s.pdf)) It is the ZeroStart Part No. 3100029 for the 1MZ-FE engine as well as the 2004-2005 Toyota V6 3.3L which is the ICE that is in the HiHy.

9) Funnel

## Installation

\*Let car sit at least 1-2 hours after use before starting so it will not be too hot.

1)Put car on ramps or Jack up (see owner's manual) and put jack stands in place. Be sure to put on the parking brake and use chocks on the rear wheels.

2)Remove the Engine Under Cover.

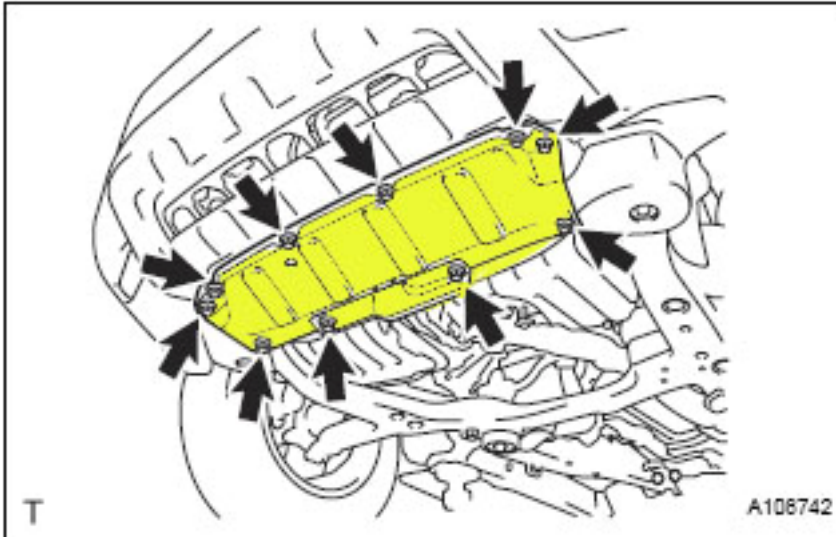

There are 2 stays that snap



out.  
stays in a safe place.

Put screws, cover and

3) Remove the cover over the radiator.



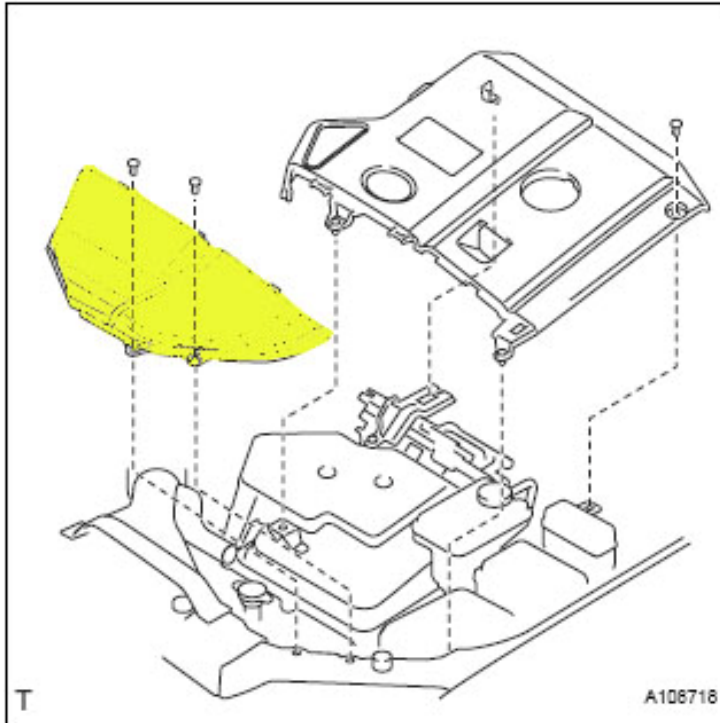

Radiator Drain Cock Plug  
(Equipped with Vent Plug)

Radiator Cap

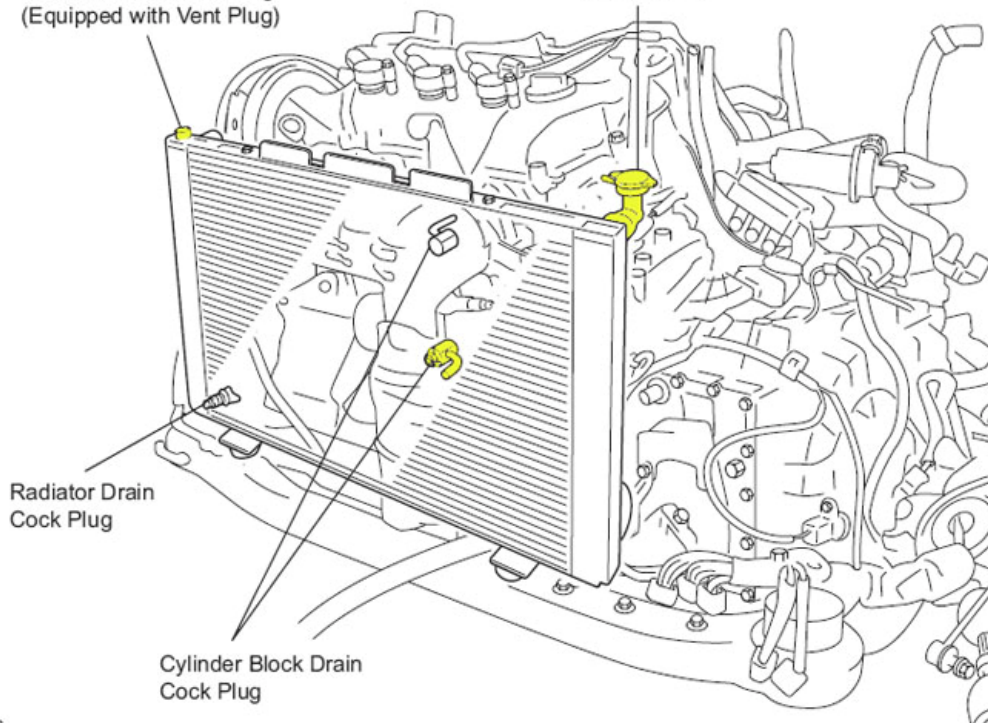

Removing those stays is tricky, I broke both in the process. If someone knows the proper technique to take them out without breaking them please let me know (email below). Note, we are NOT removing the cap from the coolant reservoir, but the radiator cap itself on the driver's side of the car under the black plastic cover just in front of the inverter. Remove the radiator cap.



4) Remove the 2 bolts and one nut holding the metal cover over the manifold.



This will loosen it up enough to help you see from above and access some of the parts (coolant drain plug, EBH nuts, etc) from above as well. Some of the Toyota instructions say to completely remove the manifold. While I have no doubt this would improve access dramatically I did not do it as I have no idea what's involved in getting it back on properly.

5) Identify the Engine Coolant drain plug and attach the drain hose with the hose running down and under the HiHy to one of the milk jugs.

Radiator Drain Cock Plug  
(Equipped with Vent Plug)

Radiator Cap

Radiator Drain  
Cock Plug

Cylinder Block Drain  
Cock Plug

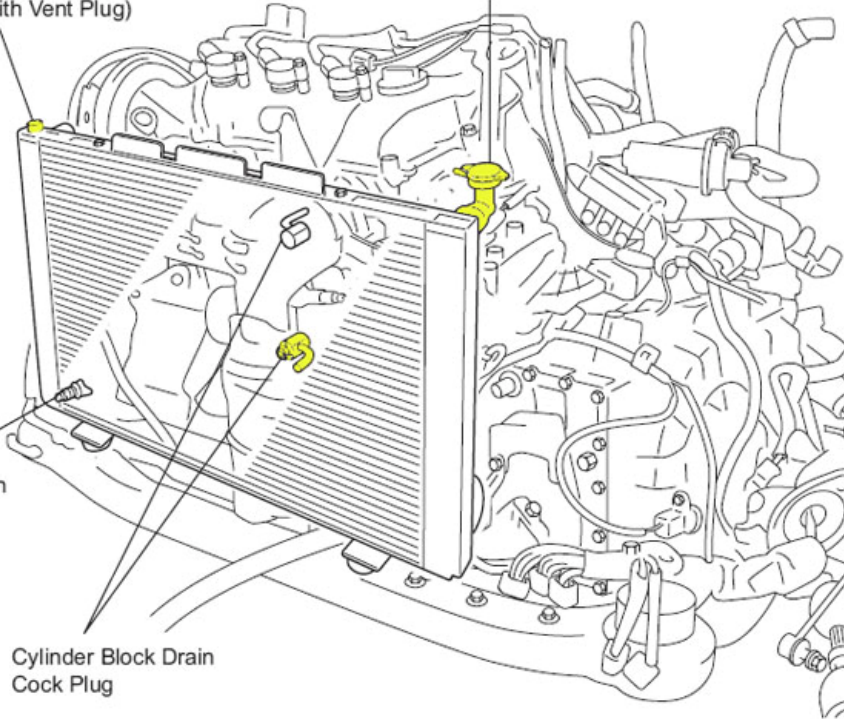

C

A108260E01



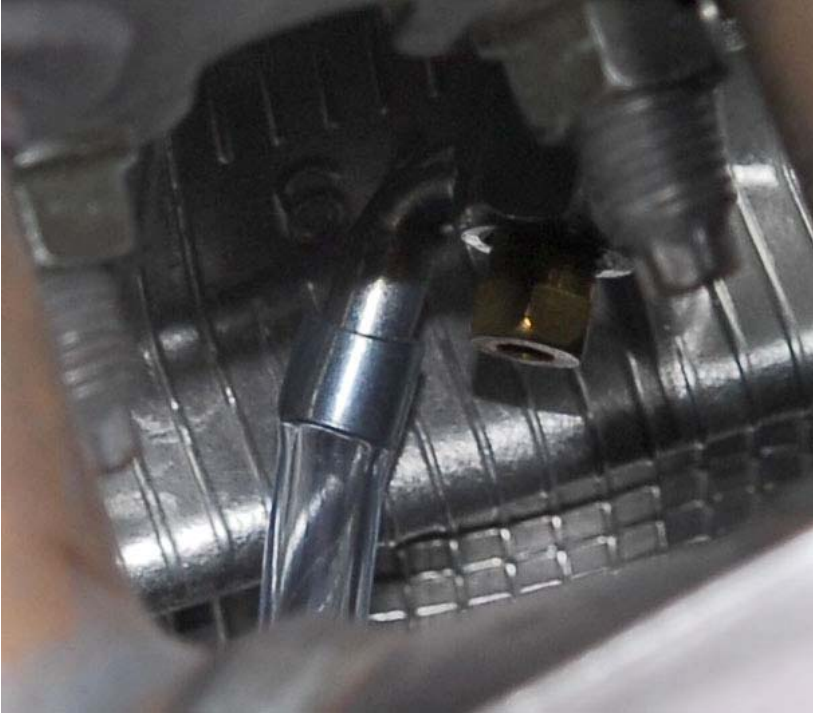

Use the 10mm socket and open the drain. Allow as much coolant to drain as will drain out.



Note: We are NOT opening the radiator drain...it's not necessary for the EBH install. It should drain just a bit over 1 gallon. Once it stops draining tighten the Engine Coolant plug and remove the vinyl hose.

6) From below the car reach up and remove the nuts holding the plate on the engine where the EBH will be inserted. It is right next to the Oil filter on the passenger side of the filter.

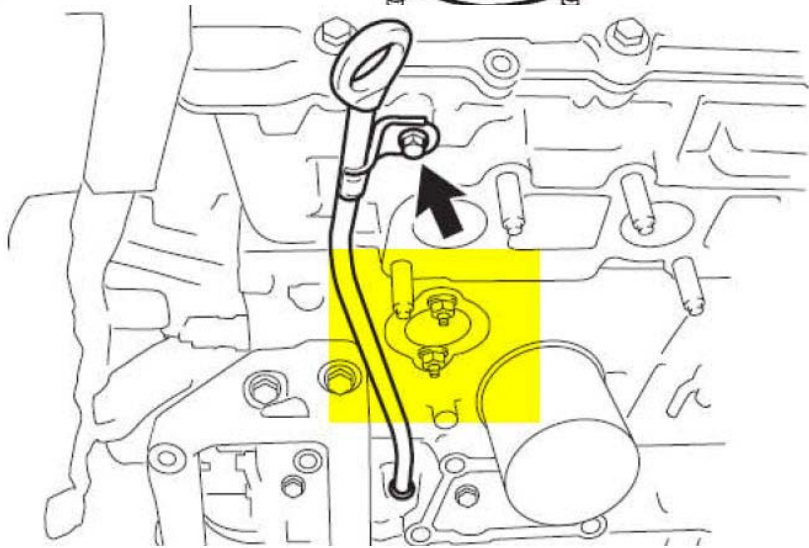
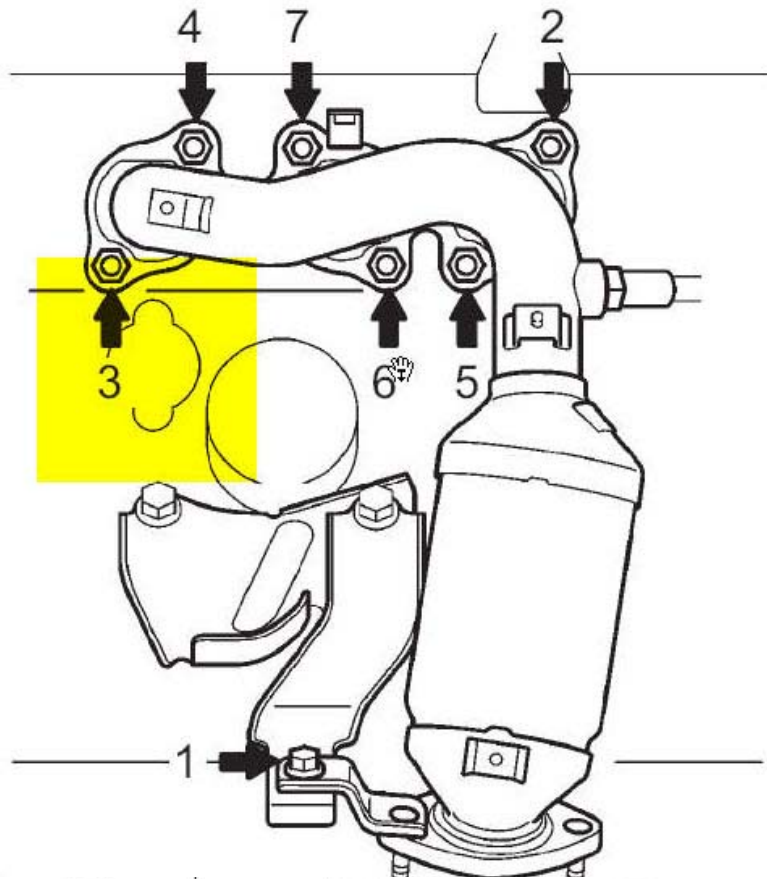





You probably don't have to worry about any leakage here as there is a strong sealant holding the plate on.

7) Remove the plate. This, I found, was one of the two most difficult parts of the installation. I used a flat head screw driver and wedged it b/w the plate and the engine block then twisted, tapped, levered, etc until I got the plate to loosen up. It will, but it isn't easy...or wasn't for me...b/c it's difficult to get leverage in the space.

8) Put your finger in the hole and carefully remove the old O-ring and any residual sealant inside the hole or making the outside not smooth.

9) Use your star socket or 5mm regular socket and remove the old studs/bolts that are screwed into the engine block that were holding on the old plate.



These also require a decent amount of force to break free, but once they break free they come off easily. Note that if they do strip you may have to resort to using vice grips to get a firmer grip. They come out in a normal counter clockwise rotation. Remove both completely.

10) Use the silicone lubricant and seal the O-ring on the new EBH.



Insert it into the hole until firmly seated. Note that ideally the prongs for where the cord will plug in should be 180 degrees opposite from how I have mine



positioned.

It's not critical, but will make plugging the cord into it more logical and a little easier.

11) Place the retaining plate over the EBH with the prongs/flanges facing TOWARD the engine. Try as I might the other way I just couldn't seat the bolts properly.

12)Screw in the new bolts using the locking washer. Tighten firmly (but don't over tighten) with the 6mm Hex wrench or hex socket.

13)Thread the cord for the EBH how you like.







I went through the passenger side of the lower grill.



There's a tiny gap that you can sort of force a little wider on the lower front bumper to get to the area behind that black grid shaped grill that then gives easy access to the engine compartment. I then plugged the orange connector into the EBH and secured the cord to a bracket nearby with a zip-tie. I also used a zip-tie to secure the plug-end of the cord right near the radiator. With this location I can tuck the cord completely behind the bumper when not in use so it's completely out of site, yet easy to get to when needed.

14) Replace the Lower Engine Cover.

15) Back HiHy off ramps or remove jack stands and lower the vehicle...make sure you got everything out from underneath.

16) Loosen the upper radiator drain cock plug with the 6mm hex. Attach your vinyl tubing to the vent tube.

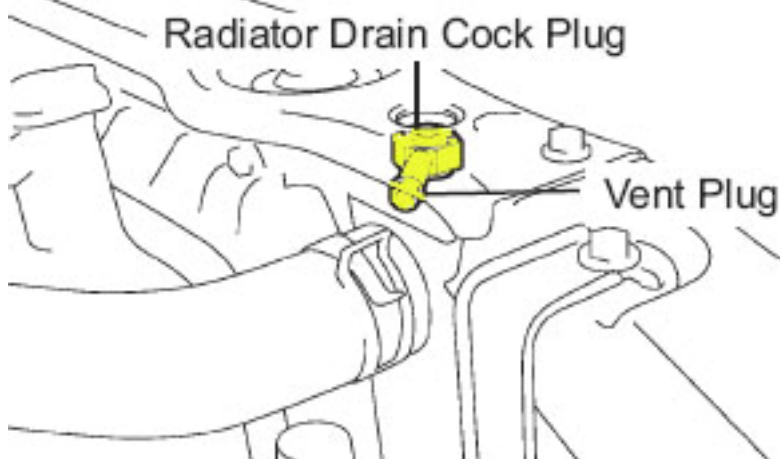

You'll watch there to see

when your coolant is full as the tube will begin to

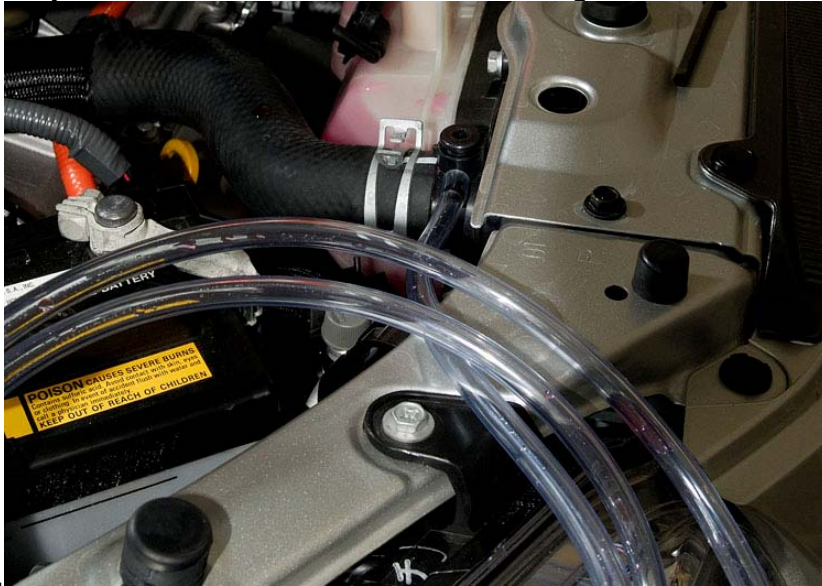

fill.

17) Very slowly and carefully start pouring the coolant back into the radiator through the funnel. It won't go in very fast so be patient.



Once the radiator and vent tube start to show overflow you've got enough in. If you have any left just pour it in the reservoir.

18) Tighten the upper radiator fill plug, remove the vinyl tubing, close the radiator cap, and replace the plastic cover over the radiator.

19) Start up the HiHy and let it run a bit to circulate the coolant. While the ICE is running check underneath carefully for leaks (not just spillage from the install, but new leaking since refilling). If you see any shut down the car and return to tighten the EBH bracket up better. Make sure your bolts aren't cross threaded and that you've very firmly tightened them down.

**You're done!!!** Plug it in and see if your engine warms up. Alternatively, if you have a wattage meter like the Kill-a-watt meter you can see if it is drawing appropriately. Mine draws around 570 Watts...the EBH is rated at 600W and 120V.



I use a timer set to come on 2-4 hours before I leave for work on most days. This brings the coolant temperature up to around 130°F. That way I don't use any more electricity than necessary, but still start out with a prewarmed ICE that allows stealth mode and shortens the warm-up cycle considerably. Also, you get heat much more quickly on cold mornings.

\*\*\*\*\*  
\*\*\*\*\*

Comments/suggestions: [evanfusco@aol.com](mailto:evanfusco@aol.com)

Thanks to Rick (unk. Last name), one of the Toyota Hybrid mechanics who supports and helps out on Priuschat.com and HiHychat.com

This article is copyrighted by Evan E. Fusco, MD. I will freely give permission to use IF you ask me first an I approve the location and any changes you wish to make. If, however, us use it illegally without my permission I will pursue legal action against you for monetary compensation.