



4540 West 160th Street
(800) 403-7953
Cleveland, Ohio 44135
FAX: (216) 362-6342

Instructions for Use of MARADYNE[®] accessory wiring kits

General: MARADYNE[®] uses only high quality wiring kits, using only premium SAE GXL wire & sealed fuse holders. The relay holders of the harnesses slide together; and the harnesses interconnect with “bullet” terminals for a neat, professional appearance. The installer assumes responsibility to replace the 30 amp fuses supplied, with those recommended by the fan manufacturer for each application. MARADYNE[®] provides fuse recommendations with each fan. It is the installer’s responsibility to secure the wiring away from high temperatures, areas where the insulation may be cut and to insulate any wire connections left exposed at completion.

Radiator Fan Harnesses.

These are all the same wire harness. Part Number varies due to the temperature switch supplied.

MFA100 has an adjustable thermostat with remote sensing bulb. The thermostat may be adjusted to engage at any temperature from 32F to 248F. The bulb is normally inserted into the radiator fins on the inlet water side. It must fit securely, and should be inserted close to the radiator tank. For consistent operation, the sensing bulb should not be in an area of high airflow. The installer may make a pilot hole thru the radiator fins using a #1 or #2 screwdriver, however care must be used to avoid damaging the radiator tubes.

Both MFA102 and MFA103 have an internally grounding 3/8” male pipe thread temperature switch. This switch normally screws into the intake manifold, or in some cases the thermostat housing. When mounted in any location on the engine side of the thermostat, the temperature switch must engage the fan at a higher temperature than the opening temperature of the engine thermostat to prevent the fan(s) running full time. In some instances, it may be inserted into the inlet water tank of the radiator. NOTE: Before grounding any electrical circuit thru a radiator, the manufacturer should be consulted.

MFA102 has a nominal setting of 185F ON and 170F OFF. This switch is identified by black color code.

MFA103 has a nominal setting of 200F ON and 185F OFF. This switch is identified by red color code.

These harnesses have a circuit in parallel with the ‘Temp Switch’ labeled ‘Fan Switch’. This connects to a fan pressure [2 wire] or Trinary [4 wire] switch, which is either standard or optional on many aftermarket A/C kits. This is the most efficient method to control a fan in A/C mode,

engaging it only when the fan is required to lower the discharge pressure. MARADYNE® does not sell these pressure switches. For racing applications, where it is desired to manually engage the fans, a toggle switch may be mounted within the passenger compartment and connected to the 'Fan Switch' terminals.

MFA101 Condenser Fan Harness

MFA101 is used to engage an electric fan in conjunction with the Radiator Fan Harness. In this application, the fan will be engaged any time the compressor clutch is engaged. It may also be used to engage an auxiliary electric fan, only when the A/C clutch is engaged.

MFA111 Dual Fan Adapter Harness

MFA111 is used to engage a second electric fan in conjunction with the Radiator Fan Harness.

Typical Wiring Diagrams

Radiator Fan Only – No A/C

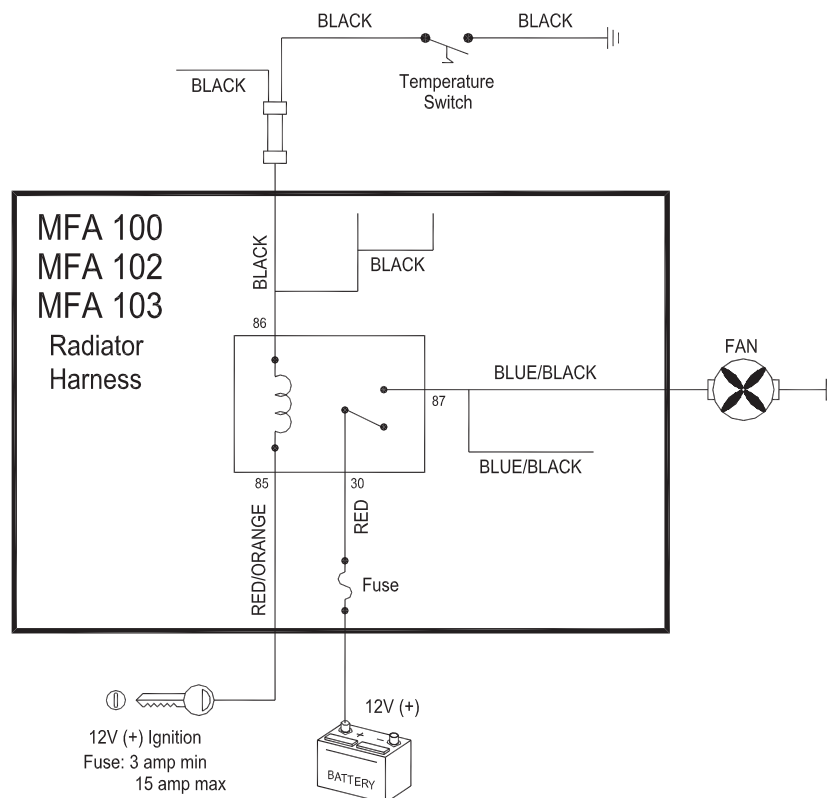

Radiator Fan with A/C with Fan Pressure Switch.

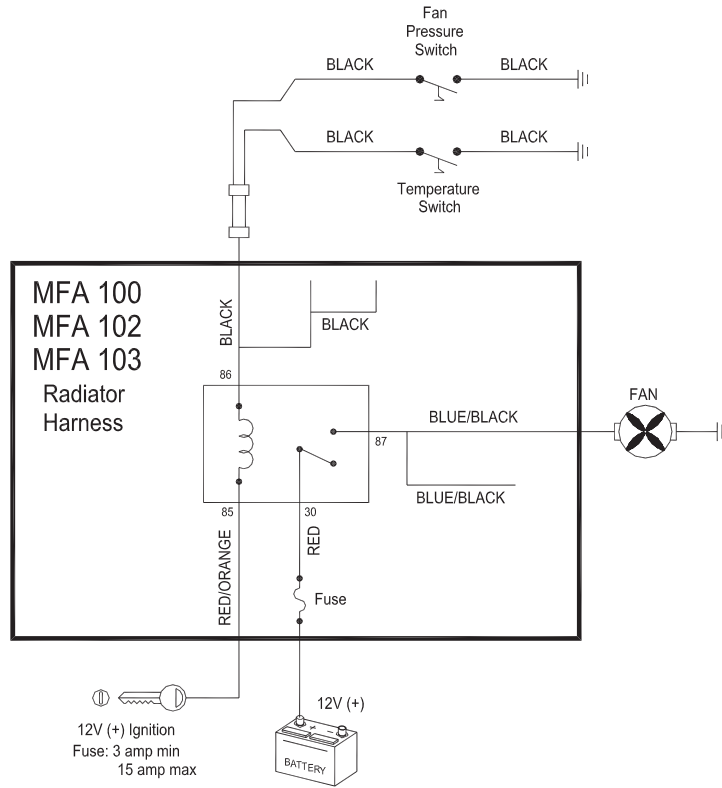

Radiator Fan with A/C, without Fan Pressure Switch with Positive Switched Compressor

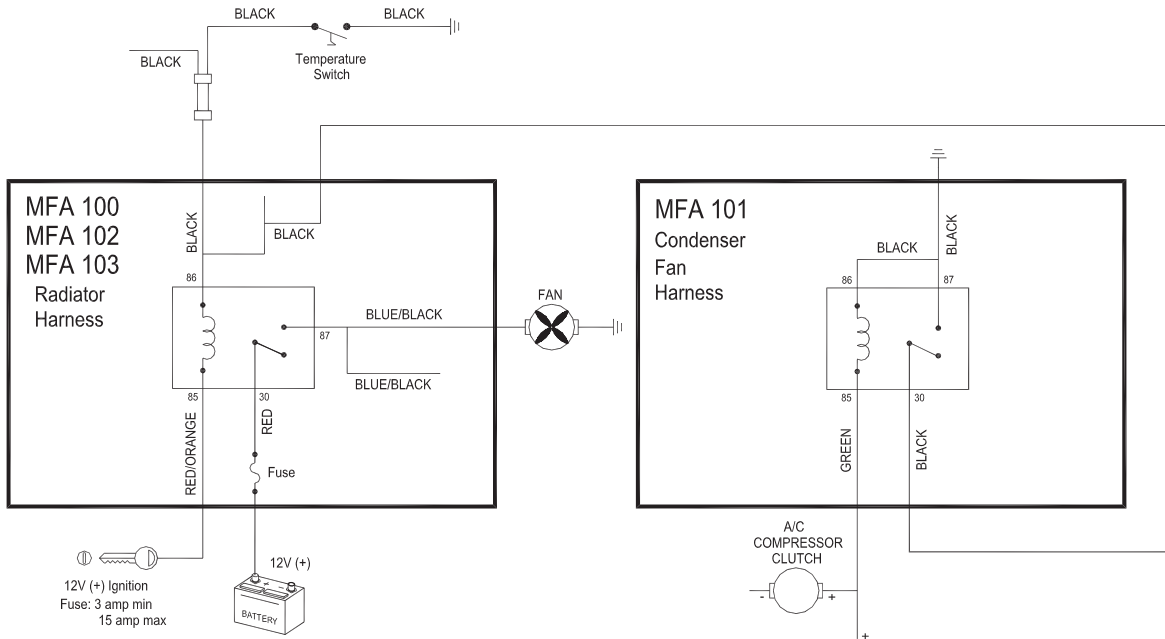

Two Fans with A/C, without Fan Pressure Switch with Positive Switched Compressor

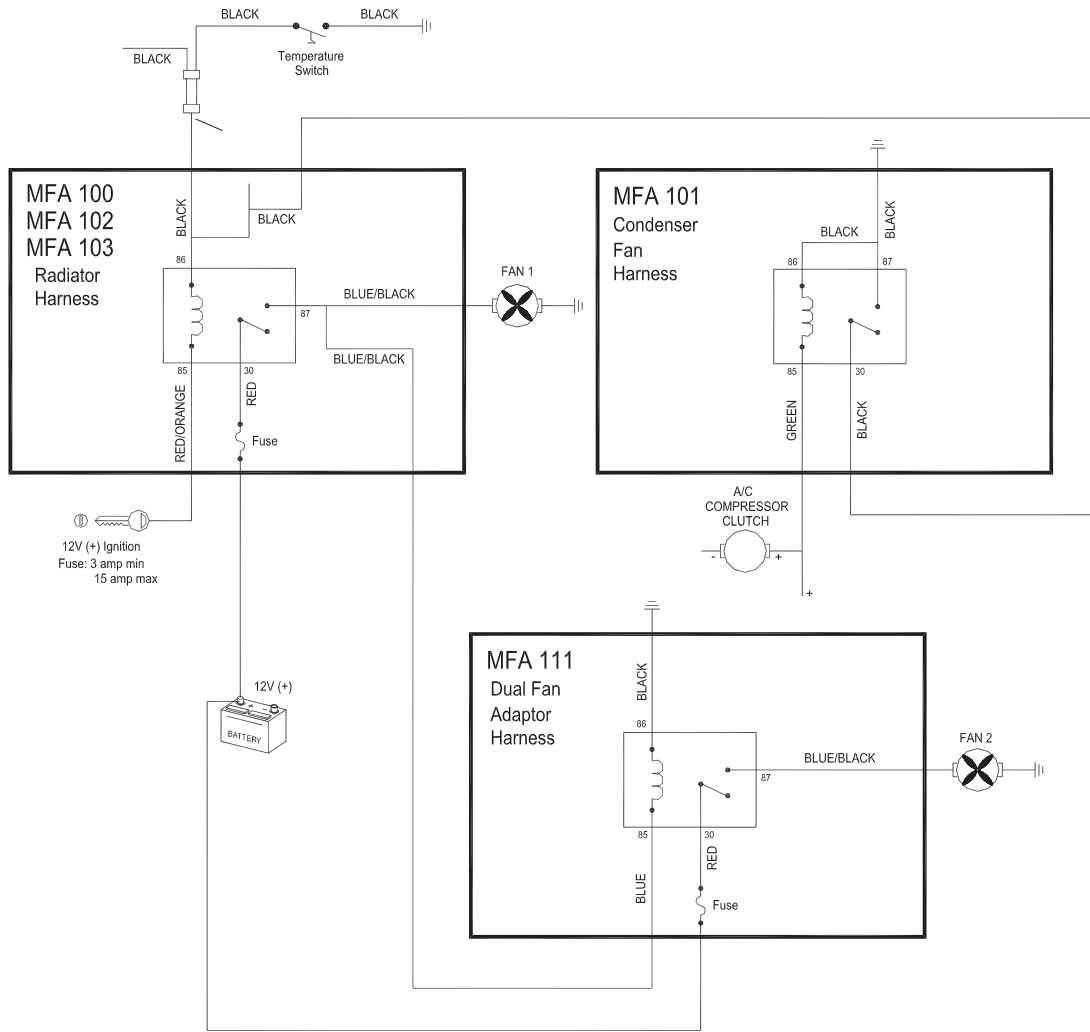

Condenser Fan Only without Fan Pressure Switch

