



**Technical Service  
Information Bulletin**

January 18, 2002

Title:

**NOISE FROM REAR SUSPENSION  
MEMBER**

Models:

'02 SC 430

SUSPENSION  
SU001-02

**TSB UPDATE NOTICE:**

The information contained in this TSB updates SU004-01 dated November 9, 2001. Revised text is **red** and **underlined**.

**Introduction** The internal shape of the rubber cushion has been changed to eliminate noise from the rear suspension member. The following procedure outlines the replacement of the cushion.

- Applicable Vehicles**
- 2002 model year **SC 430** vehicles produced before the VIN shown below.

**Production  
Change  
Information**

MODEL	STARTING VIN
2002 SC 430	<u>JTHFN48Y#20022000</u>

**Parts  
Information**

PREVIOUS PART NUMBER	CURRENT PART NUMBER	PART NAME	QTY
52271-24050 or <u>52271-24060</u>	<u>52271-30080</u>	Cushion, Rear Suspension Member Body Mounting, Front	2
90917-06078	Same	Gasket, Exhaust Pipe	4
90177-10001	Same	Nut, Exhaust Pipe	8

**Required Tools  
& Material**

SST PART NUMBER	SST NAME	QTY
09608-06041 (09608-06040)	Front Hub Inner Bearing Cone Replacer	1
09950-00020	Bearing Remover	1
09950-40011	Puller Set B	1
09950-50013	Puller Set C	1
09950-60010	Replacer Set	1
09950-60020	Replacer Set No. 2	1
09922-10010	Variable Open Wrench	2

**Warranty  
Information**

OP CODE	DESCRIPTION	TIME	OPN	T1	T2
SU1002	R & R Rear Suspension Member Body Mounting Cushion (Front)	4.0	52271-24050	91	99

**Applicable Warranty\*:**

This repair is covered under the Lexus Comprehensive Warranty. This warranty is in effect for 48 months or 50,000 miles, whichever occurs first, from the vehicle's in-service date.

\* Warranty application is limited to correction of a problem based upon a customer's specific complaint.



Components

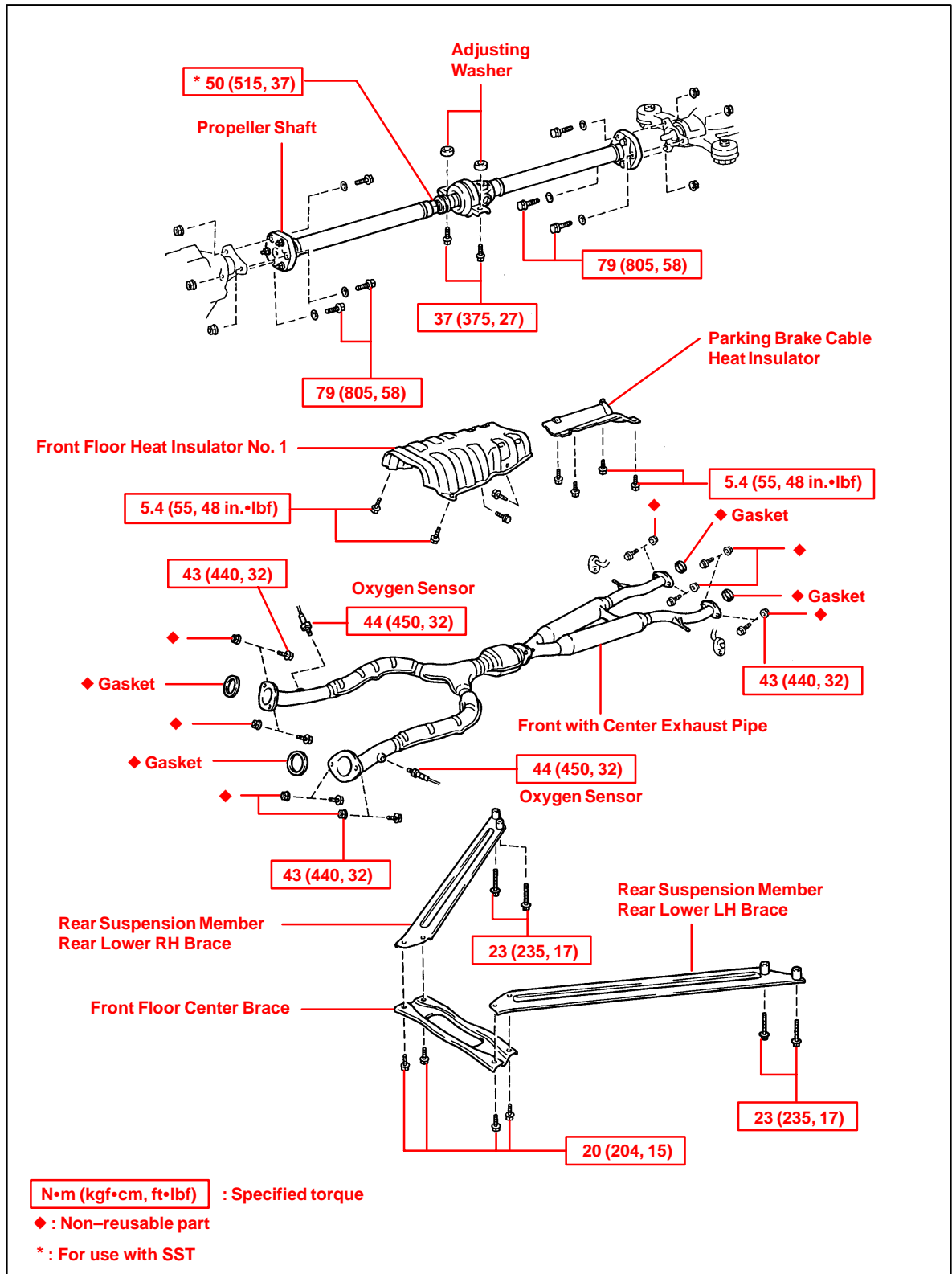

Components  
(Continued)

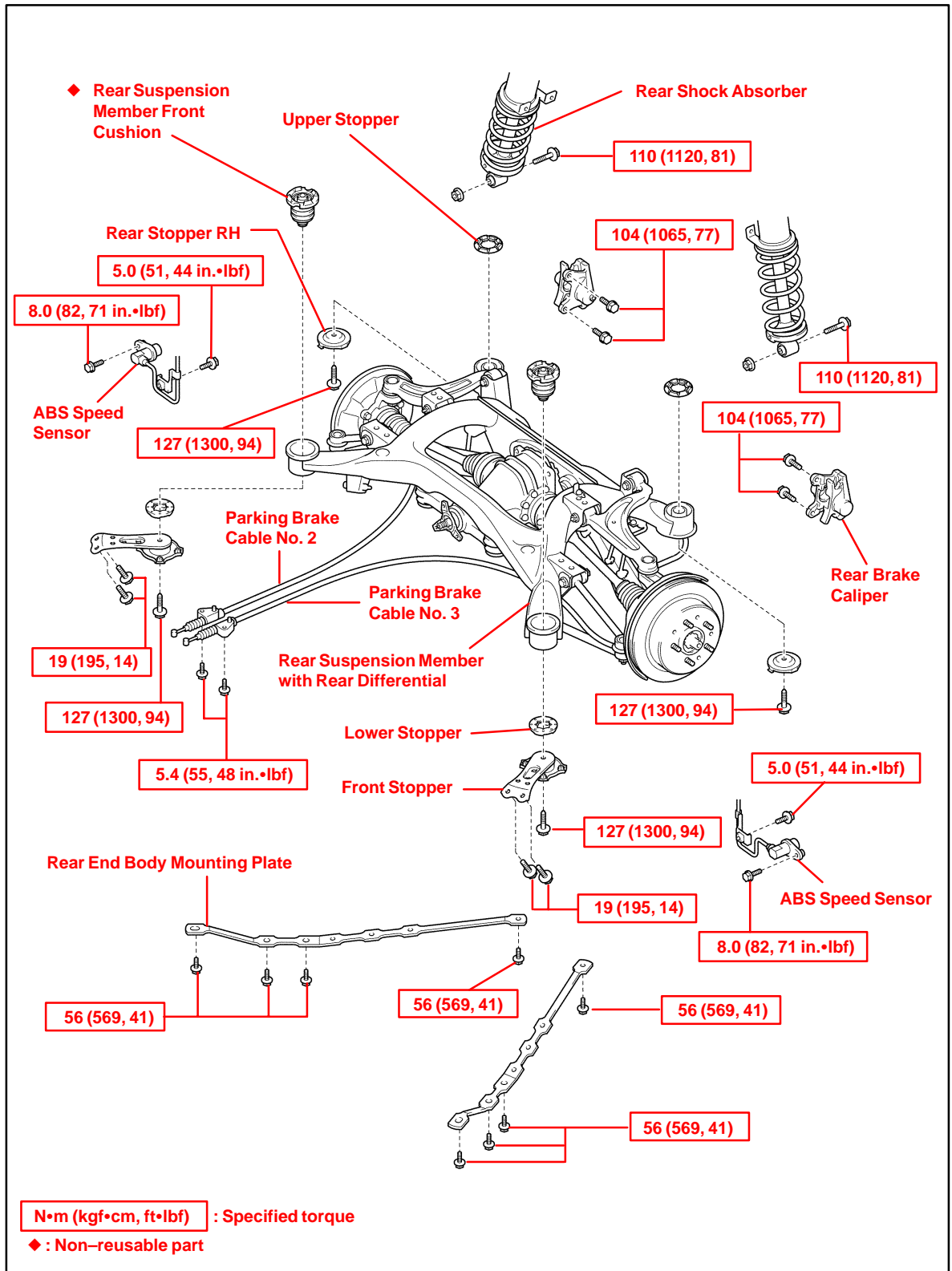

- Replacement Procedure**
1. Place on hoist with transmission in “N” position.
  2. Remove RH and LH rear wheels.
  3. Reinstall one lug nut on each wheel to retain brake rotors.
  4. Remove front floor center brace.  
Remove the 4 bolts and front floor center brace.
  5. Remove rear suspension member rear lower LH brace.  
Remove the 2 bolts and rear lower LH brace.
  6. Remove rear suspension member rear lower RH brace.  
Remove the 2 bolts and rear lower RH brace.

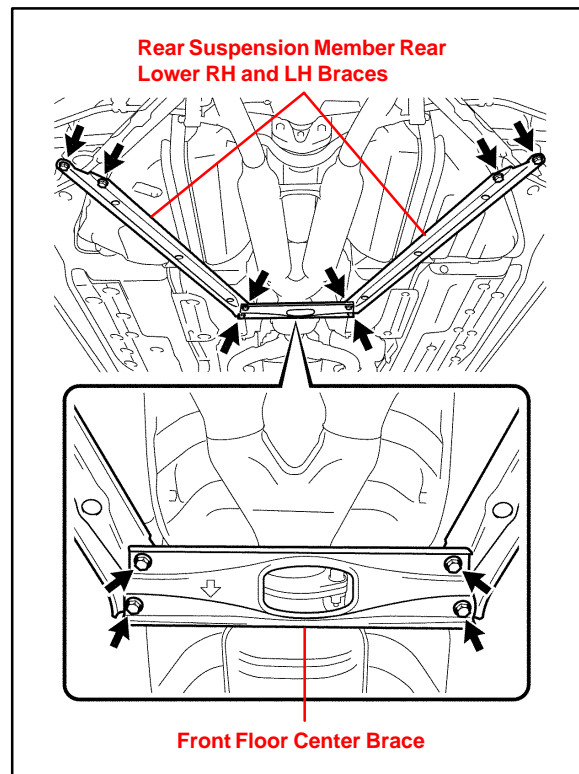

7. Remove front with center exhaust pipes.
  - A. Disconnect the 2 oxygen sensors.
  - B. Remove the 4 bolts, nuts and 2 gaskets, and disconnect the front with center exhaust pipes from the three-way catalyst.
  - C. Remove the 4 bolts, nuts and 2 gaskets, and disconnect the front with center exhaust pipes from the tailpipe.
  - D. Disconnect the 2 rings and remove the front with center exhaust pipes.

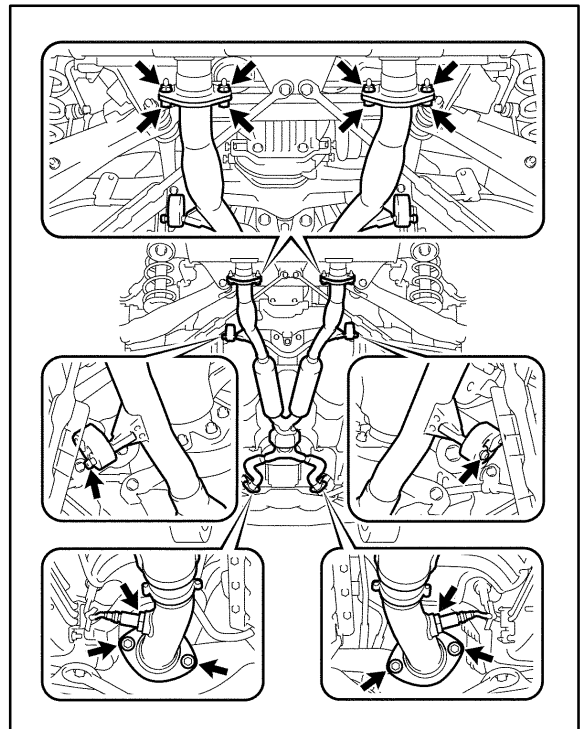

**Replacement Procedure**  
(Continued)

- 8. Remove front floor heat insulator No. 1.**  
Remove the 4 bolts and heat insulator No. 1.
  
- 9. Remove parking brake cable heat insulator.**  
Remove the 4 bolts and parking brake cable heat insulator.

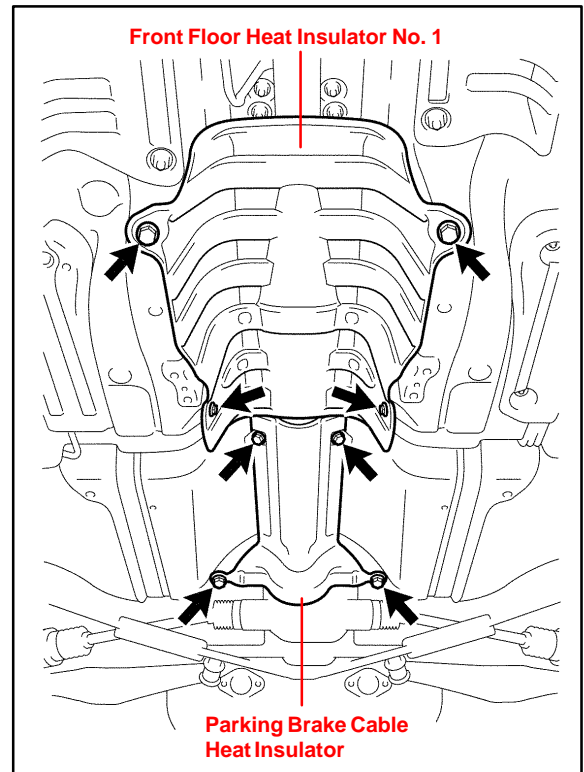

- 10. Remove propeller shaft.**
  - A. Using SST, loosen the adjusting nut until it can be turned by hand.
    - SST P/N: 09922-10010

**HINT:**  
Use 2 SSTs of the same type.

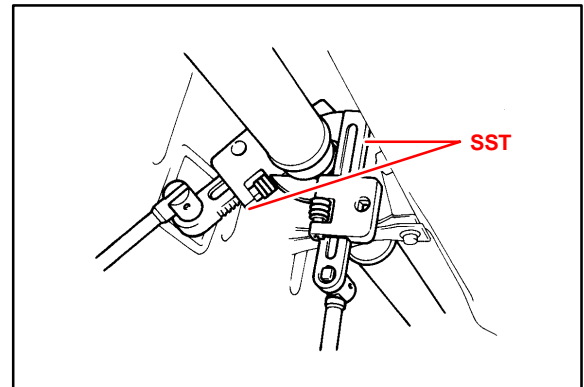

- B. Place matchmarks on the transmission companion flange and flexible coupling.
- C. Loosen the 3 bolts of the transmission side.

**NOTE:**  
The bolts should not be removed.

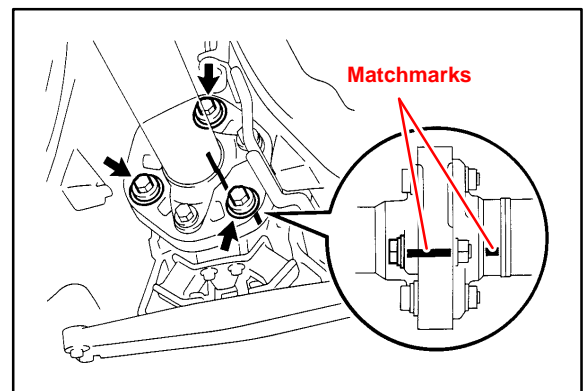

**Replacement Procedure**  
(Continued)

- D. Place matchmarks on the differential companion flange and flexible coupling.
- E. Loosen the 3 bolts of the differential side.

**NOTE:**

The bolts should not be removed.

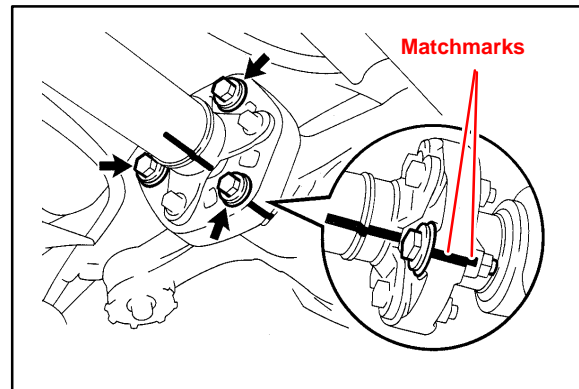

- F. Remove the loosened bolts and using a screwdriver, separate the flexible couplings from the transmission and differential.

**NOTE:**

Do not bring the screwdriver blade in direct contact with the flexible coupling's rubber part.

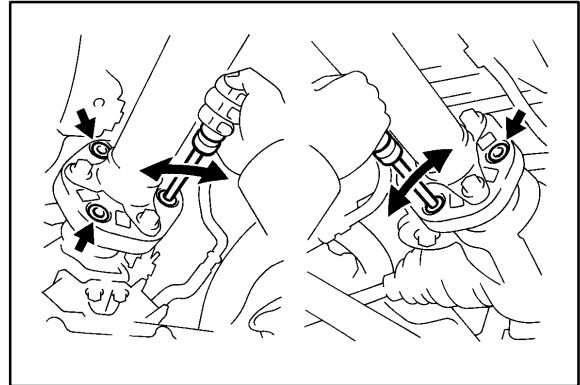

**HINT:**

If the flexible coupling cannot be easily separated by hand, insert a screwdriver into the bolt hole of the flexible coupling as shown in the illustration, then pry the coupling out.

- G. Remove the 2 center support bearing set bolts and adjusting washers.

Maximum joint angle: 5°

**NOTE:**

When removing the set bolts, support the center support bearing by hand so that the transmission, intermediate shaft, propeller shaft and differential remain in a straight line.

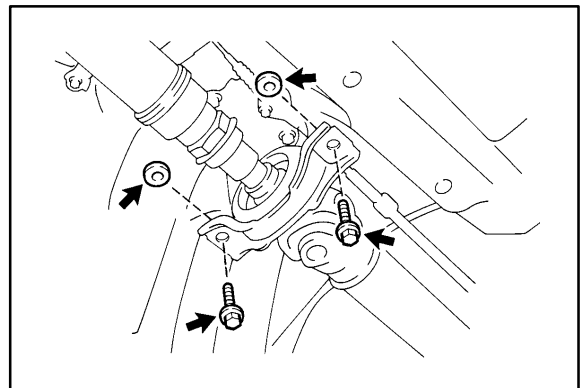

**HINT:**

Some vehicles are not equipped with an adjusting washer.

**Replacement Procedure**  
(Continued)

- H. Push the rear propeller shaft straight forward to compress the propeller shaft and pull out the propeller shaft from the centering pin of the differential.

**NOTE:**

Press the propeller shaft straight ahead to keep the transmission and intermediate shaft aligned straight.

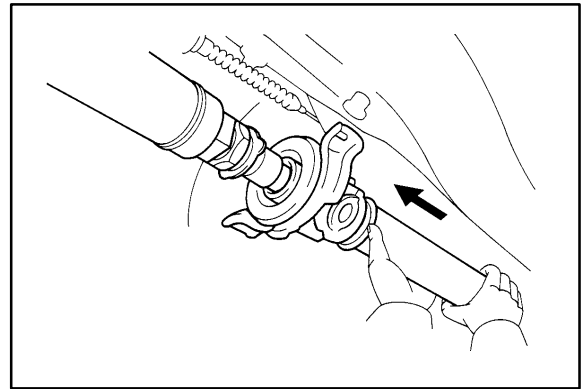

- I. Pull the propeller shaft toward the rear of the vehicle.

**NOTE:**

The intermediate shaft and propeller shaft should not be separated.

**11. Remove rear end body mounting plate LH.**

Remove the 4 bolts and end body mounting plate LH.

**12. Remove rear end body mounting plate RH.**

Remove the 4 bolts and end body mounting plate RH.

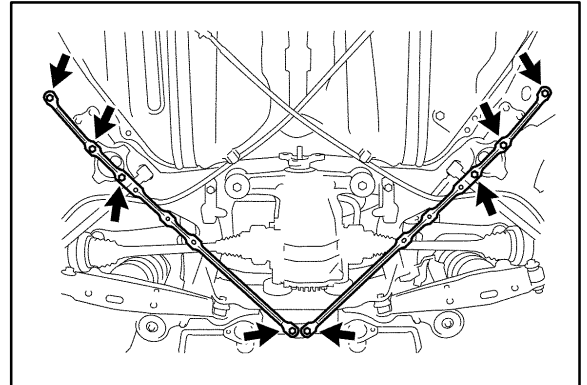

**Replacement Procedure**  
(Continued)

**13. Disconnect parking brake cable No. 2 and No. 3 from parking brake intermediate lever. (See illustration below.)**

- A. Remove the 2 bolts.
- B. Disconnect the parking brake cable No. 2 and No. 3 from the 2 clamps.
- C. Remove the 4 clamps.
- D. Disconnect the parking brake cable No. 2 and No. 3 from the parking brake intermediate lever.

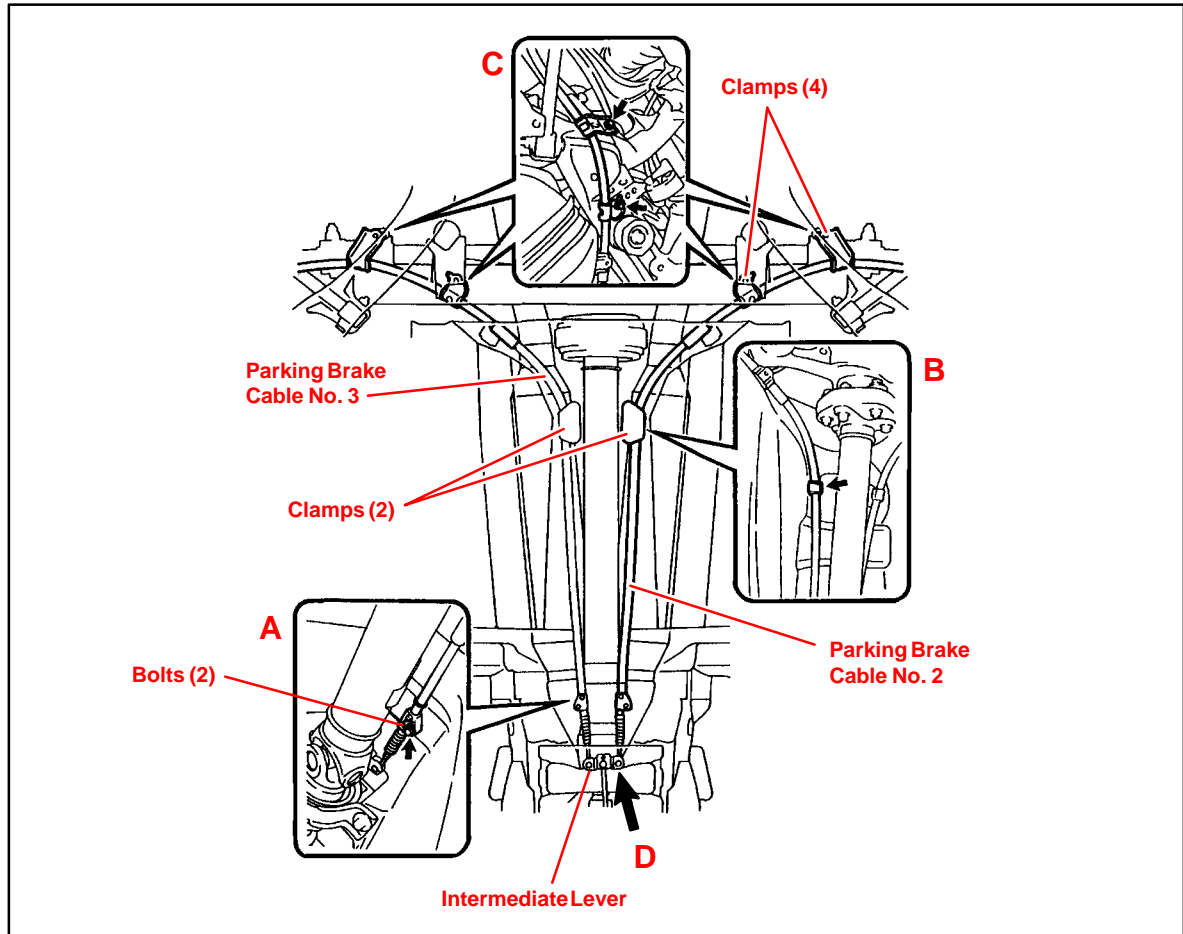

**14. Remove rear brake caliper LH from rear axle carrier.**

- A. Remove the 2 bolts and brake caliper LH.
- B. Support the brake caliper securely.

**15. Remove rear brake caliper RH from rear axle carrier.**

- A. Remove the 2 bolts and brake caliper RH.
- B. Support the brake caliper securely.

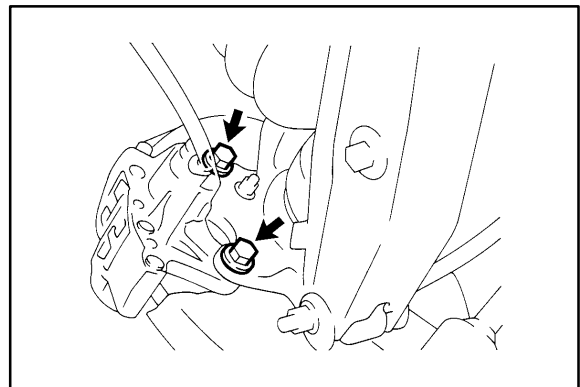



Replacement  
Procedure  
(Continued)

**16. Disconnect height control sensor connector and 2 clamps.**

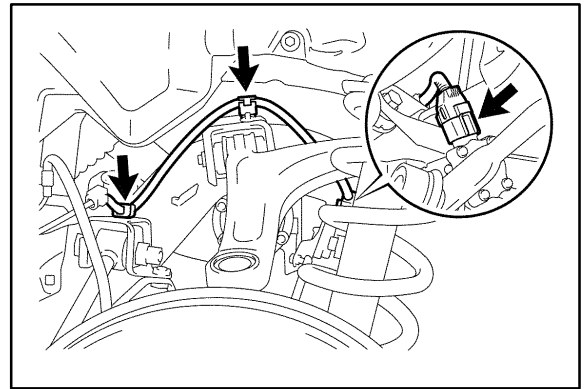

**17. Disconnect ABS speed sensor LH and wire harness clamp.**

- A. Remove the bolt and disconnect the ABS speed sensor LH.
- B. Remove the bolt and disconnect the ABS speed sensor wire harness clamp.

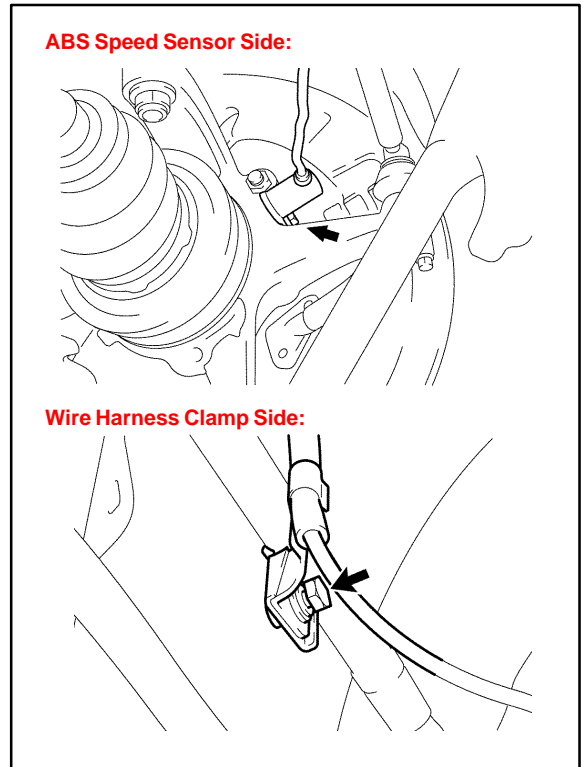

**18. Disconnect ABS speed sensor RH and wire harness clamp.**

- A. Remove the bolt and disconnect the ABS speed sensor RH.
- B. Remove the bolt and disconnect the ABS speed sensor wire harness clamp.

**19. Disconnect rear shock absorber LH from lower suspension arm.**

Remove the bolt and nut, and disconnect the shock absorber LH.

**NOTE:**  
When removing the bolt, stop the nut from rotating and loosen the bolt.

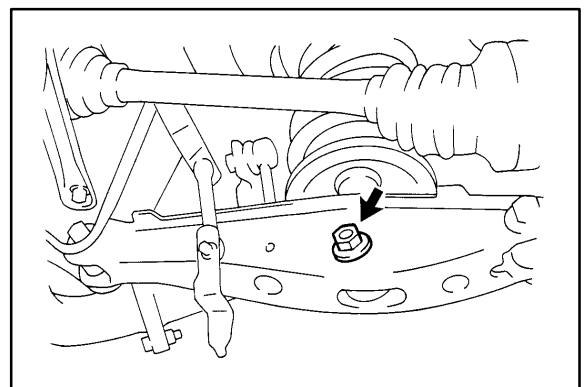

**20. Disconnect rear shock absorber RH from lower suspension arm.**

Remove the bolt and nut, and disconnect the shock absorber RH.

**NOTE:**  
When removing the bolt, stop the nut from rotating and loosen the bolt.

Replacement  
Procedure  
(Continued)

**21. Remove rear suspension member with rear differential and suspension.**

- A. Remove the 2 bolts from the front stopper LH (1).
- B. Remove the 2 bolts from the front stopper RH (2).
- C. Support the rear suspension member with a jack.
- D. Remove the 4 bolts (3), front stopper RH and LH (4), rear stopper RH and LH (5), and rear suspension member with the rear differential.
- E. Lower the rear suspension member with a jack.

**NOTE:**

Be careful not to damage the 2 clamps of the parking brake cable heat insulator.

- F. Remove the upper stopper RH and LH (6).
- G. Remove the lower stopper RH and LH (7).

**22. Locate rear suspension member front cushion.**

Mark the forward location on the sub-frame, LH and RH sides to facilitate locating the replacement rear suspension member front cushion.

**NOTE:**

Old cushion has an arrow that can be used as a guide when marking sub-frame.

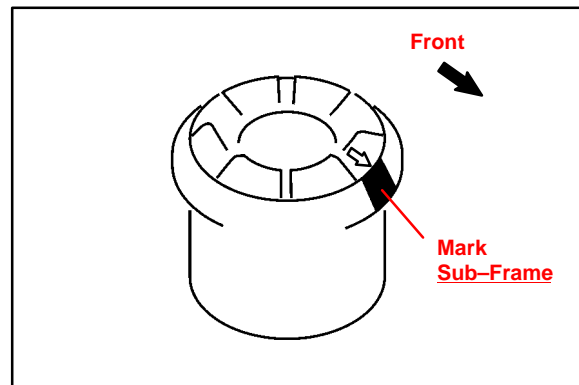
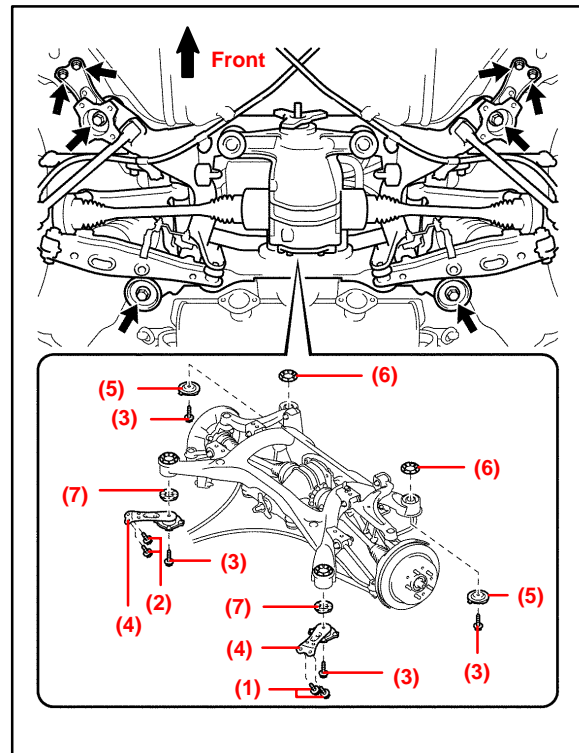

Replacement  
Procedure  
(Continued)

**23. Remove rear suspension member front cushion RH and LH.**

Using the following SSTs, remove the front cushion RH and LH.

- 09608-06041
- 09950-00020
- 09950-40011 (09951-04020, 09953-04020, 09957-04010)
- 09950-50013 (09952-05010, 09954-05080, 09955-05040)
- 09950-60010 (09951-00340)

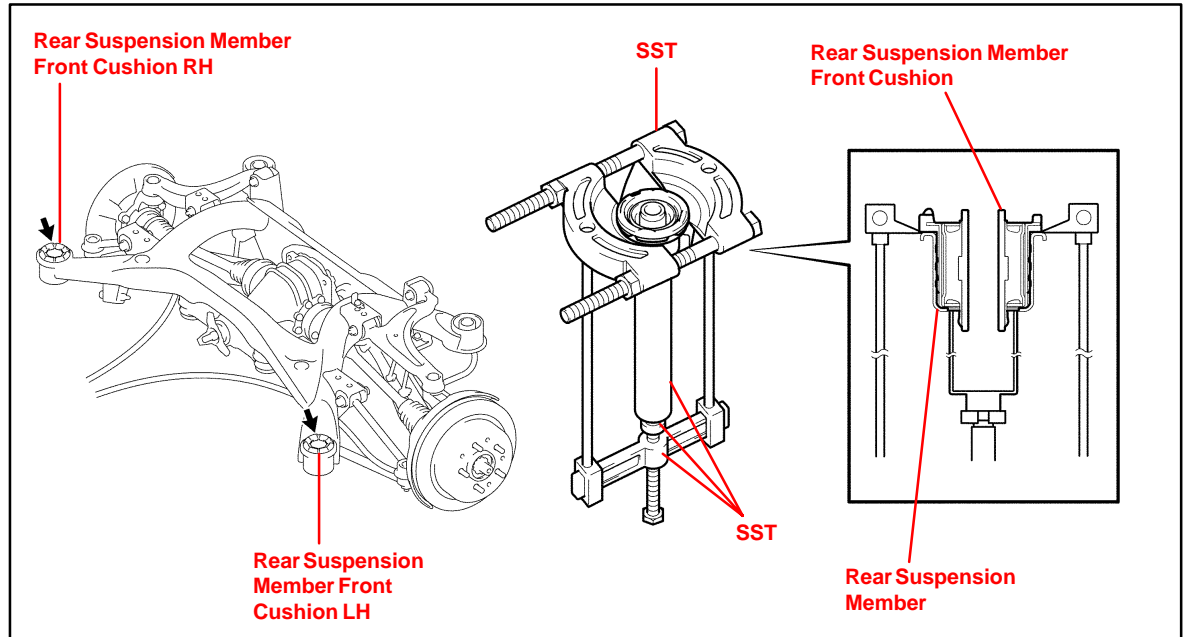

**24. Touch up paint damage.**

Touch up any paint damage that may occur to sub-frame.

**25. Install the rear suspension member front cushion RH and LH.**

Using the following SSTs, install the 2 new cushions RH and LH.

- 09950-40011  
(09951-04020, 09952-04010, 09954-04010, 09955-04051, 09957-04010, 09958-04011)
- 09950-60020 (09951-00710)

**NOTE:**

- Install the cushion so that the indentations on the top of the cushion are 90° from the front of the vehicle (marked on sub-frame in step 22) as shown at right.
- Install the cushion so that the seat of the cushion just fits onto the rear suspension member. Do not press in further or the SST could be damaged.

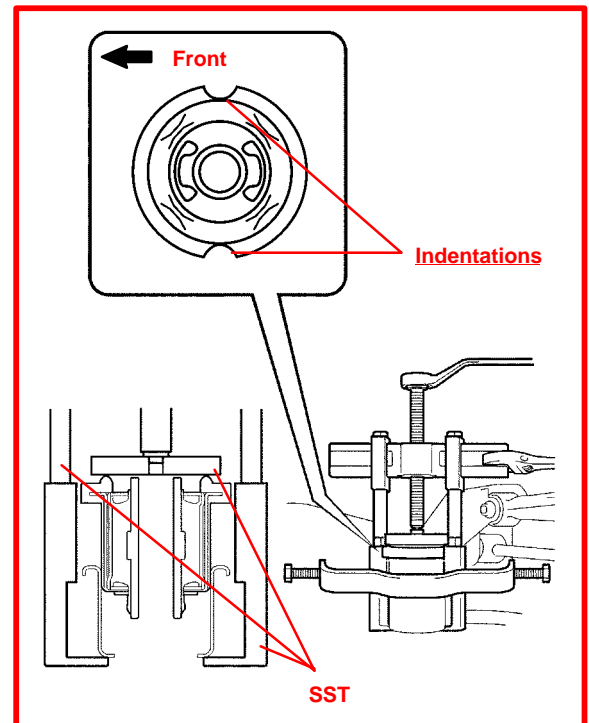

Replacement  
Procedure  
(Continued)

26. Install the rear suspension member with rear differential and suspension.

- A. Install the lower stopper RH and LH (1).
- B. Install the upper stopper RH and LH (2).
- C. Jack up the rear suspension member with the rear differential and suspension.

**NOTE:**

Be careful not to damage the 2 clamps of the parking brake cable heat insulator.

- D. Install the rear suspension member with the rear differential, front stopper RH and LH (3), rear stopper RH and LH (4) and with the 4 bolts (5).

Torque: 127 N•m (1,300 kgf•cm, 94 ft•lbf)

**NOTE:**

Make sure that the rear suspension member rear stopper RH and LH (4) part A is installed within the area shown in the illustration.

- E. Install the 2 front stopper LH set bolts (6).

Torque: 19 N•m (195 kgf•cm, 14 ft•lbf)

- F. Install the 2 front stopper RH set bolts (7).

Torque: 19 N•m (195 kgf•cm, 14 ft•lbf)

27. Connect rear shock absorber LH to lower suspension arm.

Connect the shock absorber LH with the bolt and nut.

Torque: 110 N•m (1,120 kgf•cm, 81 ft•lbf)

**NOTE:**

When installing the bolt, stop the nut from rotating and install the bolt.

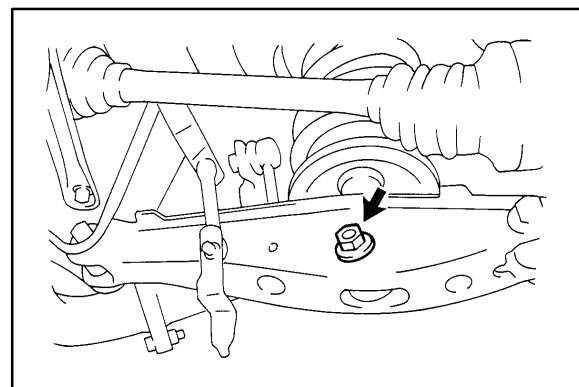
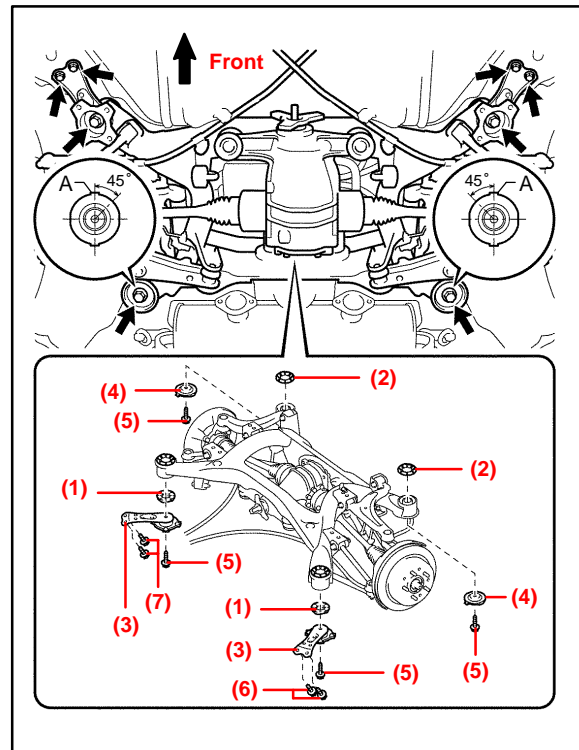

**Replacement  
Procedure**  
(Continued)

**28. Connect rear shock absorber RH to lower suspension arm.**

Connect the shock absorber RH with the bolt and nut.

**Torque: 110 N•m (1,120 kgf•cm, 81 ft•lbf)**

**NOTE:**

When installing the bolt, stop the nut from rotating and install the bolt.

**29. Connect ABS speed sensor LH and wire harness clamp.**

A. Connect the ABS speed sensor wire harness clamp with the bolt.

**Torque: 5.0 N•m (51 kgf•cm, 44 in.•lbf)**

B. Connect the ABS speed sensor with the bolt.

**Torque: 8.0 N•m (82 kgf•cm, 71 in.•lbf)**

**30. Connect ABS speed sensor RH and wire harness.**

A. Connect the ABS speed sensor wire harness clamp with the bolt.

**Torque: 5.0 N•m (51 kgf•cm, 44 in.•lbf)**

B. Connect the ABS speed sensor with the bolt.

**Torque: 8.0 N•m (82 kgf•cm, 71 in.•lbf)**

**ABS Speed Sensor Side:**

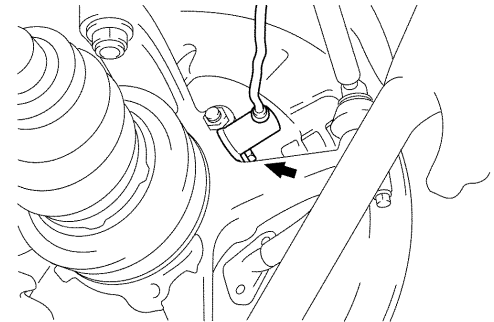

**Wire Harness Clamp Side:**

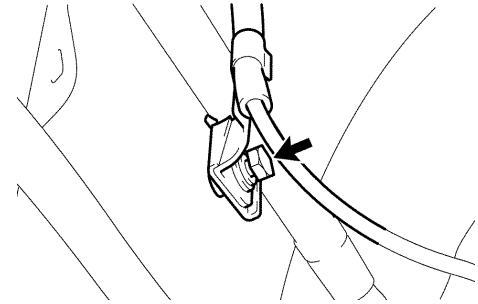

**31. Connect height control sensor connector and 2 clamps.**

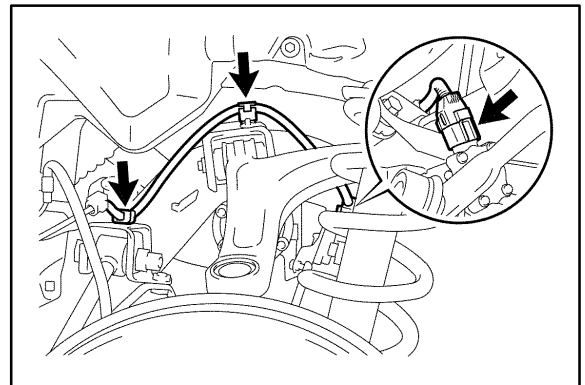

Replacement Procedure  
(Continued)

**32. Install rear brake caliper LH to rear axle carrier.**

Install the brake caliper LH with the 2 bolts.

**Torque: 104 N•m (1,065 kgf•cm, 77 ft•lbf)**

**33. Install rear brake caliper RH to rear axle carrier.**

Install the brake caliper RH with the 2 bolts.

**Torque: 104 N•m (1,065 kgf•cm, 77 ft•lbf)**

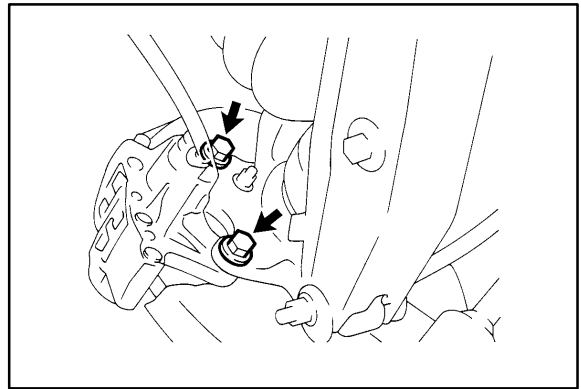

**34. Connect parking brake cable No. 2 and No. 3 to parking brake intermediate lever. (See illustration below.)**

- A. Connect the parking brake cable No. 2 and No. 3 to the parking brake intermediate lever.
- B. Connect the parking brake cable No. 2 and No. 3 to the 2 clamps.
- C. Reinstall the 4 clamps.
- D. Install the parking brake cable No. 2 and No. 3 with the 2 bolts.

**Torque: 5.4 N•m (55 kgf•cm, 48 in.•lbf)**

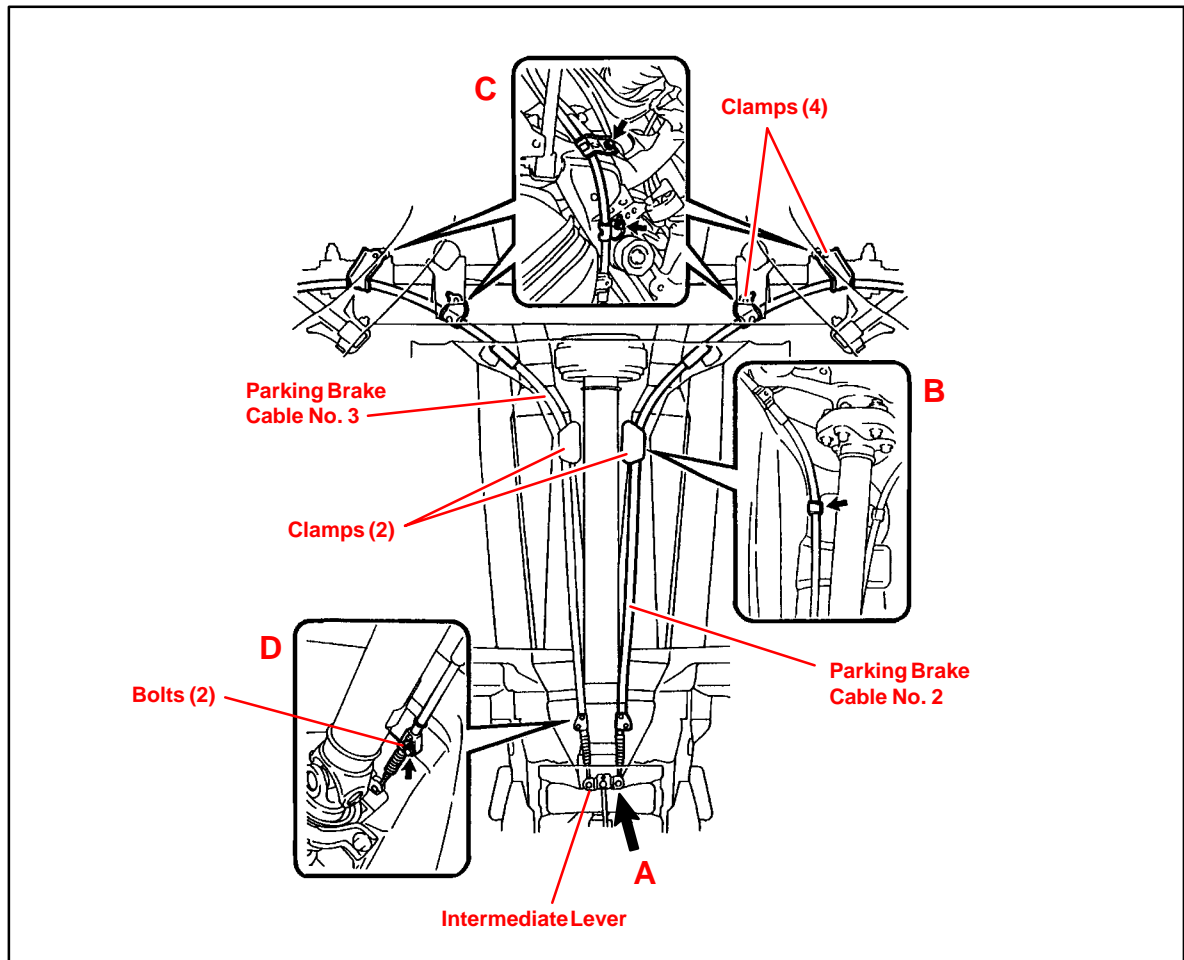

**Replacement Procedure**  
(Continued)

**35. Install rear end body mounting plate LH.**

Install the end body mounting plate LH with the 4 bolts.

**Torque: 56 N•m (569 kgf•cm, 41 ft•lbf)**

**36. Install rear end body mounting plate RH.**

Install the end body mounting plate RH with the 4 bolts.

**Torque: 56 N•m (569 kgf•cm, 41 ft•lbf)**

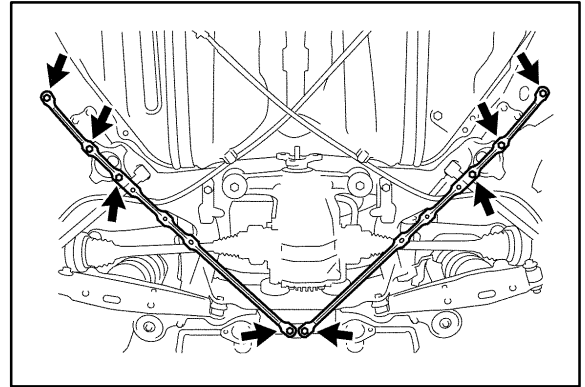

**37. Install propeller shaft.**

- A. Apply grease to the flexible coupling centering bushings.

**Grease: Molybdenum disulphide lithium base, NLGI No. 2**

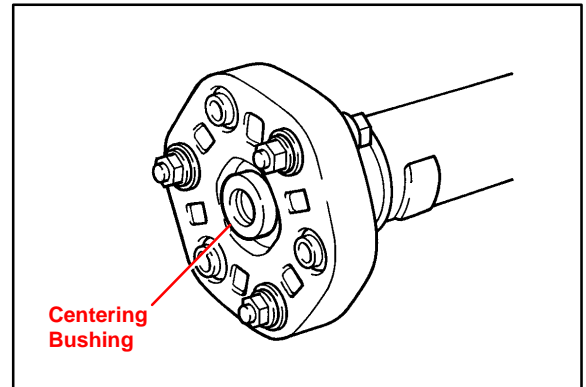

- B. Install the propeller shaft from the vehicle's rear and connect the transmission and differential.

**NOTE:**

Support the center support bearing by hand so that the transmission, intermediate shaft, propeller shaft and differential remain in a straight line.

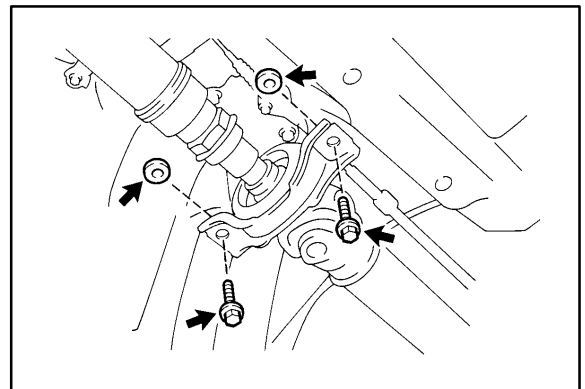

- C. Temporarily install the 2 center support bearing set bolts with the adjusting washers.

**NOTE:**

Use the original adjusting washers which were removed from the vehicle. The propeller shaft No. 2 and No. 3 joint angle needs to be checked if new or different adjusting washers from the original are installed.



**Replacement Procedure**  
(Continued)

- D. Align the matchmarks and connect the propeller shaft to the transmission/differential.
- E. Install and torque the 6 bolts, washers and nuts.

**Torque: 79 N•m (805 kgf•cm, 58 ft•lbf)**

**NOTE:**

The bolts should be installed from the propeller shaft side.

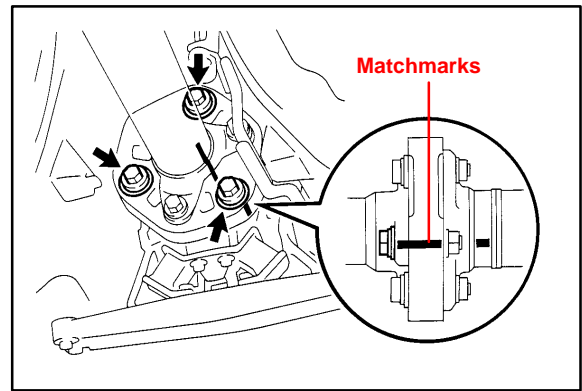

- F. Torque the 2 center support bearing set bolts.

**Torque: 37 N•m (375 kgf•cm, 27 ft•lbf)**

Adjust the center support bearing to keep the intervals as shown with the vehicle in the unladen condition.

Under the same condition, check if the center line of the center support bearing is at right angles to the shaft axial direction.

- G. Using the SST, tighten the adjusting nut.

- SST: 09922-10010

**Torque: 50 N•m (515 kgf•cm, 37 ft•lbf)**

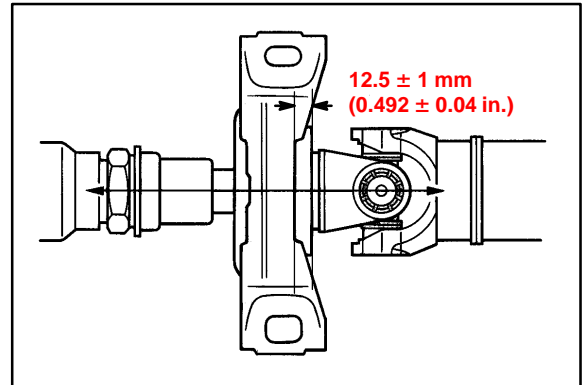

**HINT:**

Use a torque wrench with a fulcrum length of 34.5 cm (13.6 in.).

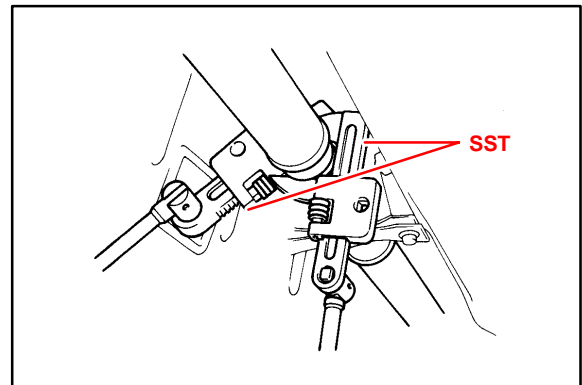

**38. Inspect propeller shaft No. 2 and No. 3 joint angle.**

**HINT:**

The propeller shaft angle needs to be checked if new or different adjusting washers from the original are installed. (See Pub. No. RM844U2, page 30-10.)



**Replacement Procedure**  
(Continued)

**39. Install parking brake cable heat insulator.**

Install the parking brake cable heat insulator with the 4 bolts.

**Torque: 5.4 N•m (55 kgf•cm, 48 in.•lbf)**

**40. Install front floor heat insulator No. 1.**

Install the floor heat insulator No. 1 with the 4 bolts.

**Torque: 5.4 N•m (55 kgf•cm, 48 in.•lbf)**

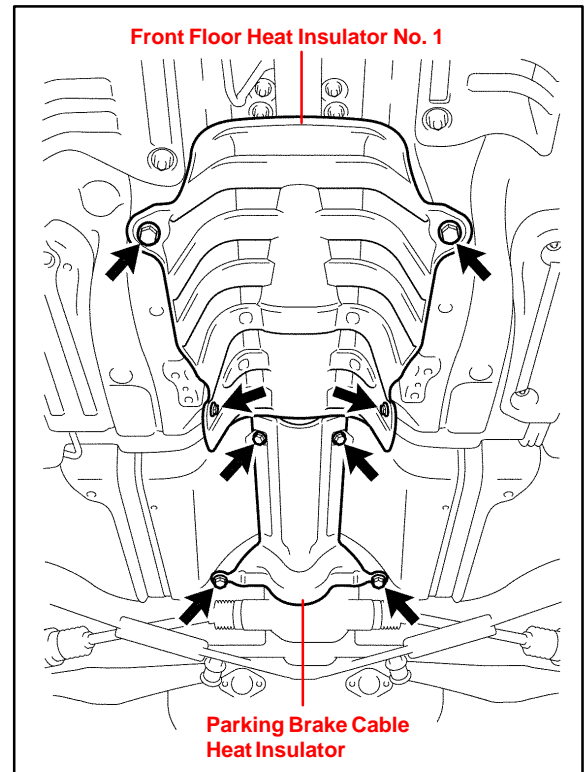

**41. Install front with center exhaust pipes.**

- A. Install the front with center exhaust pipes to the 2 rings.
- B. Install 2 new gaskets, and connect the front with center exhaust pipes to the tailpipe with the 4 bolts and nuts.

**Torque: 43 N•m (440 kgf•cm, 32 ft•lbf)**

- C. Install 2 new gaskets, and connect the front with center exhaust pipes to the three-way catalyst with the 4 bolts and nuts.

**Torque: 43 N•m (440 kgf•cm, 32 ft•lbf)**

- D. Connect the 2 oxygen sensors.

**Torque: 44 N•m (450 kgf•cm, 32 ft•lbf)**

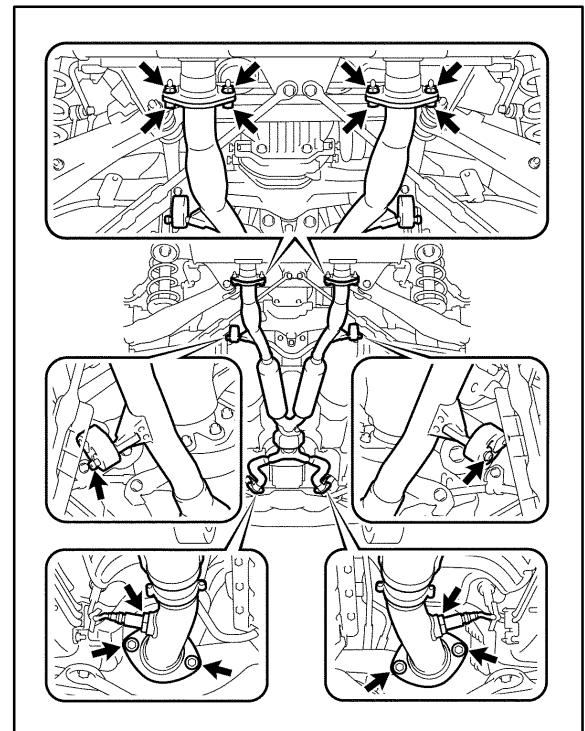

**NOTE:**

- Before installing the oxygen sensor, twist the sensor wire counterclockwise 3 and 1/2 turns.
- After installing oxygen sensor, check that the sensor wire is not twisted. If it is twisted, remove the oxygen sensor and install it again.

**Replacement Procedure**  
(Continued)**42. Install rear suspension member rear lower LH brace.**

Install the rear lower LH brace with the 2 bolts.

**Torque: 23 N•m (235 kgf•cm, 17 ft•lbf)**

**43. Install rear suspension member rear lower RH brace.**

Install the rear lower RH brace with the 2 bolts.

**Torque: 23 N•m (235 kgf•cm, 17 ft•lbf)**

**44. Install front floor center brace.**

Install the front floor center brace with the 4 bolts.

**Torque: 20 N•m (204 kgf•cm, 15 ft•lbf)**

**45. Install RH and LH rear wheels.**

**Torque: 103 N•m (1,050 kgf•cm, 76 ft•lbf)**

**46. Check ABS speed sensor signal.**

See Pub. No. RM844U1, page 05–233.

**47. Check for exhaust gas leak.**