

## OVERHAUL

### HINT:

- Installation is in the reverse order of the removal. But, the installation indicated only when it has a point.
- See the components' drawing of rear seat in page 72-7.

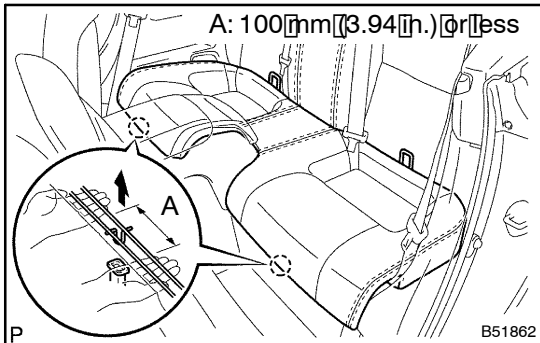

### 1. REMOVE REAR SEAT CUSHION ASSY

- (a) Pull up the front portion of the seat cushion assembly, then remove it.

#### NOTICE:

In the case, hold the base of the clip up to prevent the cushion frame from being distorted.

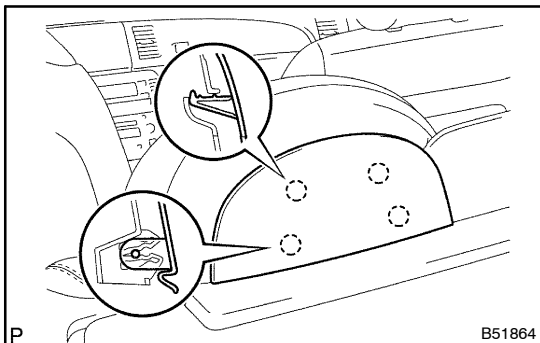

### 2. REMOVE REAR SEAT HEADREST PLATE COVER

- (a) Using a screwdriver, remove the 2 rear seat headrest plate covers.

#### HINT:

Tape the screwdriver tip before use.

- (b) Employ the same manner described above to the other side.

### 3. REMOVE WIND DEFLECTOR BOARD ASSY

- (a) Remove the 4 bolts and the wind deflector board assembly.

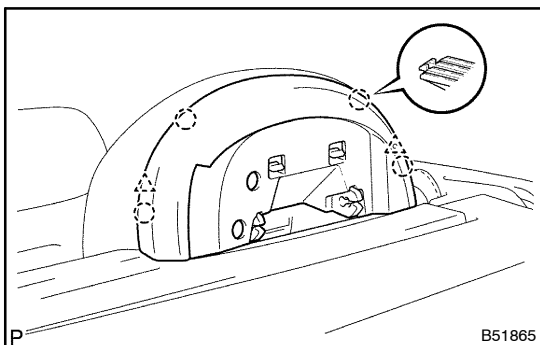

### 4. REMOVE REAR SEAT HEADREST PLATE

- (a) Using a screwdriver, remove the 2 rear seat headrest plates.

#### HINT:

Tape the screwdriver tip before use.

- (b) Employ the same manner described above to the other side.

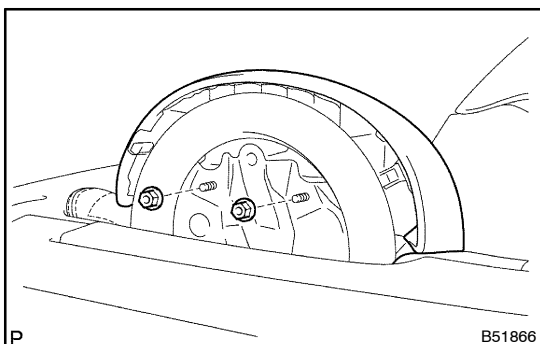

### 5. REMOVE REAR SEAT HEADREST ASSY

- (a) Remove the 4 nuts and the 2 rear seat headrest assemblies.
- (b) Employ the same manner described above to the other side.

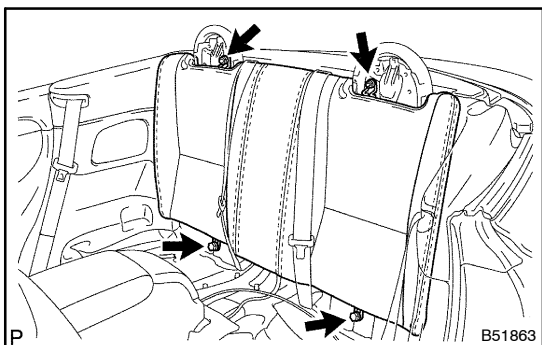

## 6. REMOVE REAR SEAT BACK ASSY

- (a) Remove the 2 nuts, 2 bolts and the rear seat back assembly.

## 7. REMOVE BENCH TYPE REAR SEAT CUSHION COVER

- (a) Remove the hog rings and rear seat cushion cover.

## 8. REMOVE BENCH TYPE REAR SEAT BACK COVER

- (a) Remove the hog rings and rear seat back cover.

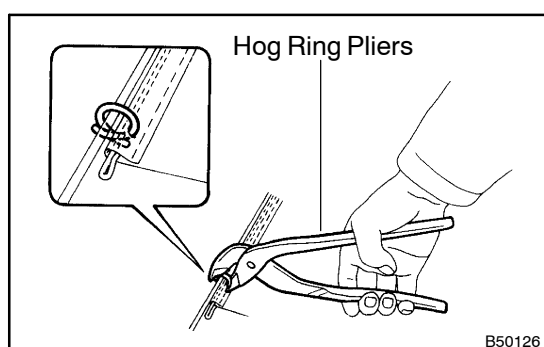

## 9. INSTALL BENCH TYPE REAR SEAT BACK COVER

- (a) Install the rear seat back cover to the rear seat back pad with new hog rings.

### HINT:

- Do not damage the seat back cover nor make it dirty.
- When installing the hog rings, take care to prevent wrinkles as much as possible.

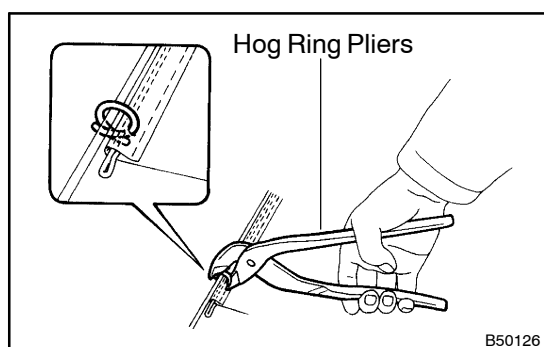

## 10. INSTALL BENCH TYPE REAR SEAT CUSHION COVER

- (a) Install the rear seat cushion cover to the rear seat cushion pad with new hog rings.

### HINT:

- Do not damage the seat cushion cover nor make it dirty.
- When installing the hog rings, take care to prevent wrinkles as much as possible.

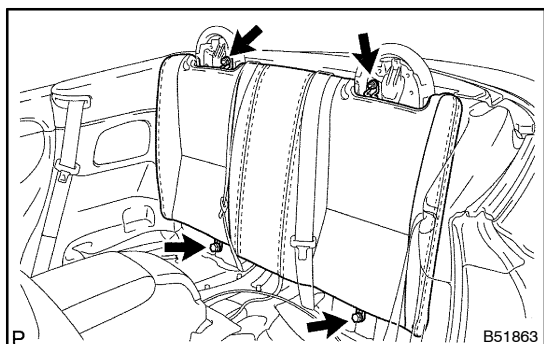

## 11. INSTALL REAR SEAT BACK ASSY

- (a) Install the rear seat back assembly with the 2 nuts and 2 bolts.

**Torque: 18 N·m (184 kgf·cm, 13 ft·lbf)**

**12. INSTALL REAR SEAT HEADREST ASSY****Torque: 5.0 N·m (51 kgf·cm, 44 in·lbf)**