

## ENGINE CONTROL SYSTEM

### 1. General

#### ► System Comparison List ◀

System	Outline	SC430	LS430
EFI (Electronic Fuel Injection) (For details, <a href="#">see page EG-46</a> )	<ul style="list-style-type: none"> <li>● An L-type EFI system directly detects the intake air mass with a hot wire type air flow meter.</li> <li>● The fuel injection system is a sequential multiport fuel injection system.</li> </ul>	○	○
ESA ( Electronic Spark Advance ) (For details, <a href="#">see page EG-48</a> )	<ul style="list-style-type: none"> <li>● Ignition timing is determined by the engine ECU based on signals from various sensors. Corrects ignition timing in response to engine knocking.</li> <li>● 2 knock sensors are used to improve knock detection.</li> <li>● The torque control correction during gear shifting has been used to minimize the shift shock.</li> </ul>	○	○
VVT-i ( Variable Valve Timing-intelligent ) (For details, <a href="#">see page EG-49</a> )	Controls the intake camshaft to an optimal valve timing in accordance with the engine condition.	○	○
ETCS-i ( Electronic Throttle Control System-intelligent ) (For details, <a href="#">see page EG-54</a> )	Optimally controls the throttle valve opening in accordance with the amount of accelerator pedal effort and the condition of the engine and the vehicle.	○	○
	Torque activated power train control has been adopted.	○	○
ACIS ( Acoustic Control Induction System ) (For details, <a href="#">see page EG-57</a> )	The intake air passage are switched according to the engine speed and throttle valve angle to increase performance in all speed ranges.	○	○
Cooling Fan Control (For details, <a href="#">see page EG-60</a> )	An electric cooling fan system has been adopted. The engine ECU steplessly controls the speed of the fans in accordance with the engine coolant temperature, vehicle speed, engine speed, and air conditioner operating conditions. As a result, the cooling performance has been improved.	○	○
Fuel Pump Control (For details, <a href="#">see page EG-61</a> )	The fuel pump speed is controlled by the fuel pump relay and the fuel pump resistor.	○	○
	A fuel cut control is adopted to stop the fuel pump when the airbag is deployed at the front or side collision.	○	○
Oxygen Sensor Heater Control	Maintains the temperature of the oxygen sensor at an appropriate level to increase accuracy of detection of the oxygen concentration in the exhaust gas.	○	○
Air Conditioner Cut-Off Control	By controlling the air conditioner compressor ON or OFF in accordance with the engine condition, drivability is maintained.	○	○
Evaporative Emission Control	The engine ECU controls the purge flow of evaporative emissions (HC) in the charcoal canister in accordance with engine conditions.	○	○
Engine Immobiliser (For details, <a href="#">see page BE-107</a> )	Prohibits fuel delivery and ignition if an attempt is made to start the engine with an invalid ignition key.	○	○
Function to communicate with multiplex communication system (For details, <a href="#">see page BE-2</a> )	Communicates with the meter ECU, A/C ECU, etc., on the body side, to input/output necessary signals.	○	○
Diagnosis (For details, <a href="#">see page EG-62</a> )	When the engine ECU detects a malfunction, the engine ECU makes a diagnosis and memorizes the failed section.	○	○
	To increase the speed for processing the signals, the 32-bit CPU of the engine ECU has been adopted.	○	○
Fail-Safe (For details, <a href="#">see page EG-65</a> )	When the engine ECU detects a malfunction, the engine ECU stops or controls the engine according to the data already stored in the memory.	○	○

**2. Construction**

The configuration of the engine control system in the 3UZ-FE engine of the SC430 is as shown in the following chart.

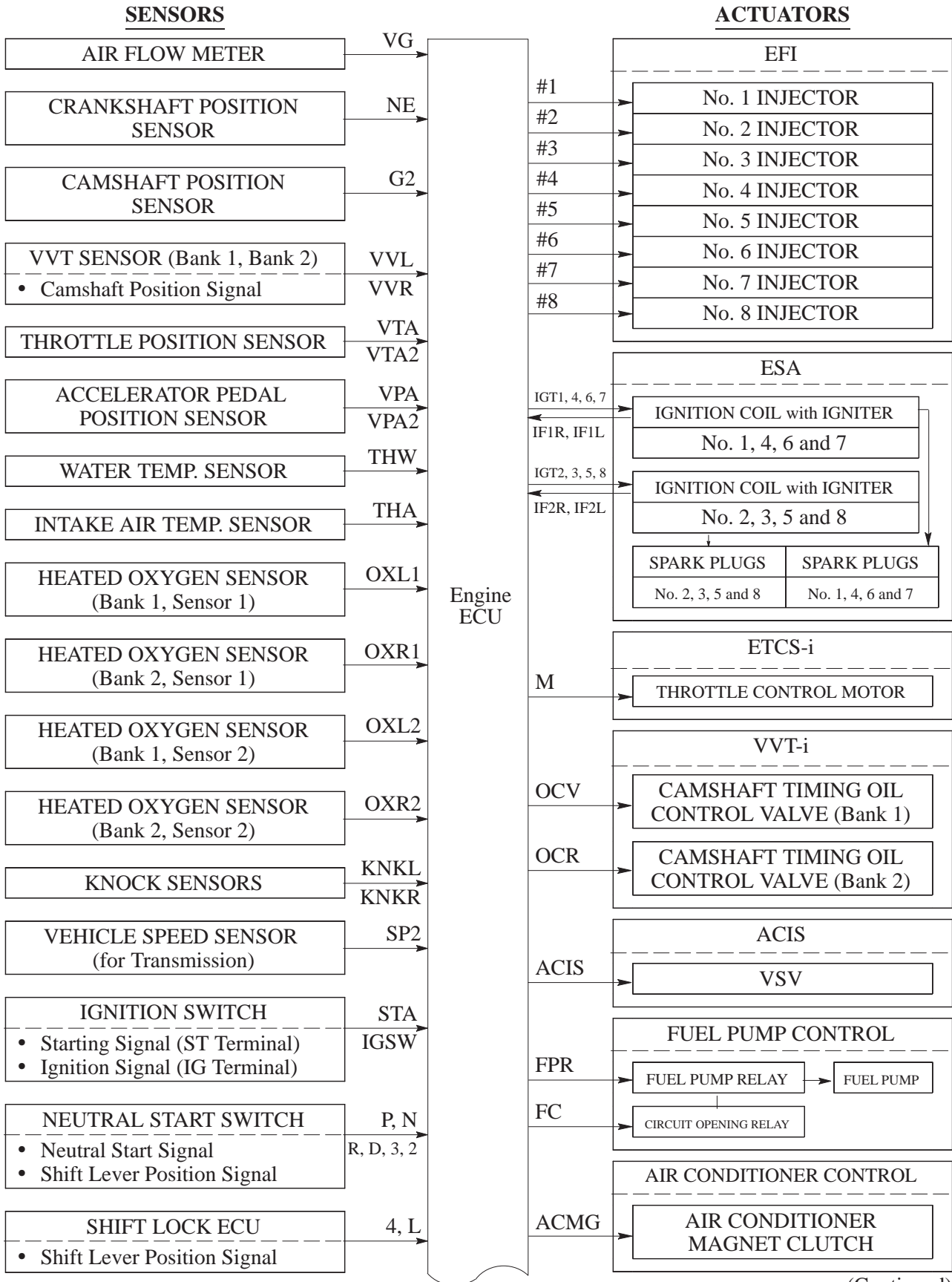

(Continued)

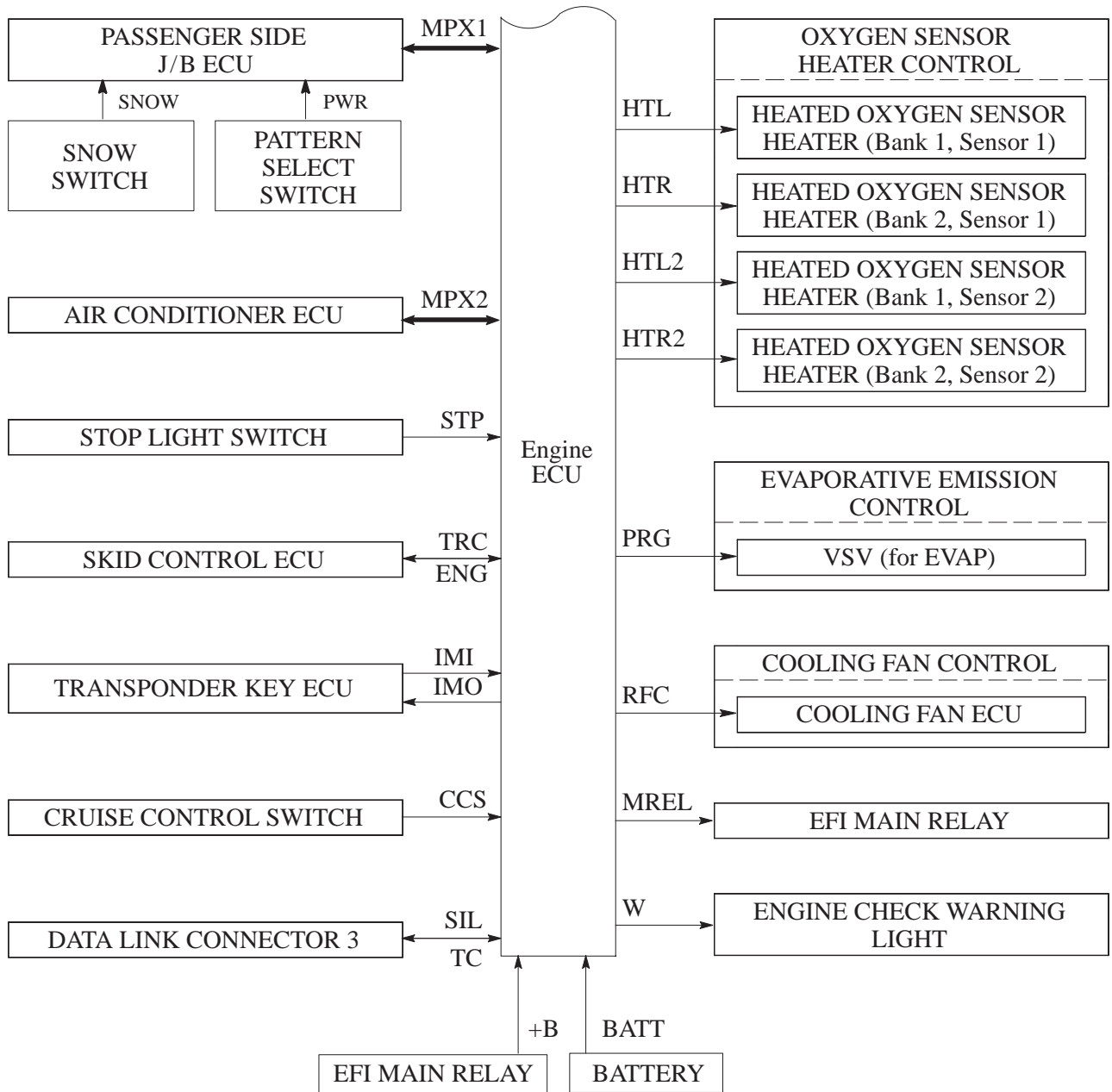

3. Engine Control System Diagram

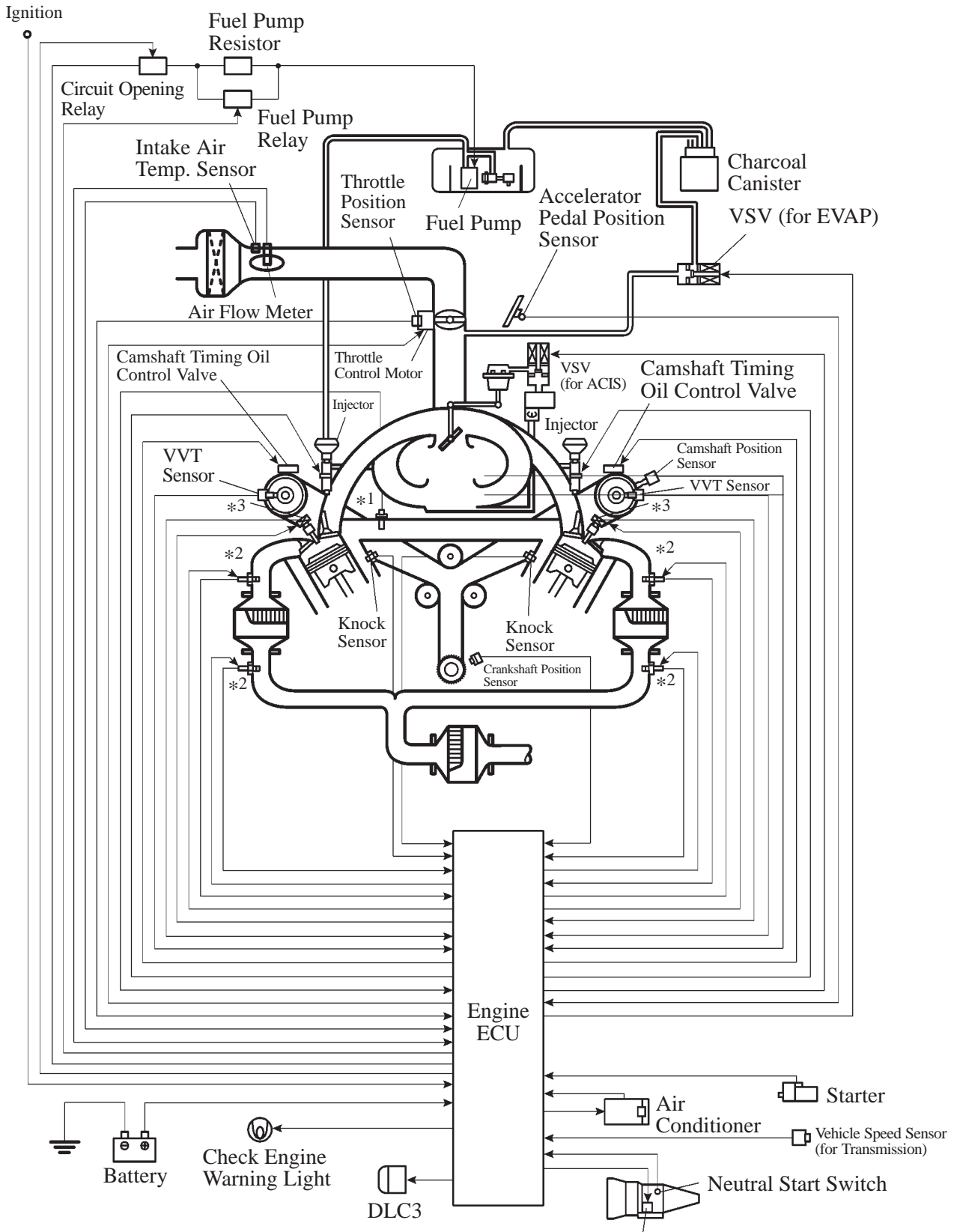

- \*1: Water Temp. Sensor
- \*2: Heated Oxygen Sensor
- \*3: Ignition Coil (with Igniter)

Electronic Controlled  
Transmission  
Solenoid Valves

4. Layout of Main Component

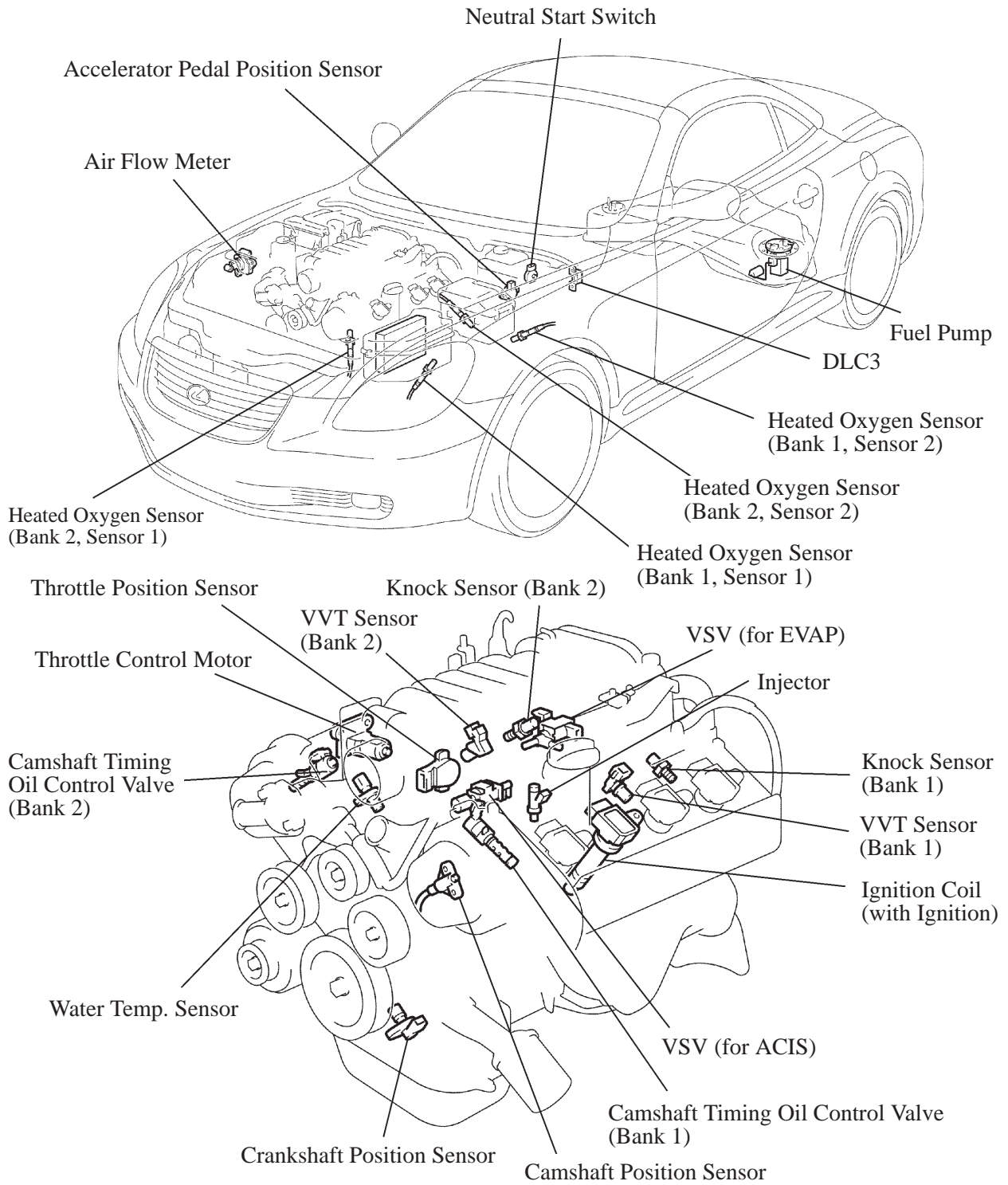

### 5. Main Components of Engine Control System

#### General

The following table compares the main components.

: Changed

Engine Type Component	3UZ-FE		1UZ-FE	
	Outline	Quantity	Outline	Quantity
Engine ECU	32-bit CPU	1	16-bit CPU	1
Air Flow Meter	Hot-wire Type	1	←	
Crankshaft Position Sensor (Rotor Teeth)	Pick-up Coil Type (36-2)	1	←	
Camshaft Position Sensor (Rotor Teeth)	Pick-up Coil Type (1)	1	←	
VVT Sensor (Rotor Teeth)	Pick-up Coil Type (3)	2	←	
Throttle Position Sensor	Linear Type	1*	←	
Accelerator Pedal Position Sensor	Linear Type	1*	←	
Knock Sensor	Built-in Piezoelectric Type	2	←	
Oxygen Sensor (Bank 1, Sensor 1) (Bank 1, Sensor 2) (Bank 2, Sensor 1) (Bank 2, Sensor 2)	with Heater Type	4	←	
Injector	4-hole Type (with Air Assist)	8	←	

\*: 2 Output Type

#### Engine ECU

– Changes –

- The 32-bit CPU of the engine ECU has been changed from the 16-bit CPU to increase the speed for processing the signals.

#### Service Tip

The length of time to clear the DTC via the battery terminal has been changed from the previous 10 seconds to 1 minute.

- The engine ECU is installed in the engine ECU box in the engine compartment. As a result, the wiring harness has been shortened, thus realizing weight reduction.
- Utilizing the vacuum that is generated by the cooling fan, air flow is introduced through the engine ECU box to restrain the increase in the temperature in the engine ECU box.

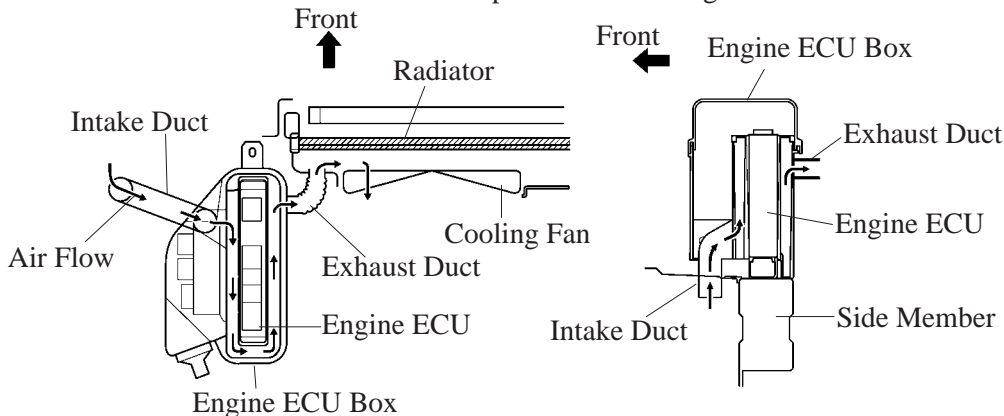

### Air Flow Meter

- This air flow meter, which is a plug-in type, allows a portion of the intake air to flow through the detection area. By directly measuring the mass and the flow rate of the intake air, the detection precision has been improved and the intake air resistance has been reduced.
- This air flow meter has a built-in intake air temperature sensor.

#### – Changes –

It has been made more compact and lightweight than on the previous air flow meter.

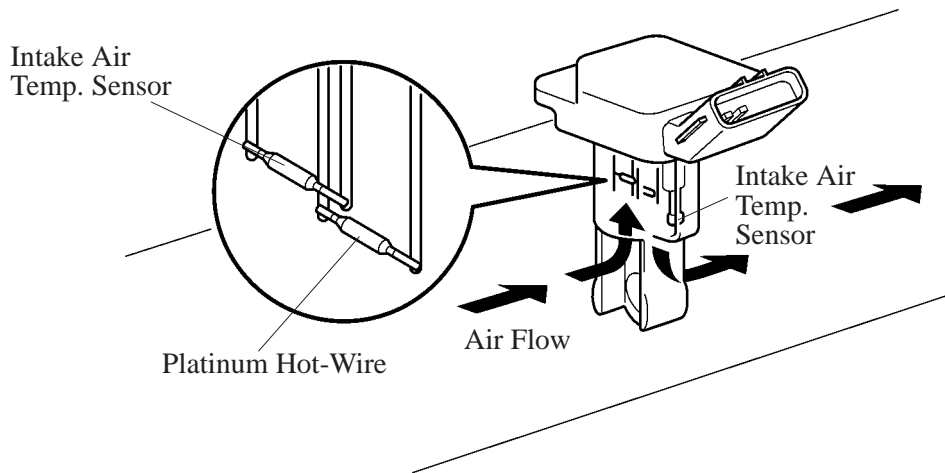

199EG35

### Crankshaft Position Sensor

The timing rotor of the crankshaft consists of 34 teeth, with 2 teeth missing. The crankshaft position sensor outputs the crankshaft rotation signals every  $10^\circ$ , and the missing teeth are used to determine the top-dead-center.

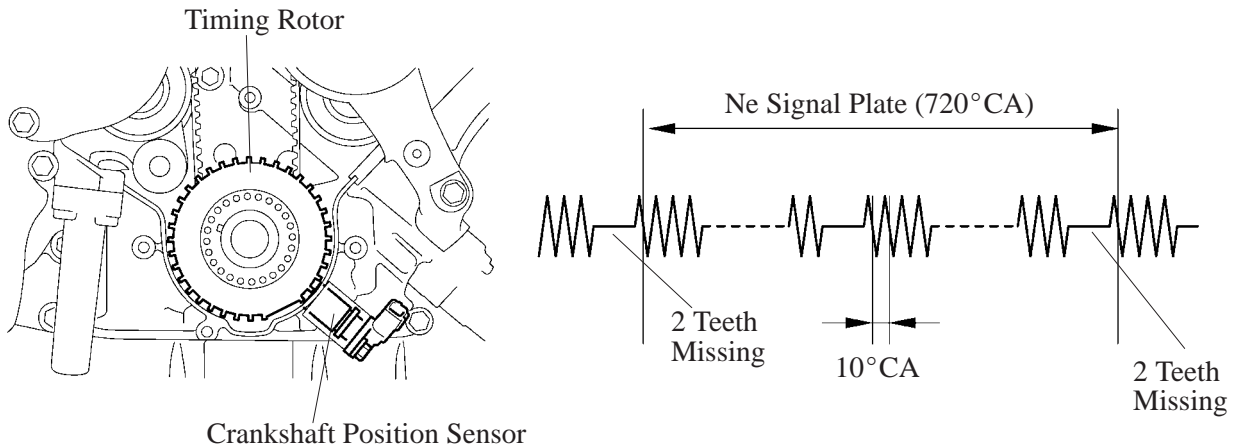

199EG36

### Camshaft Position Sensor

The camshaft position sensor is mounted on the left bank cylinder head. To detect the camshaft position, a protrusion that is provided on the timing pulley is used to generate 1 pulse for every 2 revolution of the crankshaft.

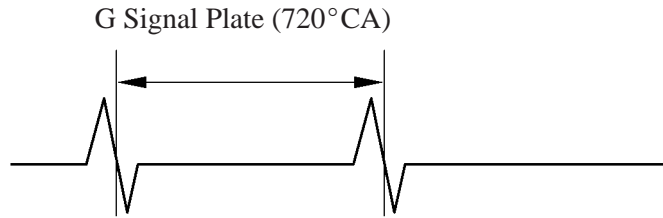
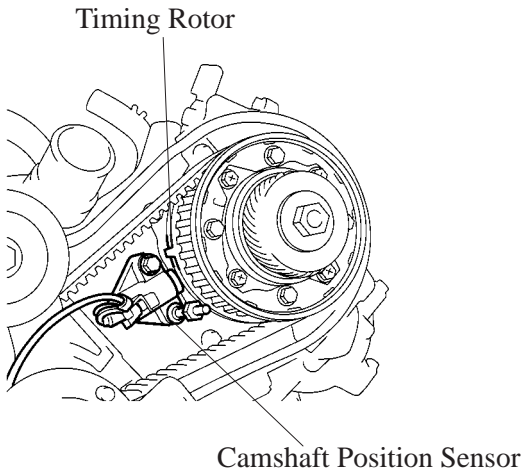

199EG37

### VVT Sensor

A VVT sensor is mounted on the intake side of each cylinder head. To detect the camshaft position, a timing rotor that is provided on the intake camshaft is used to generate 3 pulses for every 2 revolutions of the crankshaft.

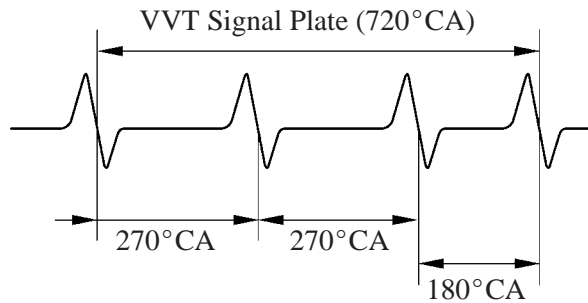
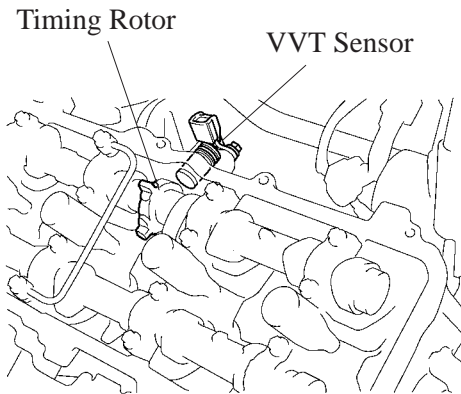

199EG38



**Throttle Position Sensor**

This sensor converts the throttle valve opening angles into electronic signals with two differing characteristics and outputs them to the engine ECU. One is the VTA signal that linearly outputs the voltage along the entire range of the throttle valve opening angle. The other is the VTA2 signal that outputs an offset voltage.

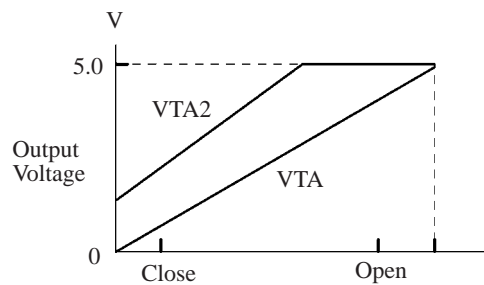
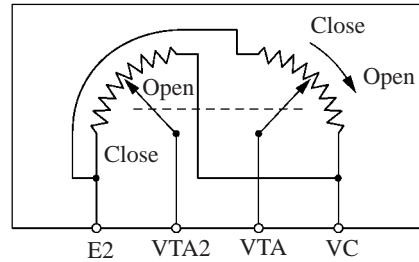
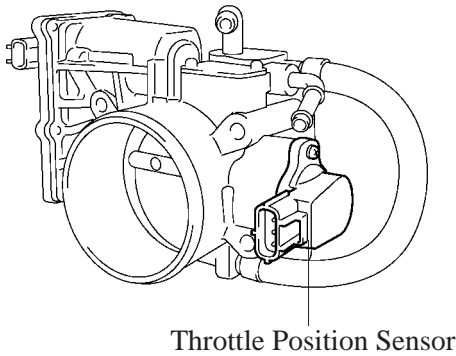

199EG39

**Accelerator Pedal Position Sensor**

This sensor converts the accelerator pedal depressed angles into electric signals with two differing characteristics and outputs them to the engine ECU. One is the VPA signal that linearly outputs the voltage along the entire range of the accelerator pedal depressed angle. The other is the VPA2 signal that outputs an offset voltage.

– *Changes (from 1UZ-FE Engine)* –

The accelerator pedal position sensor is attached to the accelerator pedal.

Accelerator Pedal Position Sensor

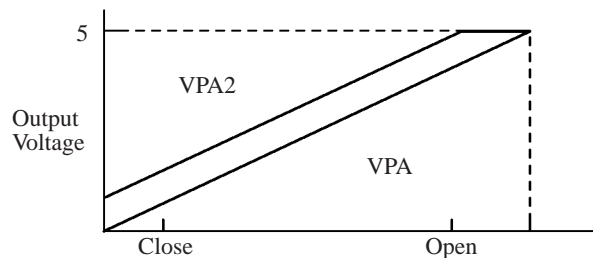
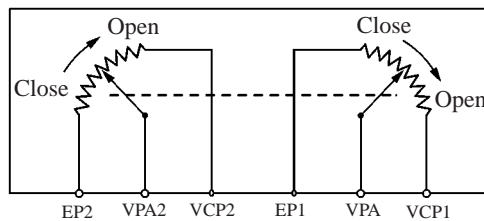
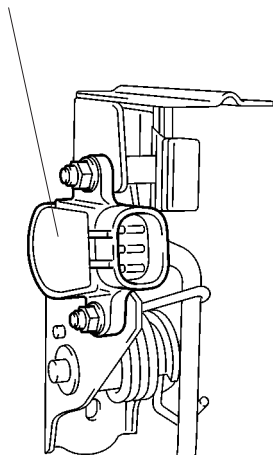

**Accelerator Pedal Depressed Angle**

199EG40

## 6. EFI (Electronic Fuel Injection) System

### General

- ▶ An L-type EFI system directly detects the intake air mass with a hot wire type air flow meter.
- ▶ An independent injection system (in which fuel is injected once into each cylinder for each two revolutions of the crankshaft) has been adopted.
- ▶ There are two types of fuel injection: One is synchronous injection in which corrections based on the signals from the sensors are added to the basic injection time so that injection occurs always at the same position. The other is non-synchronous injection in which injection is effected by detecting the requests from the signals of the sensors regardless of the crankshaft angle. Furthermore, to protect the engine and improve fuel economy, the system effects fuel cutoff in which the injection of fuel is stopped temporarily in accordance with the driving conditions.

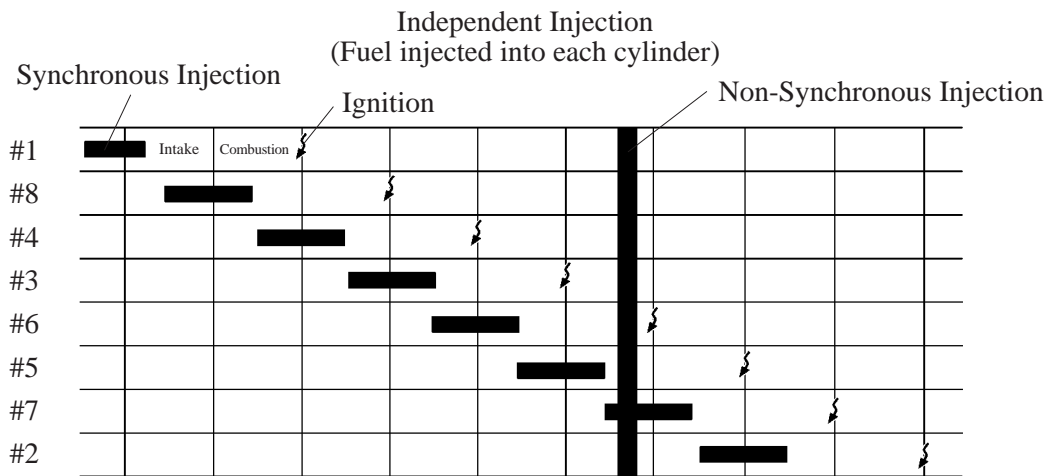

199EG41

### System Operation

#### 1) Synchronous Injection

The synchronous injection time can be expressed by the formula given below. During the starting of the engine, the injection time is determined in accordance with the engine speed, battery voltage, and the engine coolant temperature. To prevent excessive amounts of fuel from being injected during starting, the injection volume is regulated in accordance with the cranking time.

**Synchronous Injection =**

**A. Basic Injection Time + B. Correction Injection Time + C. Ineffective Injection Coefficient**

A. Basic Injection Time	It is the basic injection time that is determined by the intake air volume and the engine speed.
B. Correction Injection Time	It is a coefficient that is used to achieve the air-fuel mixture that is appropriate for the engine condition at that time, in accordance with the signals from the sensors.
Intake Temperature Correction	Enriches the mixture when the intake air temperature is low because the air density is high.
Post-Warm-Up Enrichment Correction	Enriches the mixture when the engine coolant temperature is low to ensure drivability during cold operation.
Post-Start Enrichment Correction	Enriches the mixture after the engine is started in accordance with the engine coolant temperature and the engine speed in order to ensure a stable engine operation after starting. The enrichment is at the highest ratio immediately after the engine is started, and decreases gradually thereafter.
Transient Air-Fuel Ratio Correction	Enriches or leans the mixture in accordance with the acceleration or deceleration conditions determined by the changes in the intake air volume.
Wall Adhesion Correction	Correction is made by calculating the adhesion of fuel to the wall surface based on the engine coolant temperature, engine speed, and throttle valve opening.
High-Load Enrichment Correction	Prevents the exhaust temperature from rising by detecting the high-load driving conditions in accordance with the signals from the sensors and enriching the mixture.
Constant Fuel Pressure Control	Corrects the deviation of the fuel injection volume that results from the changes in the intake manifold pressure to achieve a constant pressure.
Air-Fuel Ratio Feedback Control	Controls the air-fuel ratio to a narrow range near the stoichiometric ratio (in which the cleaning performance of the three-way catalyst is at the highest level) by making corrections based on the signals from the heated oxygen sensor.
C. Ineffective Injection Coefficient	Corrects the operation lag of the injectors

## 2) Non-Synchronous Injection

Apart from the normal (synchronous) fuel injection, this function simultaneously injects a prescribed volume of fuel to all the cylinders only immediately after the signals from the sensors are input, in order to ensure the proper startability and acceleration response.

During synchronous injection, the injection time is extended for the amount of non-synchronous injection. The following are the three types of non-synchronous injection:

Starting Non-Synchronous Injection	Effects non-synchronous injection once immediately after the starter signal is input, thus improving startability.
Acceleration Non-Synchronous Injection	Effects non-synchronous injection when the increased amount of the throttle valve opening is greater than the preset value, to improve response during acceleration.
Engine Speed Drop Non-Synchronous Injection	Effects non-synchronous injection when the engine speed drops suddenly during a fuel cutoff or when resuming from a fuel cutoff, thus ensuring the proper drivability.

### 3) Fuel Cutoff

The following are the three types of fuel cutoff:

Deceleration Fuel Cutoff	Stops the injection of fuel when the engine speed is higher than the specified value (1400 rpm) during deceleration (throttle OFF detected by engine ECU). This prevents the TWC (Three-Way Catalyst) from overheating due to misfiring and improves fuel economy. The fuel cutoff and resumption speeds are higher when the coolant temperature is low.
Engine Speed Fuel Cutoff	Stops the injection of fuel when the engine speed is higher than the specified value (6450 rpm) to prevent over-revolution.
N → D Shift Fuel Cutoff	Stops the injection of fuel for a prescribed length of time when shifting from N to D, if the engine speed is higher than the specified value to reduce shift shock.

## 7. ESA (Electronic Spark Advance) System

This system selects the optimal ignition timing in accordance with the signals received from the sensors and sends the (IGt) ignition signal to the igniter. The ignition timing can be expressed by the formula given below. The default ignition timing is set to 5° BTDC.

**Ignition Timing =**

**A. Default Ignition Timing or B. Basic Timing Advance + C. Correction Timing Advance**

A. Fixed Timing Advance Characteristic	During the starting of the engine, the timing is fixed to 5° BTDC. If the throttle valve is turned OFF by shorting the service terminals, the timing becomes fixed to 10° BTDC.
B. Basic Timing Advance Characteristic	The optimal ignition timing is selected from the map based on the signals received from the sensors.
C. Correction Timing Advance Characteristic	Appropriately advances or retards the timing in accordance with the conditions of the engine based on the signals received from the sensors.
Warm-Up Timing Advance Characteristic	Advances the ignition timing in accordance with the driving conditions when the engine coolant temperature is low, in order to improve drivability.
Idle Stabilization Timing Advance Characteristic	Advances the ignition timing when the idle speed decreases, in order to stabilize the idle speed. Conversely, retards the timing if the idle speed increases.
Fuel Cutoff Resumption Timing Retard	Retards the ignition timing when the fuel injection is resumed from a fuel cutoff, in order to lessen the shock.
Acceleration Timing Retard	Temporarily retards the ignition timing during acceleration in order to improve drivability.
Knock Correction Timing Retard	Corrects the ignition timing in accordance with the signals received from the knock sensor when knocking occurs. Depending on the extent of the knocking that is detected, this function retards the timing by a prescribed angle at a time until there is no more knocking. After no more knocking occurs, this function advances the timing by a prescribed angle at a time. If knocking occurs again while advancing the timing, it retards the timing again. Maximum Timing Advance: 48° BTDC Minimum Timing Advance: 10° ATDC

## 8. VVT-i (Variable Valve Timing – intelligent) System

### General

- The VVT-i system is designed to control the intake camshaft within a wide range of  $45^\circ$  (of crankshaft angle) to provide a valve timing that is optimally suited to the engine condition, thus realizing improved torque in all the speed ranges and fuel economy, and reduce exhaust emissions.

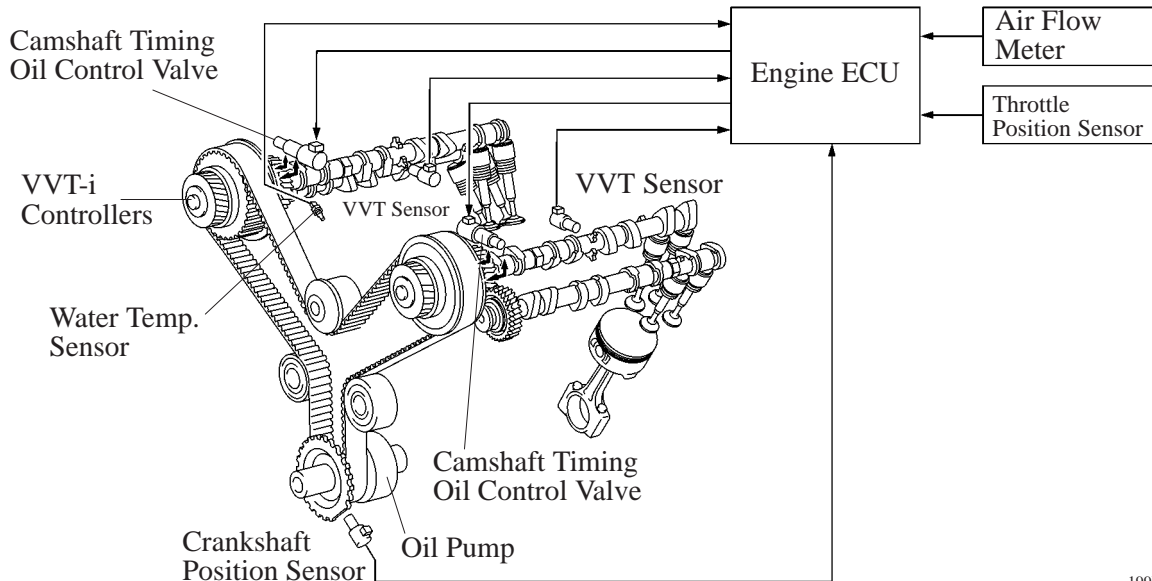

199EG42

- In proportion to the engine speed, intake air volume, throttle position and engine coolant temperature, the engine ECU calculates an optimal valve timing under each driving condition and control the camshaft timing oil control valve. In addition, engine ECU uses signal from the VVT sensors and the crankshaft position sensor to detect the actual valve timing, thus performing feedback control to achieve the target valve timing.

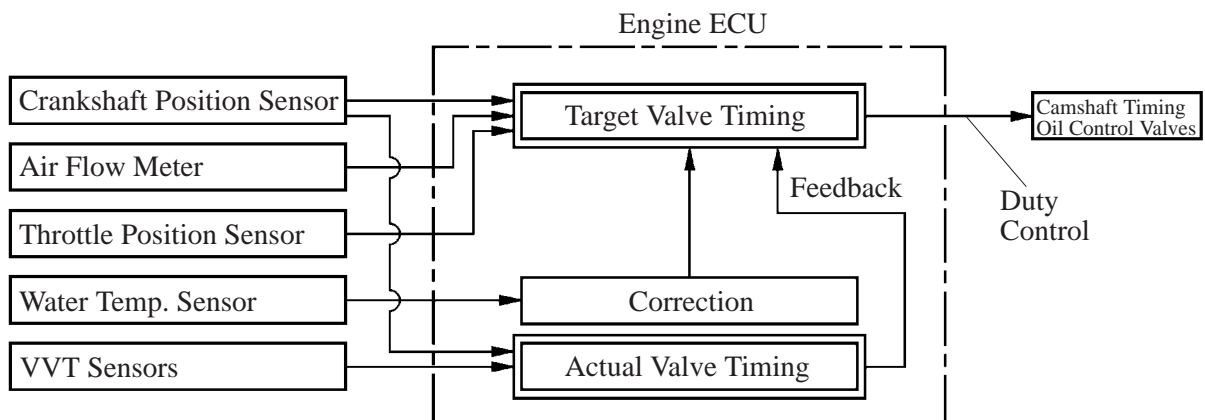

157EG23

### – Changes (from 1UZ-FE Engine) –

Due to the engine characteristics, the operation range of the VVT-i system has been changed from  $50^\circ$  (of crankshaft angle) to  $45^\circ$ . This is determined by the helical spline angle of the VVT-i controller.

**Construction**

**1) VVT-i Controller**

The VVT-i controller comprises the outer gear that is driven by the timing belt, the inner gear that is affixed to the camshaft and a movable piston that is placed between the outer gear and inner gear. Having helical splines (twisted, vertical grooves) on its inner and outer periphery, the piston moves in the axial direction to shift the phase of the outer gear and inner gear, thus causing the valve timing to change continuously.

The VVT tube drives the exhaust camshaft via the scissors gear that is installed on the back.

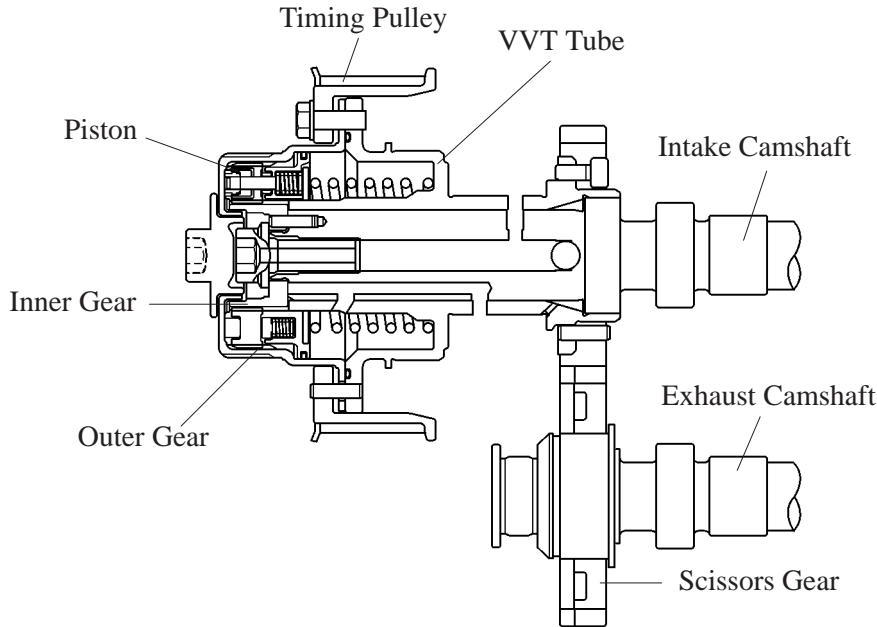

151EG29

**2) Camshaft Timing Oil Control Valve**

- The camshaft timing oil control valve controls the spool valve position in accordance with the duty control from the engine ECU.
- When the engine is stopped, the camshaft timing oil control valve is in the most retarded state.

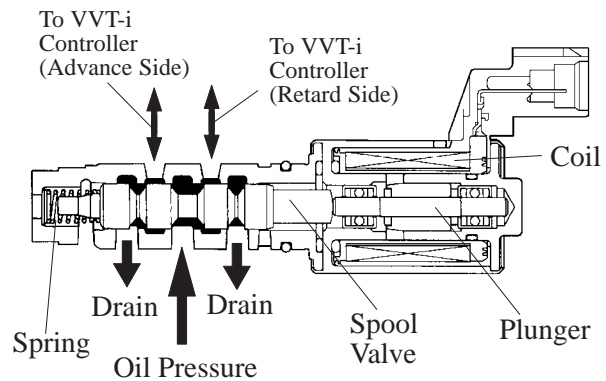

165EG34

## Operation

The camshaft timing oil control valve selects the path to the VVT-i controller according to the advance, retard or hold signal from the engine ECU. The VVT-i controller rotates the intake camshaft in the timing advance or retard position or holds it according to the position where the oil pressure is applied.

	Operation	Camshaft Timing Oil Control Valve Drive Signal	Description
Advance	<p>188EG48</p>	<p>Advance Signal</p> <p>Duty Ratio</p> <p>157EG35</p>	<p>When the camshaft timing oil control valve is positioned as illustrated in accordance with the advance signal from the engine ECU, the oil pressure is applied to the chamber at the advance side. Then, the twist of the helical spline causes the camshaft to rotate in the direction of timing advance.</p>
Retard	<p>188EG49</p>	<p>Retard Signal</p> <p>Duty Ratio</p> <p>157EG36</p>	<p>When the camshaft timing oil control valve is positioned as illustrated in accordance with the retard signal from the engine ECU, the oil pressure is applied to the chamber at the retard side. Then, the twist of the helical spline causes the camshaft to rotate in the direction of timing retard.</p>
Hold	<p>188EG50</p>	<p>Hold Signal</p> <p>Duty Ratio</p> <p>157EG37</p>	<p>The engine ECU calculates the target timing angle according to the traveling state to perform control as described above. After setting at the target timing, the valve timing is held by keeping the camshaft timing oil control valve in the neutral position unless the traveling state changes.</p> <p>This adjusts the valve timing at the desired target position and prevents the engine oil from running out when it is unnecessary.</p>

► Operation During Various Driving Condition (Conceptual Diagram) ◀

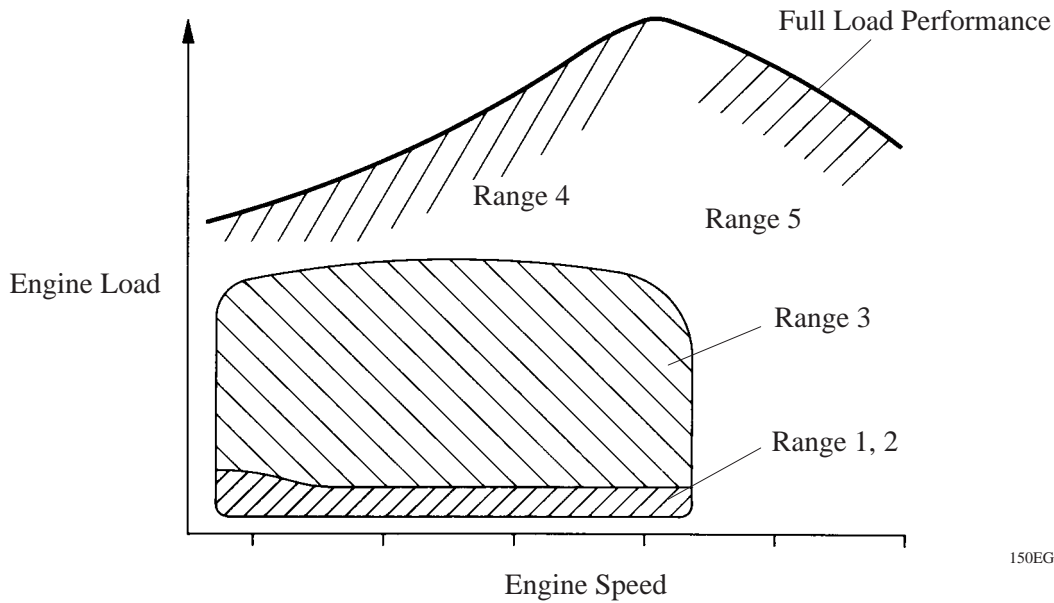

150EG34

Operation State	Range	Valve Timing	Objective	Effect
During Idling	1	<p>TDC</p> <p>Latest Timing</p> <p>EX IN</p> <p>BDC</p> <p>188EG51</p>	Eliminating overlap to reduce blow back to the intake side	Stabilized idling rpm Better fuel economy
At Light Load	2	<p>To Retard Side</p> <p>EX IN</p> <p>188EG64</p>	Decreasing overlap to eliminate blow back to the intake side	Ensured engine stability
At Medium load	3	<p>To Advance Side</p> <p>EX IN</p> <p>188EG65</p>	Increasing overlap to increase internal EGR for pumping loss elimination	Better fuel economy Improved emission control

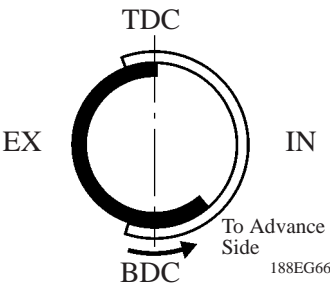
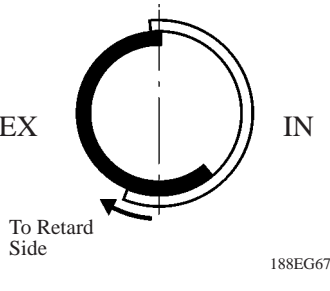
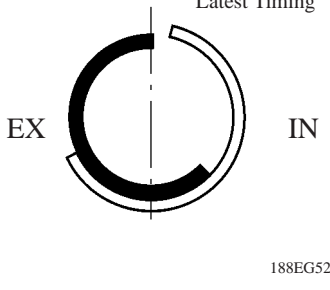
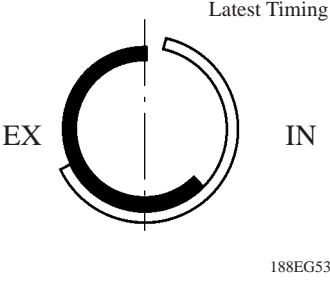

Operation State	Range	Valve Timing	Objective	Effect
In Low to Medium Speed Range with Heavy Load	4	<p>TDC</p>  <p>EX IN</p> <p>To Advance Side</p> <p>BDC</p> <p>188EG66</p>	Advancing the intake valve close timing for volumetric efficiency improvement	Improved torque in low to medium speed range
In High Speed Range with Heavy Load	5	 <p>EX IN</p> <p>To Retard Side</p> <p>188EG67</p>	Retarding the intake valve close timing for volumetric efficiency improvement	Improved output
At Low Temperatures	—	 <p>EX IN</p> <p>Latest Timing</p> <p>188EG52</p>	Eliminating overlap to prevent blow back to the intake side leads to the lean burning condition, and stabilizes the idling speed at fast idling.	Stabilized fast idle rpm Better fuel economy
Upon Starting/ Stopping the Engine	—	 <p>EX IN</p> <p>Latest Timing</p> <p>188EG53</p>	Eliminating overlap to minimize blow back to the intake side	Improved startability

## 9. ETCS-i (Electronic Throttle Control System-intelligent)

### General

In the conventional throttle body, the throttle valve opening is determined invariably by the amount of the accelerator pedal effort. In contrast, the ETCS-i uses the engine ECU to calculate the optimal throttle valve opening that is appropriate for the respective driving condition and uses a throttle control motor to control the opening.

– Changes –

(from 1UZ-FE Engine)

- The torque-activated power train control has been newly adopted. This control enables the engine to generate the necessary torque as desired by the driver, as well as to realize a smooth engine output characteristic.
- The accelerator cable and link have been discontinued, and an a accelerator position sensor has been provided on the accelerator pedal.
- Accordingly the limp-mode control during the fail-safe mode has been changed.

### ► System Diagram ◀

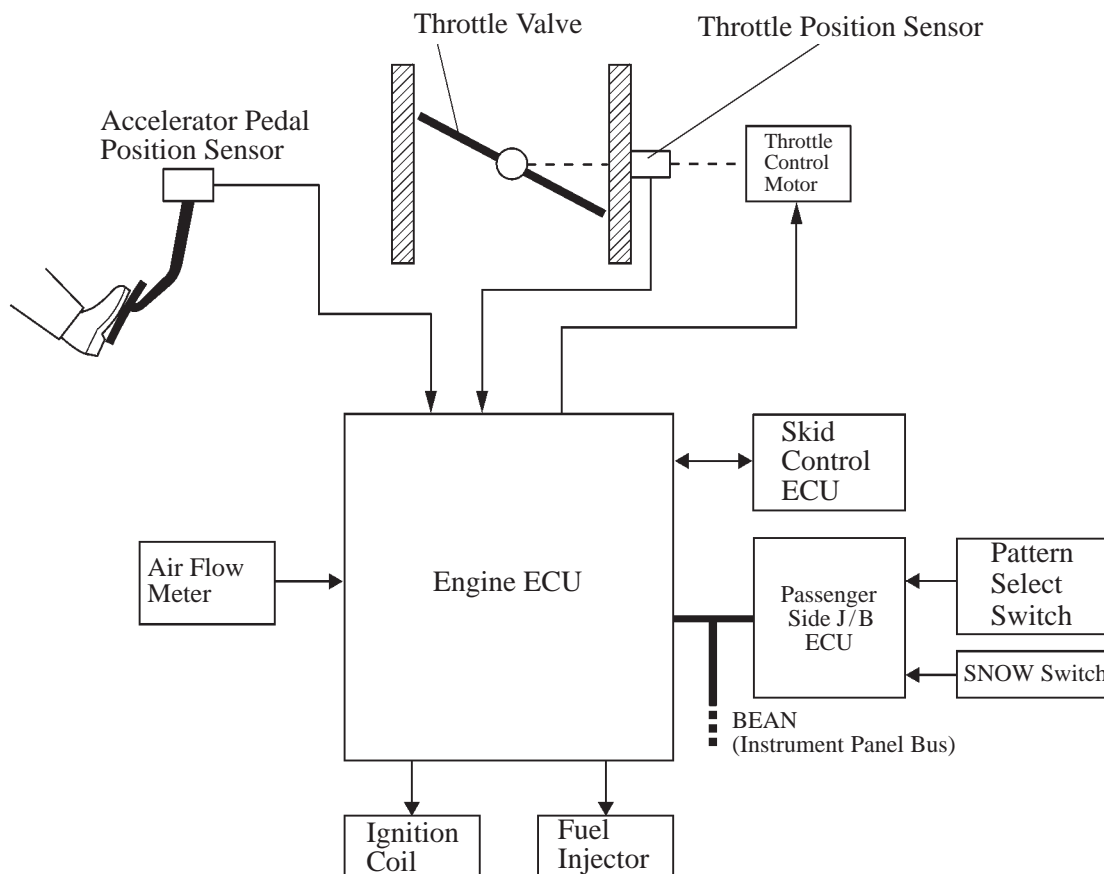

## Operation

### 1) General

The engine ECU drives the throttle control motor by determining the target throttle valve opening in accordance with the respective operation condition.

- Torque Activated Power Train Control
- Normal-mode Control, Power-mode Control, and SNOW-mode Control
- Idle Speed Control
- Shift Shock Reduction Control
- TRC Throttle Control
- VSC Coordination Control
- Cruise Control

### 2) Torque Activated Power Train Control

Controls the throttle to an optimal throttle valve opening that is appropriate for the driving condition such as the amount of the accelerator pedal effort and the engine operating condition. As a result, excellent throttle control and comfort in all operating ranges, as well as smooth startoff acceleration and elastic acceleration have been achieved.

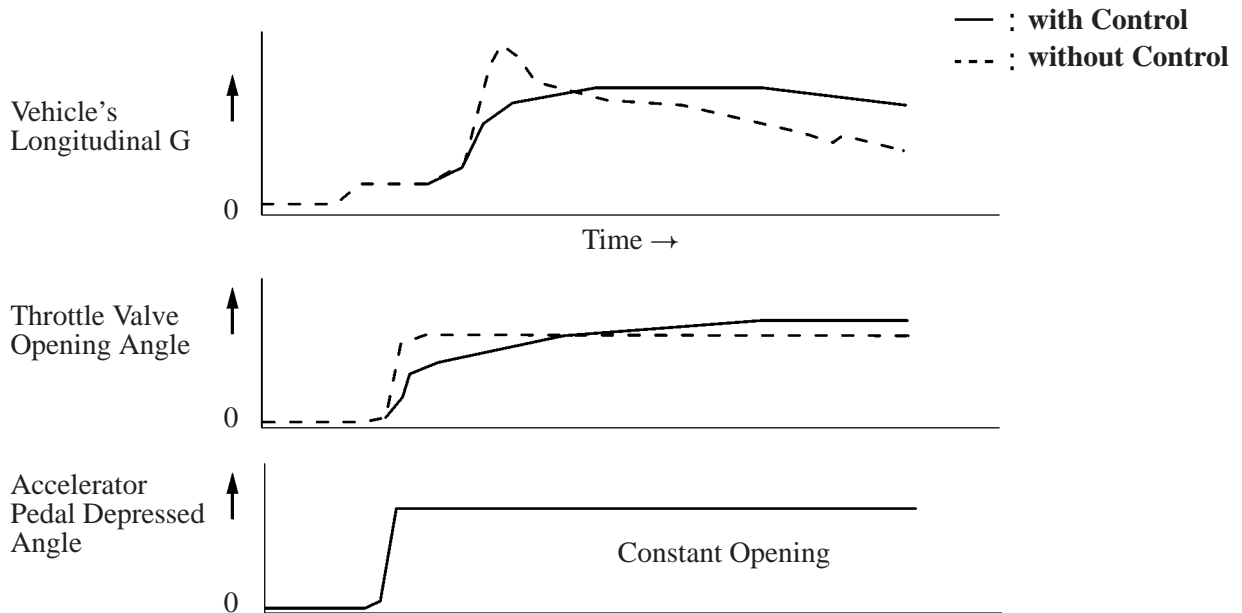

### 3) Normal-mode, Power-mode, SNOW-mode Controls

#### a. Normal-mode Control

Controls the throttle to an optimal throttle valve opening that is appropriate for the driving condition such as the amount of the accelerator pedal effort and the engine operating condition in order to realize excellent throttle control and comfort in all operating ranges.

#### b. Power-mode Control

If turning ON the POWER switch of the pattern select switch and selecting the power-mode, the throttle valve opening angle is controlled to react more directly to operation of the accelerator pedal than the normal mode. With this, sporty driving is realized.

#### c. SNOW-mode Control

In situations in which low- $\mu$  surface conditions can be anticipated, such as when driving in the snow, the throttle valve can be controlled to help vehicle stability while driving over the slippery surface. This is accomplished by turning on the SNOW switch of the pattern select switch, which, in response to the amount of the accelerator pedal effort that is applied, reduces the engine output from that of the normal driving level.

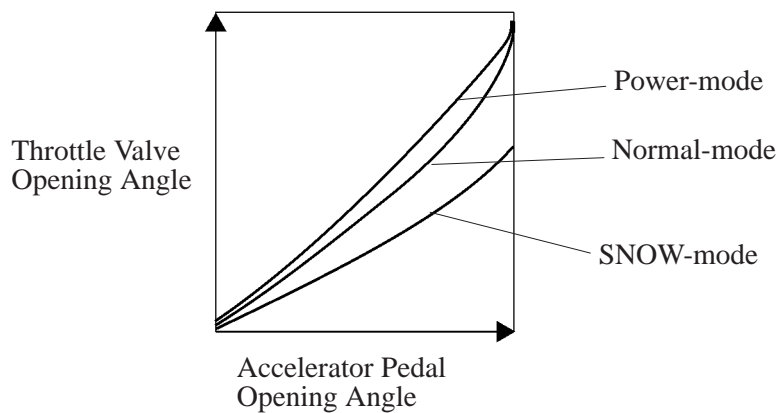

**Conceptual Diagram**

189EG38

### 4) Idle Speed Control

Controls the engine ECU and the throttle valve in order to constantly effect ideal idle speed control.

### 5) Shift Shock Reduction Control

The throttle control is synchronized to the ECT (Electronically Controlled Transmission) control during the shifting of the transmission in order to reduce the shift shock.

### 6) TRC Throttle Control

As part of the TRC system, the throttle valve is closed by a demand signal from the skid control ECU if an excessive amount of slippage is created at a driving wheel, thus facilitating the vehicle in ensuring stability and driving force.

### 7) VSC Coordination Control

In order to bring the effectiveness of the VSC system control into full play, the throttle valve opening angle is controlled by effecting a coordination control with the skid control ECU.

### 8) Cruise Control

An engine ECU with an integrated cruise control ECU directly actuates the throttle valve to effect the operation of the cruise control.

## 10. ACIS (Acoustic Control Induction System)

### General

The ACIS (Acoustic Control Induction System) is realized by using a bulkhead to divide the intake manifold into 2 stages, with an intake air control valve in the bulkhead being opened and closed to vary the effective length of the intake manifold in accordance with the engine speed and throttle valve opening angle. This increases the power output in all ranges from low to high speed.

– *Changes (from 1UZ-FE Engine)* –

Due to the engine characteristics, the operation range of the ACIS has been changed.

### ► System Diagram ◀

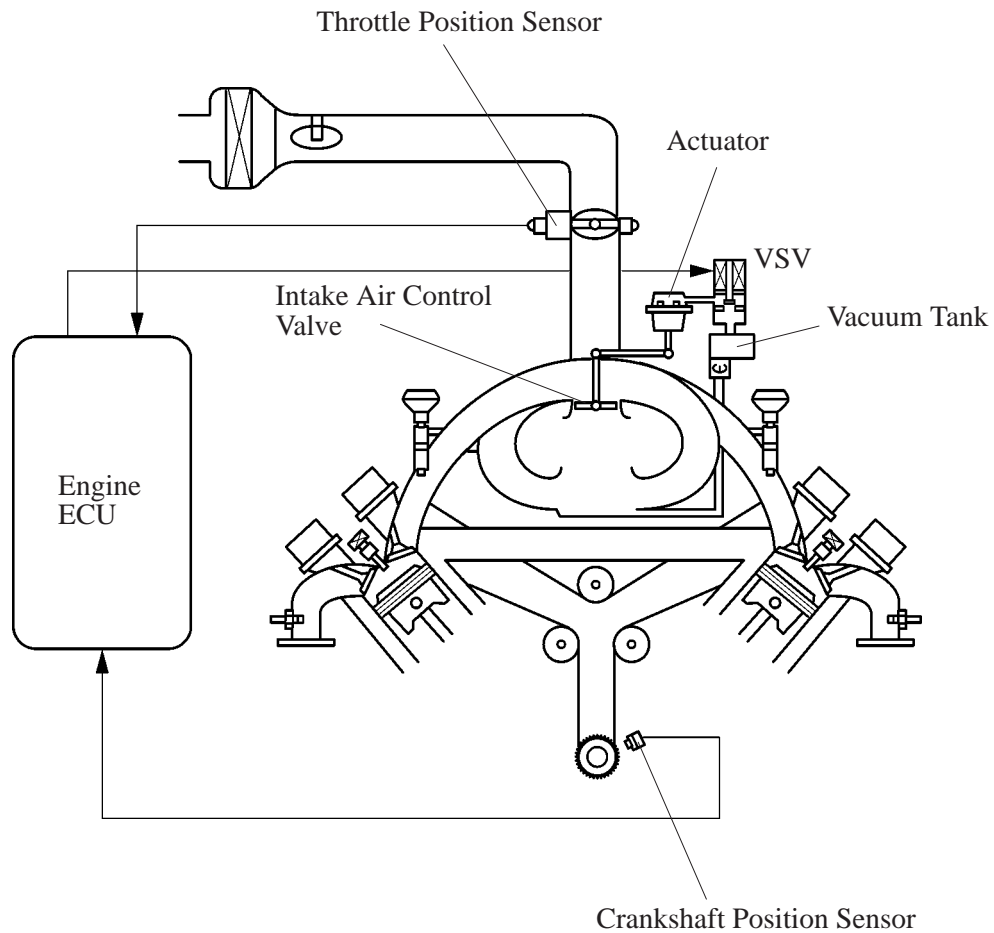

**Construction**

**1) Intake Air Control Valve**

The intake air control valve, which is provided in the middle of the intake manifold in the intake air chamber, opens and closes to change the effective length of the intake manifold in two stages.

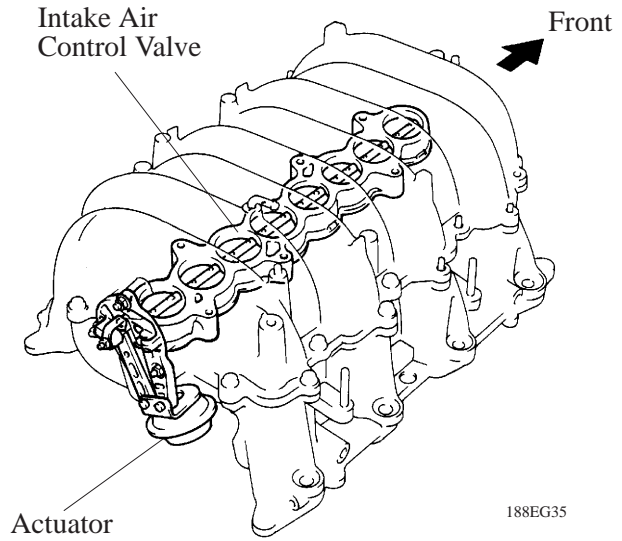

**2) VSV (Vacuum Switching Valve)**

Controls the vacuum that is applied to the actuator by way of the signal (ACIS) that is output by the engine ECU.

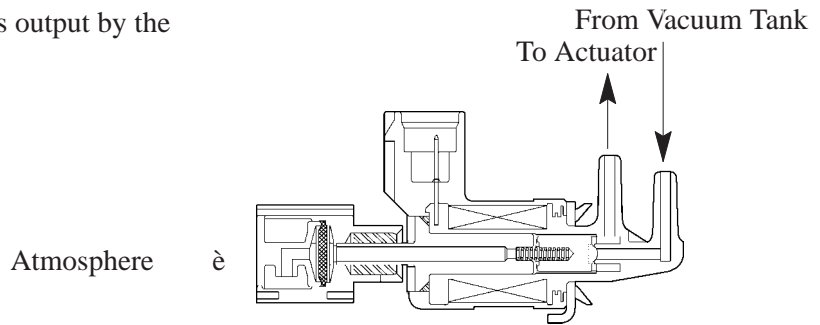

**3) Vacuum Tank**

Equipped with an internal check valve, the vacuum tank stores the vacuum that is applied to the actuator in order to maintain the intake air control valve fully closed even during low-vacuum conditions.

**Operation**

**1) When the Intake Control Valve Closes (VSV ON)**

The engine ECU activates the VSV to match the longer pulsation cycle so that the negative pressure acts on the diaphragm chamber of the actuator. This closes the control valve. As a result, the effective length of the intake manifold is lengthened and the intake efficiency in the low-to-medium speed range is improved due to the dynamic effect of the intake air, thereby increasing the power output.

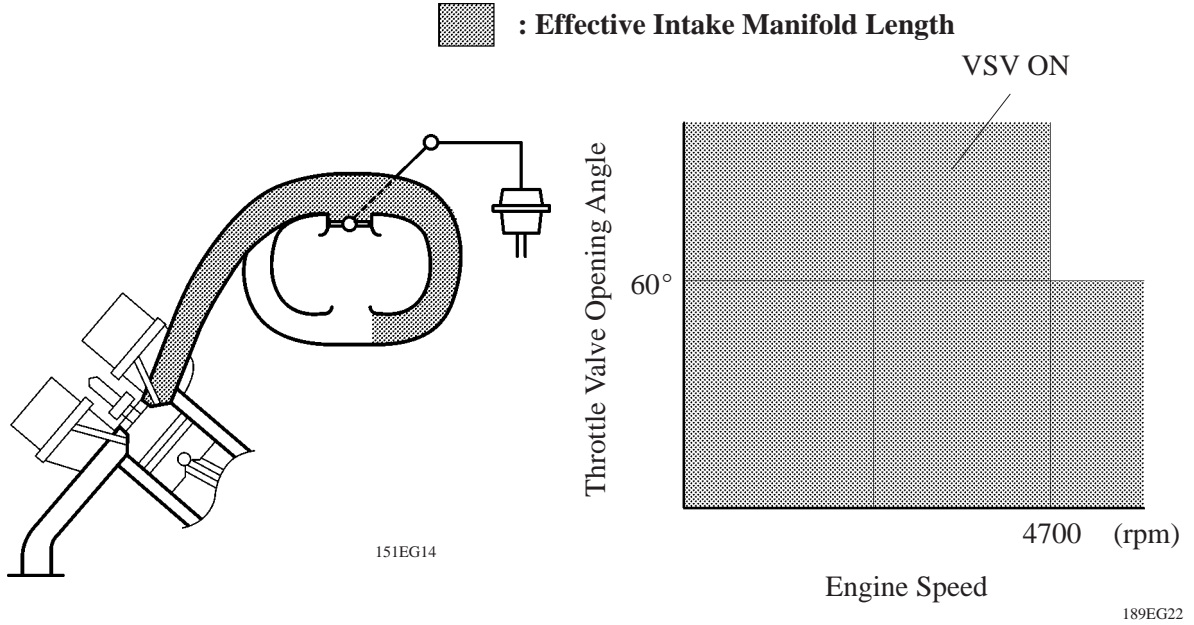

**2) When the Intake Control Valve Open (VSV OFF)**

The engine ECU deactivates the VSV to match the shorter pulsation cycle so that atmospheric air is led into the diaphragm chamber of the actuator and opens the control valve. When the control valve is open, the effective length of the intake air chamber is shortened and peak intake efficiency is shifted to the high engine speed range, thus providing greater output at high engine speeds.

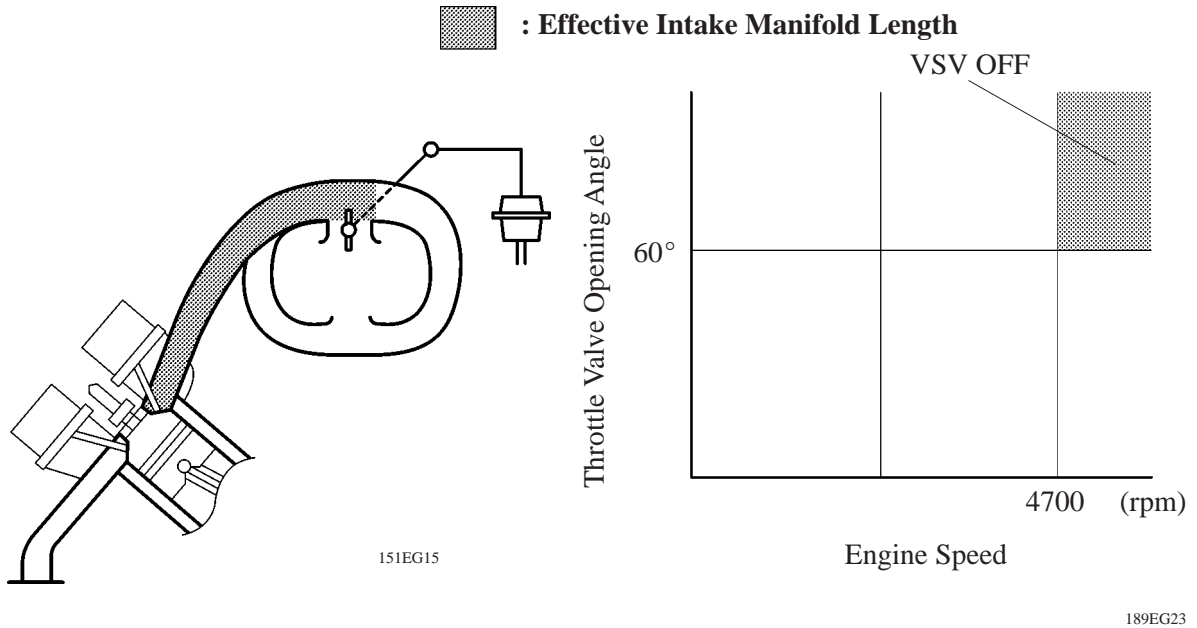

## 11. Cooling Fan System

### General

To achieve an optimal fan speed in accordance with the engine coolant temperature, vehicle speed, engine speed, and air conditioning operating conditions, the engine ECU calculates the proper fan speed and sends the signals to the cooling fan ECU. Upon receiving the signals from the engine ECU, the cooling fan ECU actuates the fan motors. Also, the fan speed is controlled by engine ECU using the stepless control.

### ► Wiring Diagram ◀

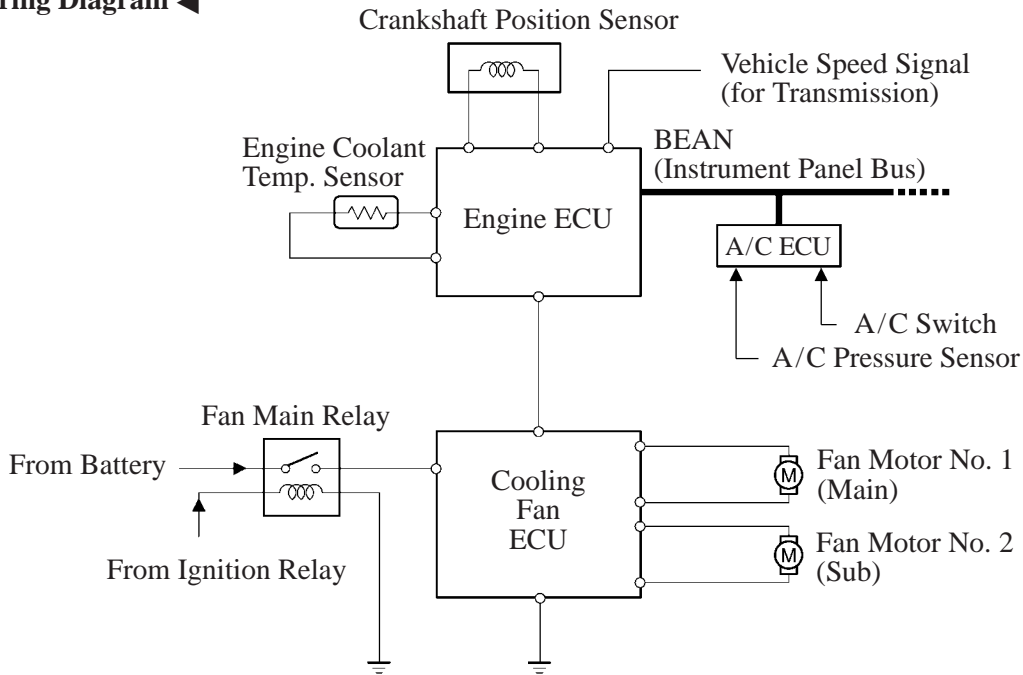

199EG44

### Operation

As illustrated below, the engine ECU determines the required fan speed by selecting the fastest fan speed from among the following:

- (A) The fan speed required by the engine coolant temperature.
- (B) The fan speed required by the air condition refrigerant pressure.
- (C) The fan speed required by the engine speed.
- (D) The fan speed required by the vehicle speed.

The cooling fan ECU controls fan motors No. 1 and No. 2 in accordance with the signals received from the engine ECU.

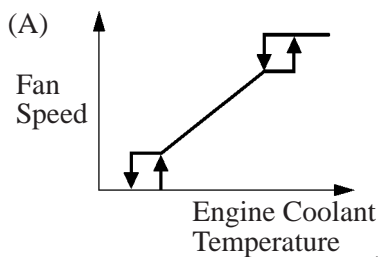

189EG13

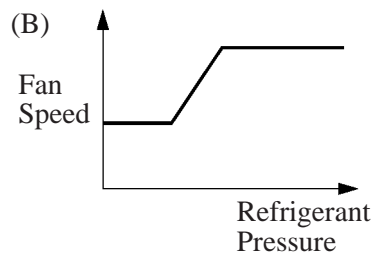

189EG14

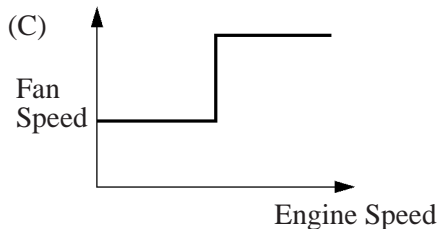

189EG15

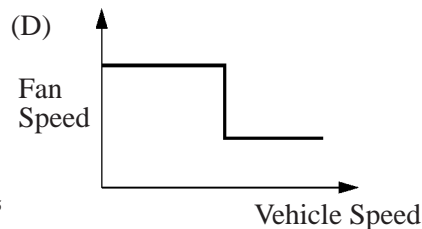

189EG16



## 12. Fuel Pump Control

- This control system increases the fuel pump output by switching the fuel pump speed to high if a large amount of fuel is required by the engine ECU. In normal operations where the engine speeds are low, the fuel pump rotates at low speed to reduce unnecessary consumption of electric power and to maintain fuel pump durability.
- A fuel cut control is adopted to stop the fuel pump when the airbag is deployed at the front or side collision. In this system, the airbag deployment signal from the airbag sensor assembly is detected by the engine ECU, which turns OFF the circuit opening relay. After the fuel cut control has been activated, turning the ignition switch from OFF to ON cancels the fuel cut control, thus engine can be restarted.

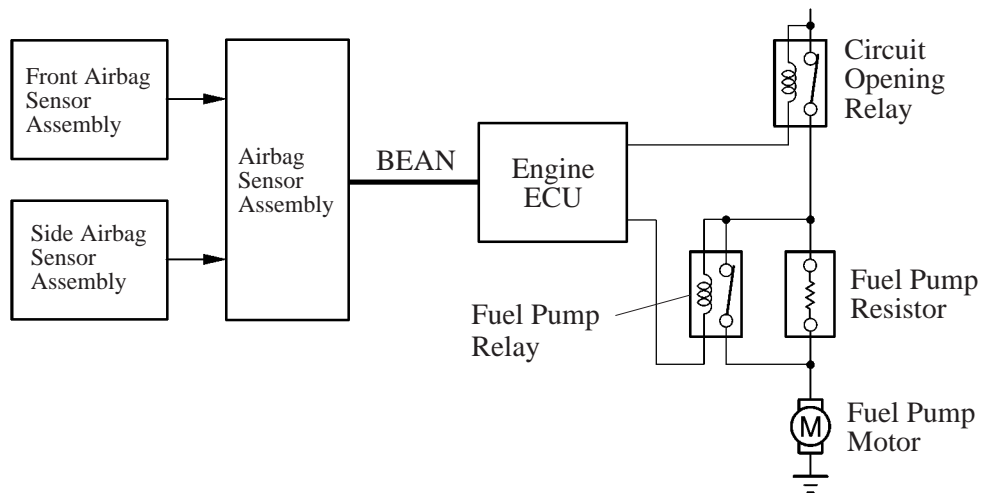

199EG52

### 13. Diagnosis

When the engine ECU detects a malfunction, the engine ECU makes a diagnosis and memorizes the failed section. Furthermore, the check engine warning light in the combination meter illuminates or blinks to inform the driver. The engine ECU will also store the DTCs of the malfunctions. The DTCs can be accessed the use of the hand-held tester or SST (09845-18040). For details, see the LEXUS SC430 Repair Manual (Pub. No. RM858E).

– *Changes (from 1UZ-FE Engine) –*

- The diagnosis system of the Europe model has adopted the EURO-OBD (Europe On-Board Diagnosis) that complies with European regulations.
- The diagnosis system of the Australia model has adopted the M-OBD (Multiplex On-Board Diagnosis).

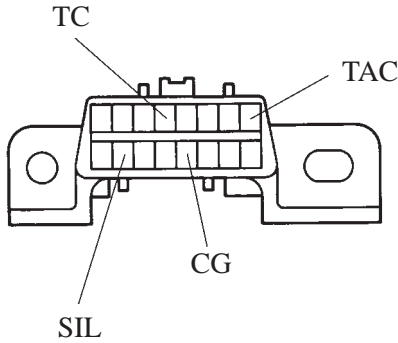
Item	EURO-OBD, M-OBD
<p>Data Link Connector</p>	<div style="text-align: center;"> <p>► DLC3 ◄</p>  <p>The diagram shows a top-down view of the DLC3 connector. It is a rectangular plastic housing with a central row of 16 pins. Four terminals are specifically labeled: TC at the top center, TAC at the top right, CG at the bottom center, and SIL at the bottom left. The connector is mounted on a metal bracket with two circular holes on either side.</p> </div> <p style="text-align: right; font-size: small;">165EG39</p> <p>CG: Chassis Ground  SIL: Provides communication between the engine ECU and the hand-held tester.  TAC: Outputs the engine speed signal.  TC: Provides the same function as the previous TE1 and Tc terminals.</p>
<p>Diagnostic Trouble Code Check Method</p>	<p>The diagnostic trouble codes can be displayed by connecting a hand-held tester to the DLC3. After terminals TC and CG of the DLC3 are connected, the codes are displayed on the check engine warning light in the combination meter.</p>

- Furthermore, the functions listed below can be utilized by connecting the hand-held tester to the DLC3. The diagnosis system of the EURO-OBD system and M-OBD system are compared below.

Function	Details	EURO-OBD	M-OBD
Diagnostic Trouble Code	<p>The system can output 5-digit diagnostic trouble codes to the tester, which are more detailed than the previous 2-digit diagnostic trouble codes, thus making it easier to identify the location of the problem.</p> <p>Example: Code 28 (Oxygen Sensor)</p> <pre> graph LR     A[Code 28 (Oxygen Sensor)] --&gt; B[P0130 (Oxygen Sensor)]     A --&gt; C[P0135 (Oxygen Sensor Heater)] </pre> <p>However, in the EURO-OBD system, the diagnostic trouble codes that are not output by the M-OBD, such as misfires, are also output. Refer to the LEXUS SC430 Repair Manual (Pub. No. RM858E).</p>	○	○
Continuous Test Results	A diagnostic trouble code may require a condition to be present for several drive cycles, while the equivalent continuous test code may be set with the first occurrence of the condition.	○	—
Freeze-Frame Data	The system can output freeze-frame data to the tester. This data (which depicts the condition of the engine control system and the vehicle) is stored in the engine ECU at the very moment when the engine ECU has detected its last data of malfunction.	○	○
Output Engine ECU Data	The engine ECU's control data can be output. Output Data Speed: 9.6 kbps	○	○
Active Test	Through the use of the tester, the actuators (VSV, fuel pump, VVT-i system, etc.) can be activated to a desired state.	○	○
Trouble Code Clear	Through the use of the tester, trouble codes that are stored in the engine ECU can be cleared.	○	○
Check Engine Warning Light Clear	If the engine ECU detects the malfunction of the vehicle, it makes the check engine warning light come on. Later, if that malfunction will not occur again, it automatically turns off the check engine warning light.	—	○
	If the engine ECU detects the malfunction of the vehicle, it makes the check engine warning light come on. Later, if the same malfunction will not occur again during 3 trips continuously, it automatically turns off the check engine warning light.	○	—

- For details on the diagnostic trouble codes, active test, etc. described above, refer to the LEXUS SC430 Repair Manual (Pub., No. RM858E).
- For details of the hand-held tester, refer to the Hand-Held Tester Operator's Manual.

- The DTCs (Diagnostic Trouble Codes) listed below have been added or discontinued.

► **EURO-OBD Added DTCs** ◀

DTC No.	Detection Item	DTC No.	Detection Item
P0116/22	Engine Coolant Temp. Circuit Range/Performance Problem	P0307/94	Cylinder 7 Misfire Detected
		P0308/94	Cylinder 8 Misfire Detected
P0125/91	Insufficient Coolant Temp. for Closed Loop Fuel Control	P0420/94	Catalyst System Efficiency Below Threshold (Bank 1)
P0133/21	Oxygen Sensor Circuit Slow Response (Bank 1, Sensor 1)	P0430/94	Catalyst System Efficiency Below Threshold (Bank 2)
P0153/28	Oxygen Sensor Circuit Slow Response (Bank 2, Sensor 1)	P0443/94	Evaporative Emission Control System Purge Control Vent Control Malfunction
P0172/26	System too Rich (A/F Rich Malfunction, Bank 1)		
P0175/26	System too Rich (A/F Rich Malfunction, Bank 2)	P1346/18	VVT Sensor/Camshaft Position Sensor Circuit Range/Performance Problem (Bank 1)
P0300/93	Random/Multiple Cylinder Misfire Detected		
P0301/94	Cylinder 1 Misfire Detected		
P0302/94	Cylinder 2 Misfire Detected	P1351/18	VVT Sensor/Camshaft Position Sensor Circuit Range/Performance Problem (Bank 2)
P0303/94	Cylinder 3 Misfire Detected		
P0304/94	Cylinder 4 Misfire Detected	P1520/95	Stop Light Switch Signal Malfunction
P0305/94	Cylinder 5 Misfire Detected		
P0306/94	Cylinder 6 Misfire Detected	P1600/96	Engine ECU BATT Malfunction
		P1651/96	VSV for ACIS Circuit Malfunction

► **M-OBD Added DTCs** ◀

DTC No.	Detection Item
P1346/18	VVT Sensor/Camshaft Position Sensor Circuit Range/Performance Problem (Bank 1)
P1351/18	VVT Sensor/Camshaft Position Sensor Circuit Range/Performance Problem (Bank 2)
P1520/95	Stop Light Switch Signal Malfunction

► **EURO-OBD and OBD Discontinued DTC** ◀

DTC No.	Detection Item
P1126/89	Magnetic Clutch Circuit Malfunction

## 14. Fail-Safe

### General

When the engine ECU detects a malfunction, the engine ECU stops or controls the engine according to the data already stored in the memory.

#### ► Fail-Safe Control List ◀

: Changes

Location of Malfunction	Description of Control
Air Flow Meter	In case of a signal malfunction, the engine could operate poorly or the catalyst could overheat if the engine continues to be controlled with the signals from the sensors. Therefore, the engine ECU effects control by using the values in the engine ECU or stops the engine.
Accelerator Pedal Position Sensor (For details, <a href="#">see page EG-67</a> )	In case of a signal malfunction, the engine ECU calculates the accelerator pedal opening angle that is limited by the dual system sensor value and continues effecting throttle valve control. If both systems malfunction, the engine ECU considers that the accelerator pedal is fully closed.
Throttle Position Sensor (For details, <a href="#">see page EG-67</a> )	In case of a signal malfunction, the engine ECU cuts off the current to the throttle control motor. The throttle valve returns to the prescribed opening by the force of the return spring. The engine ECU then adjusts the engine output by controlling the fuel injection and ignition timing in accordance with the accelerator pedal opening angle to enable the vehicle to continue driving.
Water Temp. Sensor and Intake Air Temp. Sensor	In case of a signal malfunction, the use of the values from the sensors will make the air-fuel ratio become too rich or too lean, which could cause the engine to stall or to run poorly during cold operation. Therefore, the engine ECU fixes the air-fuel ratio to the stoichiometric ratio and uses the constant values of 80°C engine coolant temperature and 20°C intake air temperature to perform the calculation.
Knock Sensor	In case of a malfunction in the knock sensor or in the knocking signal system (open or short circuit), the engine could become damaged if the timing is advanced despite the presence of knocking. Therefore, if a malfunction is detected in the knock sensor system, the engine ECU turns the timing retard correction of the knock sensor into the maximum retard value.
Ignition Coil (with Igniter)	In case of a malfunction in the ignition system, such as an open circuit in the ignition coil, the catalyst could become overheated due to engine misfire. Therefore, if the (IGf) ignition signal is not input twice or more in a row, the engine ECU determines that a malfunction occurred in the ignition system and stops only the injection of fuel into the cylinder with the malfunction.
Camshaft Position Sensor and VVT Sensor	In case of a signal malfunction (open or short circuit) or a mechanical malfunction, the engine ECU stops the VVT-i control.

**Fail-Safe of Accelerator Pedal Position Sensor**

- The accelerator pedal position sensor comprises two (main, sub) sensor circuits. If a malfunction occurs in either one of the sensor circuits, the engine ECU detects the abnormal signal voltage difference between these two sensor circuits and switches to the limp mode. In the limp mode, the remaining circuit is used to calculate the accelerator pedal opening, in order to operate the vehicle under limp mode control.

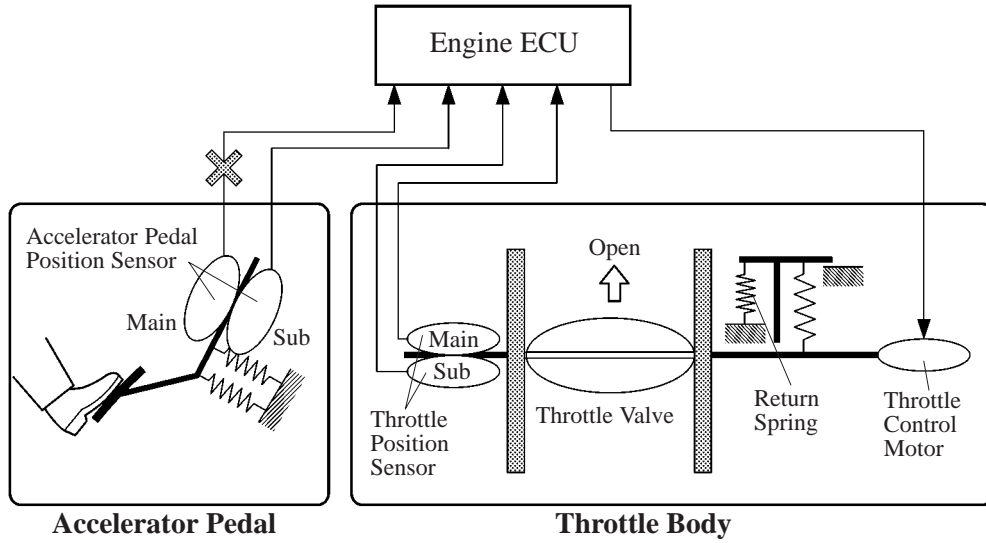

199EG45

- If both systems malfunction, the engine ECU detects the abnormal signal voltage between these two sensor circuits and regards that the opening angle of the accelerator pedal is fully opened and then continues the throttle control. At this time, the vehicle can be driven within its idling range.

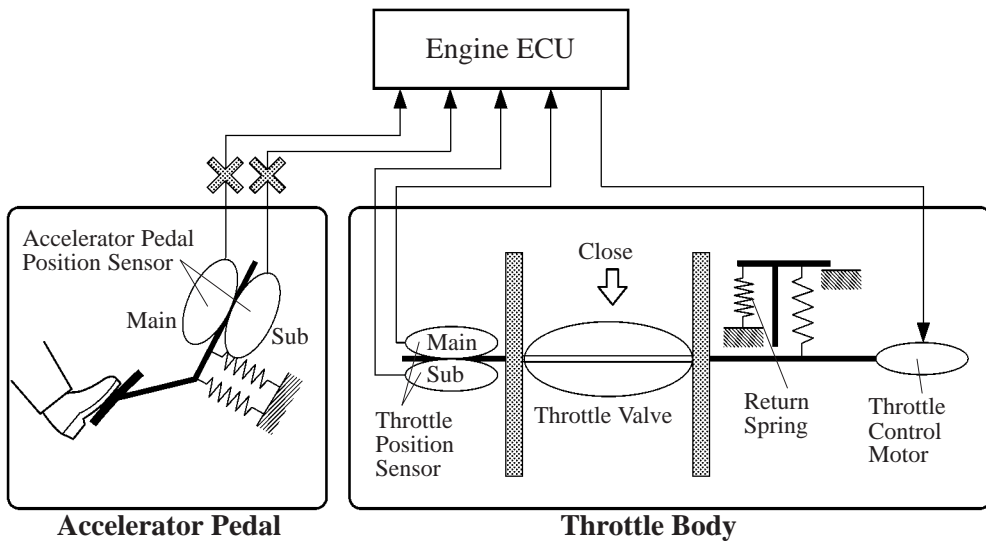

199EG46

### Fail-Safe of Throttle Position Sensor

- The throttle position sensor comprises two (main, sub) sensor circuits. If a malfunction occurs in either one of the sensor circuits, the engine ECU detects the abnormal signal voltage difference between these two sensor circuits, cuts off the current to the throttle control motor, and switches to the limp mode. Then, the force of the return spring causes the throttle valve to return and stay at the prescribed opening. At this time, the vehicle can be driven in the limp mode while the engine output is regulated through the control of the fuel injection and ignition timing in accordance with the accelerator opening.
- The same control as above is effected if the engine ECU detects a malfunction in the throttle control motor system.

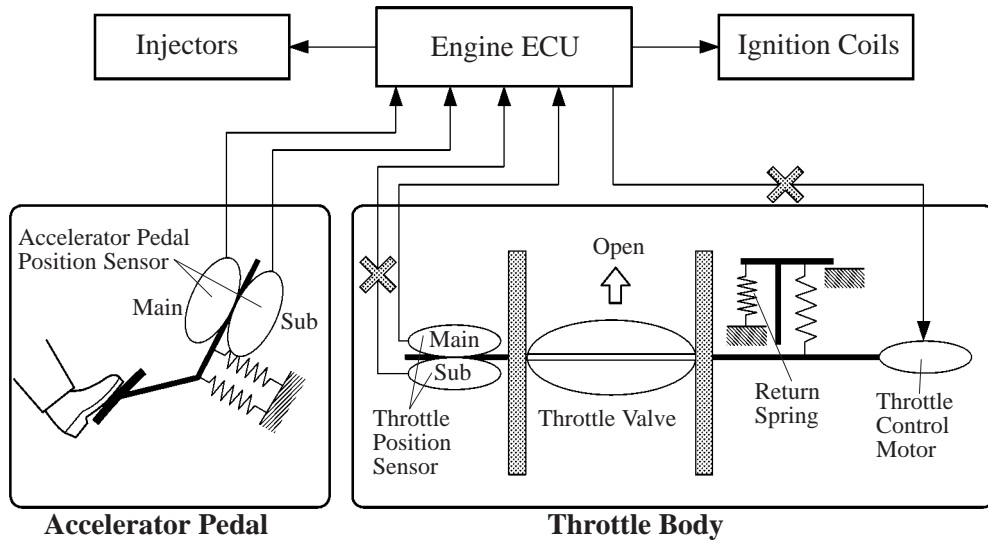

199EG47