

LuxLink Installation Guide

An INCOMPLETE GUIDE as
of September 4, 2011.
Use this material in conjunction
with the LuxLink Installation file.

Use of this guide is at your own risk.

Luxury Motor Works, is the owner of the Lux Link intellectual property rights.
This guide is intended to help new Luxlink owners with the installation of their devices.

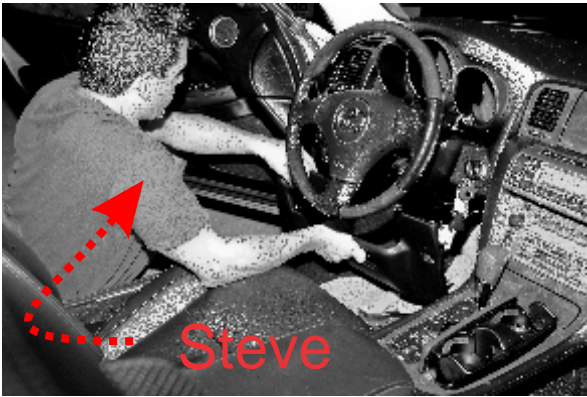

Remove the instrument panel kick plate which is held in with three screws as shown in the diagram. Disconnect the hood release cable and footwell light (not shown). Set the panel aside. It's the first piece to come out and the last piece to go back together.

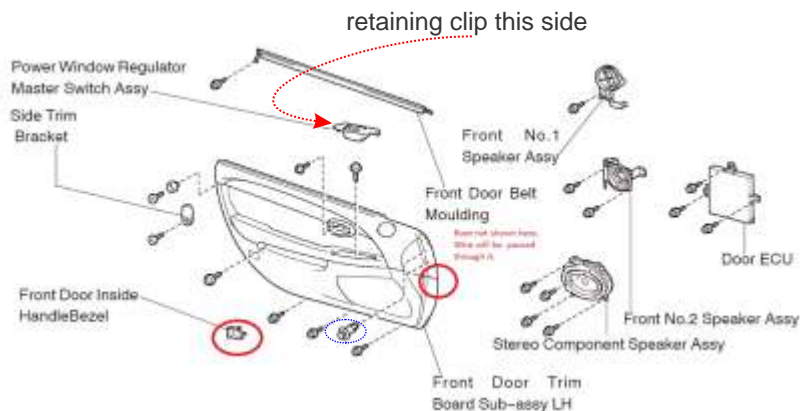

Next remove the interior driver's side door panel. (See diagram above) The hardest part to take out is the window switch. There is a retaining clip, you'll need to carefully slide a protected flat blade or tool between the leather and plastic, push forward and lift/tilt up. **Caution the leather tears easily.**



After taking out all the screws and **CLIP**, you'll pull out at the bottom and lift. You'll need to disconnect the door release handle and connector to the power lock switch. Also take out the door woofer and you'll also need to peel back the protective tape on wire bundle going to the ECU.



REMOVING DRIVERS FLOOR CARPET L/H KICK PANEL & SLIDING ROOF WIRING

Pull drivers floor carpet back towards brake pedal and gas pedal to allow for as much room as possible to access L/H junction block.

- Locate larger IC1 24 pin connector behind L/H carpet kick panel to access convertible top wires.
- Remove harness protective cover to access wires.
- Connect the Yellow wire **from LuxLink wire harness** (position J1.3) to the vehicle's Yellow and Black wire. (position IC1.2)
- Next, connect Green wire **from the LuxLink harness** (position J1.9) to the vehicle's Green with Yellow wire (position IC1.3)
- Next connect Violet wire **from the LuxLink harness** (position J1.6) to the car's Black with Yellow wire (position IC1.15).
- These three connections will be soldered. However, they should be tested **BEFORE soldering**. Once soldered, all three wires will be wrapped securely with electrical tape. Then reinstall harness protector.

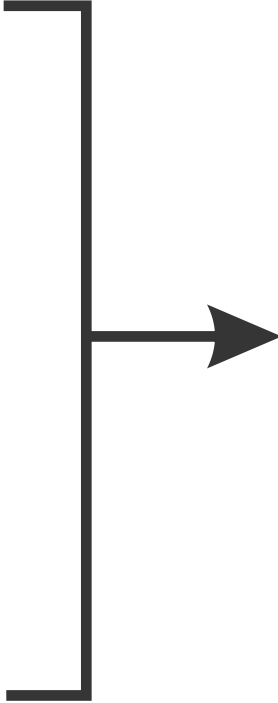

Front bottom curve of the door frame.

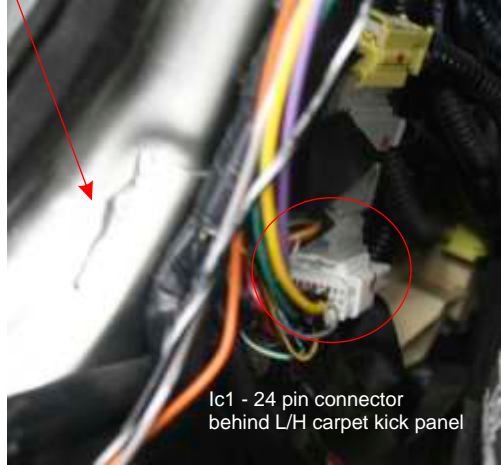

IC1 - 24 pin connector behind L/H carpet kick panel

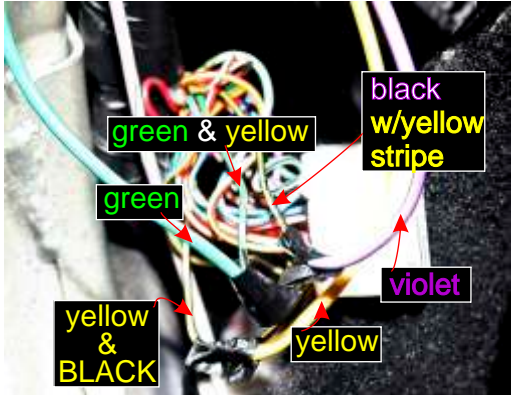
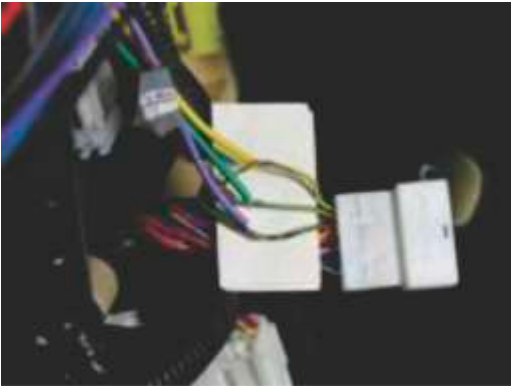

WIRING FROM THE LUXLINK to the DOOR COMPUTER (ECU)

The drivers door interior panel should have already been removed, along with woofer. Carefully peel back the flexible black wire harness boot (between the door frame and the A-Pillar). You will be passing five wires **from the LuxLink wire harness** to connect up with the door ECU.



- First locate the following wires from the LuxLink wire harness:
- Red/White → Position J 1.1
- Brown → Position J 1.5
- Orange → Position J 1.7
- Gray → Position J 1.10
- White → Position J 1.16

- Now using a fishing wire, pass it through the body frame and tape the five wire to it. Pull the wires through the body.

- Next, working from inside the door, pass the fishing wire from inside the door, through the boot, and tape the five wire to it. Pull the wires through the boot, and the door making sure the wire will not interfere with the window as it moves up and down. One suggestion is to pass it through one of the holes used by a clip to hold the interior panel.



WIRING FROM THE LUX LINK to the DOOR COMPUTER (ECU) continued.

Next, remove the electrical tape from around large group of wires. **Now locate and test for the proper wires** from the door ECU and connect. Then strip about a ¼ inch of insulation from all five wires **from the LuxLink harness and once located from the car's DOOR ECU wire harness.**

(See Photos)

1. Attach **brown wire from the Lux Link** to blue with red stripe power door lock wire. (Power when locking door)
2. Attach **gray wire from LuxLink** to blue with black power door unlock wire. (Power when unlocking door)
3. Attach **red with white stripe wire from Lux Link** to red with white stripe door courtesy switch. (Ground with drivers door open)
4. Attach **orange wire from LuxLink** to green power window down wire. (Power with drivers window down)
5. Attach **white wire from LuxLink** to blue power window up wire. (Power with drivers window up)

All wire will be soldered after testing. Then install electrical tape on all five wires individually and the wire harness covering. Then reinstall the door panel and its components.



testing for the correct wires by operating the circuit



After locating the correct wires in the ECU wire harness, carefully strip about a quarter inch of the insulation off the wire. Try not to cut through the wires. You will be twisting on the wires from the Lux Link and then soldering once testing is complete.



Parking Brake Wire

INSTALLING PARKING BRAKE WIRE

Locate skid control ECU under drivers side kick panel next to brake pedal assembly.

Locate the ECU's connector B pin 8 Red with Black wire. Connect the Brown wire **from the Lux Link** (position J1.2) to Red with Black wire. After testing, solder and tape the connection..

LOCATE IGNITION SWITCH CONNECTOR (located under driver's side dash)

- Disconnect 8 pin white ignition switch connector.
- Connect LuxLink "T" connector harness between male and female ignition connectors.

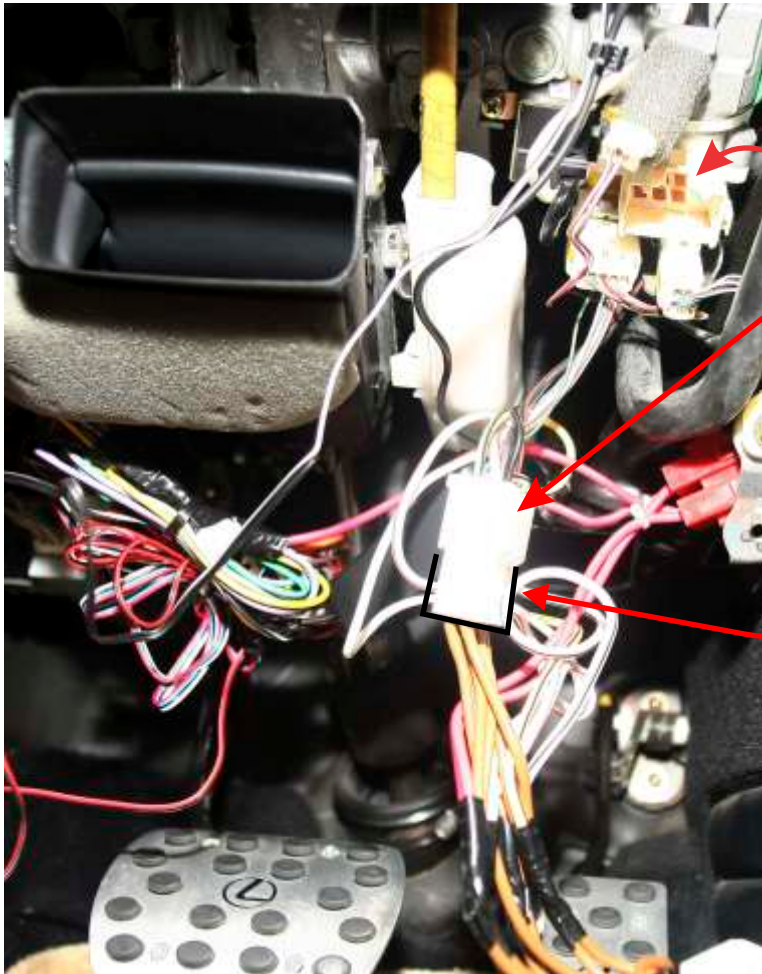

White eight pin ignition connector.
shown disconnected and hanging.

Connect to Lux Link "T" connector

Then take the other end, or male
end of the "T" connector and
reconnected it to the ignition
switch.

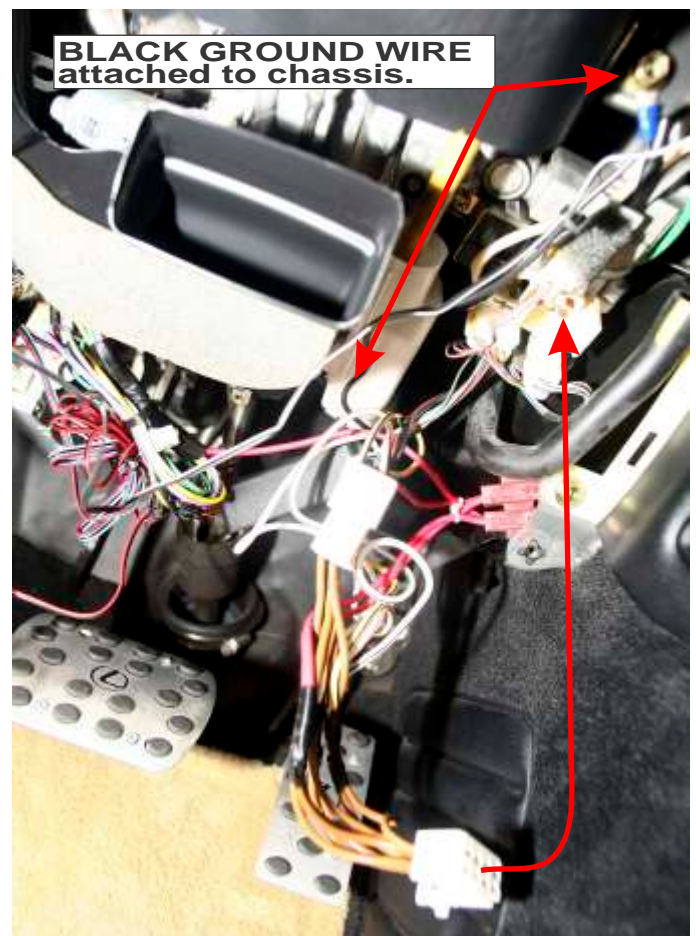

BLACK GROUND WIRE
attached to chassis.

LOCATE AND INSTALL GROUND FROM LUXLINK

- Locate black wire from LuxLink and attach to ground.
- Install ground on known good chassis ground.
- Failure to provide a good ground could result in abnormal operation from LuxLink.

INSTALLATION OF REAR QUARTER WINDOW CONTROL MODULE



Accessing the window regulators for installation of the rear window module is not to difficult.

Begin by pulling up the rear seat cushion about center front of each seat area. The cushion is all in one piece. To get the back panel of the seat cushion off you have to remove the headrest assembly, including the plexiglass windscreen. Start by prying off the back plate which is held on by two claws and two pivot clips. Remove the two 10mm bolts holding windscreen. Then the two anodized nuts on the screw posts. The headrest pulls apart giving you access to two nuts on screw posts underneath them holding the back seat panel in place. There are also two more bolts at the bottom of the seat back, revealed when you pulled out



Removing the interior rear quarter panel to access the speakers and window regulator wiring requires the removal of two (2) hidden screws and one retaining clip. In this photo the one screw (red circle) and the clip (yellow circle) have been removed.

To access them you need to open the top and stop it when the package shelf reaches its highest point and retracts the side panel. This exposes the screw and clip so you can remove them.

You must also remove four 10mm bolts/screws which were hidden under the back seat panel.



Four white clips parallel the B pillar and retain the quarter panel against the body. These clips pop out pretty easily.



The last hidden screw is behind the seat belt slot in the panel. The slot garnish has four retaining claws two top and two on the bottom along with one guide. Carefully using a taped pry tool you can release the claw and gain access to the screw.

Once all the retraining screws and clips are removed or released, the panel pulls up and out with the seatbelt slack.



This shows the location of the two screw posts under the head rests and two bolt locations behind the bottom seat cushion. It also shows the four 10mm screws hidden under the seat back cushion.

Of course all of this is predicated by first removing, by popping off the retaining clips on the interior lighted door sill. Be careful not to pull up too hard due to the wire harness connecting the LEXUS logo sill light.



After getting the rear seats and quarter panels out, you need to find the connector and cable to the window regulator. Now looking at the rear seat driver's side seatbelt anchor. You should see a wire connector with red/green wires. As shown in the inset. It is clipped to the trunk wall. Peel back the brown wiring cover, and cut the wires. Leave yourself plenty of room to make new connections on each side, which you will solder **but only after all function are tested.**



INSTALLATION OF REAR QUARTER WINDOW CONTROL MODULE

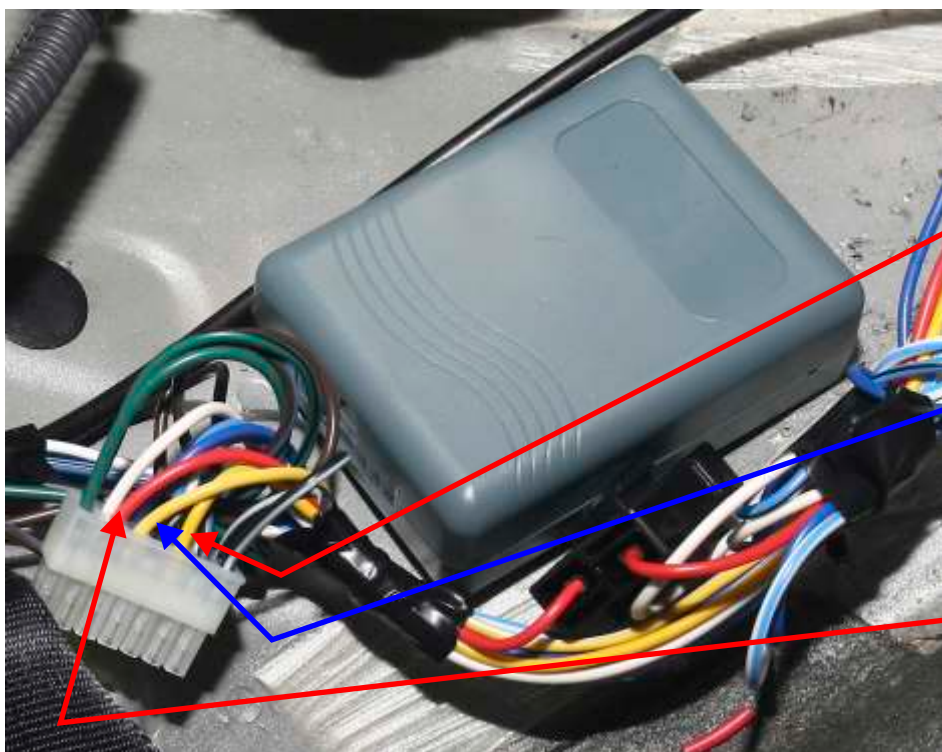
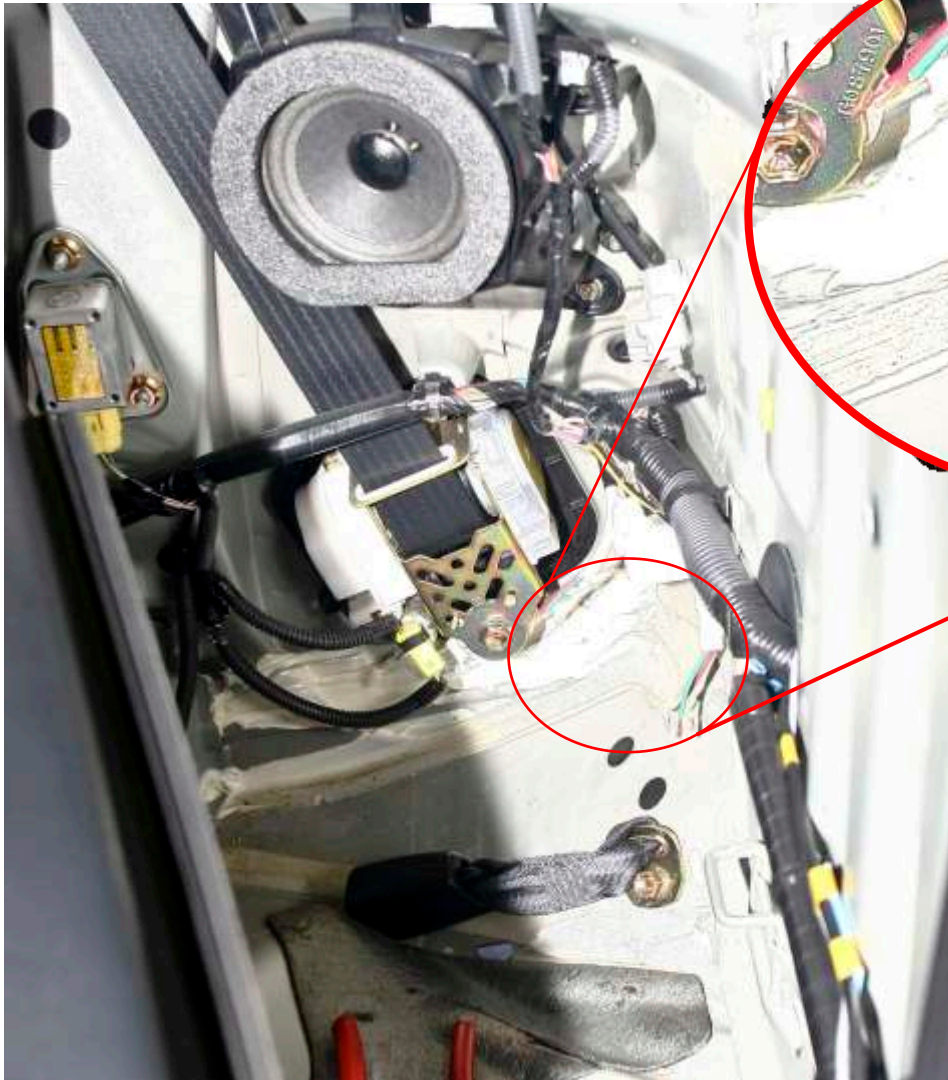

Two wires from the Lux Link wire harness are connected to the Rear Window Module.

The Lux Link's GRAY wire with the WHITE stripe get connected to the rear window control module's YELLOW wire.

The Lux Link's BLACK wire with the WHITE stripe is connected to rear window control module's YELLOW wire with the WHITE STRIPE

The RED wire from the rear window control module runs from the module mounted underneath the back seat to 12v power source on the Lux Link. A spade needs to be attached to the connecting end of the RED wire.

INSTALLATION OF REAR QUARTER WINDOW CONTROL MODULE



Black ground wire from Rear Window module wire harness.



INSTALLATION OF REAR QUARTER WINDOW CONTROL MODULE PASSENGER SIDE Switch - Motor WIRE SPLICE

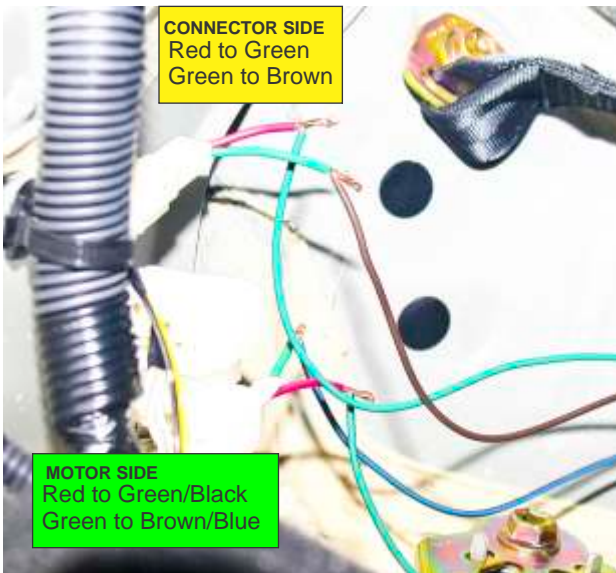

CONNECTOR SIDE
Red to Green
Green to Brown

MOTOR SIDE
Red to Green/Black
Green to Brown/Blue

After cutting the wire past the connector and before the motor you reconnect them using the follow wires from the rear window control module wire harness.

Rear Passenger Window -

Connector side:

Splice the RED wire from the connector to GREEN wire from rear window control module.
Splice the GREEN wire from the connector to BROWN wire from the rear window control module harness.

Motor Side:

Splice the RED wire from the connector to GREEN wire with the BLACK stripe from rear window control module.
Splice the GREEN wire from the connector to BROWN

INSTALLATION OF REAR QUARTER WINDOW CONTROL MODULE

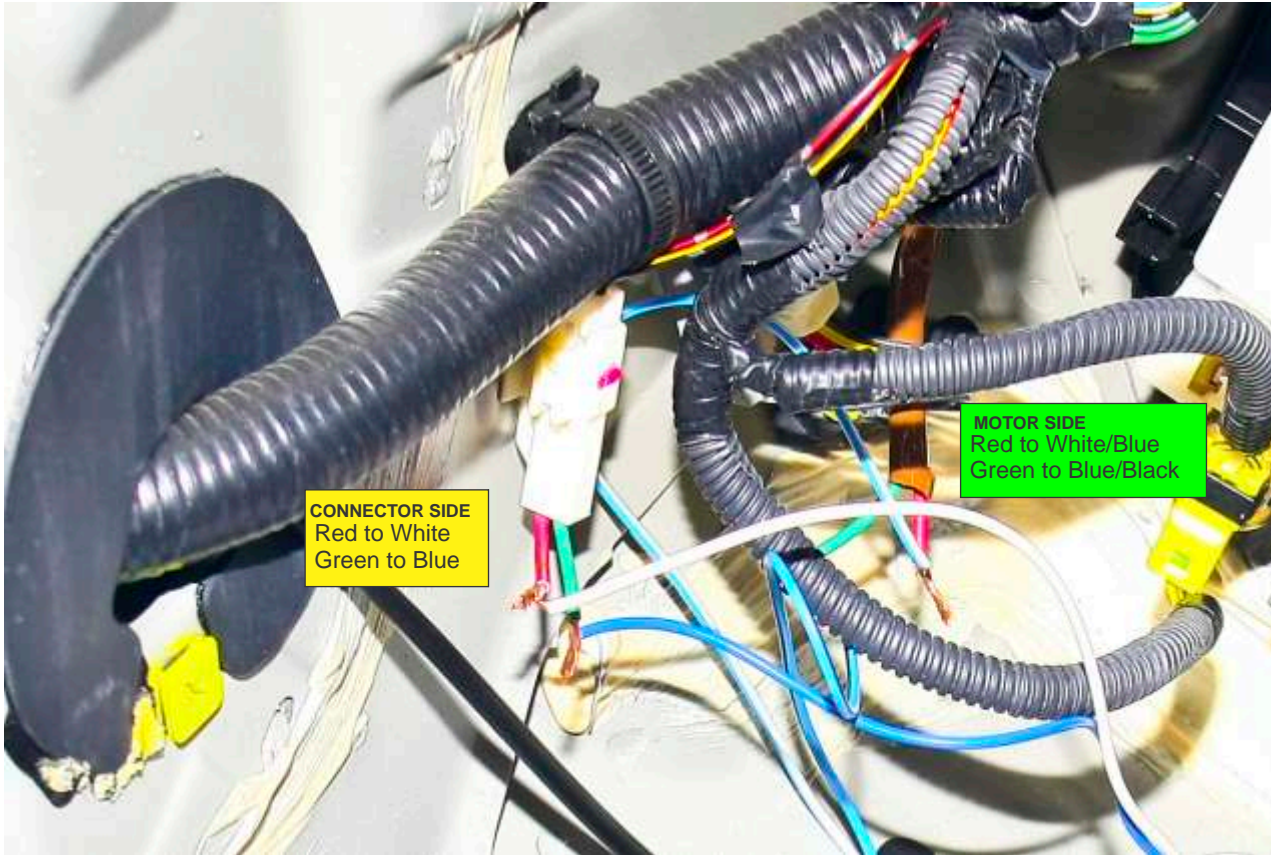

After cutting the wire past the connector and before the motor you reconnect them using the follow wires from the rear window control module wire harness.

Rear Driver's side Quarter Window -

Connector side:

Splice the RED wire from the connector to WHITE wire from rear window control module.
Splice the GREEN wire from the connector to BLUE wire from the rear window control module harness.

Motor Side:

Splice the RED wire from the connector to WHITE wire with the BLUE stripe from rear window control module.
Splice the GREEN wire from the connector to BLUE wire with BLACK stripe from the rear window control module harness.



 The Black wire with white stripe and white wire with black stripe are not used with the Lux Link.