

Vehicle: Electrical Diagrams Navigation System

LEXUS Navigation System

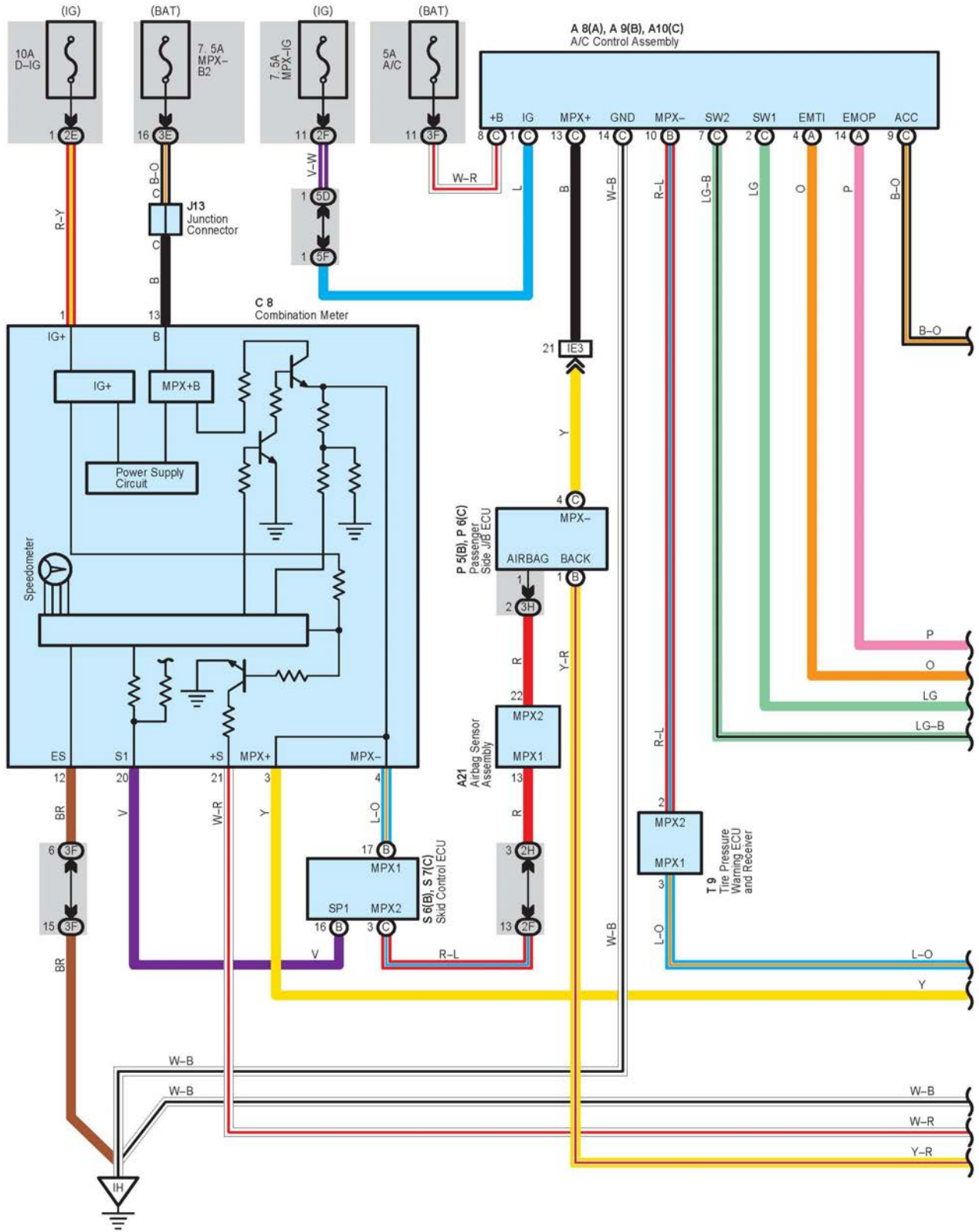

LEXUS Navigation System

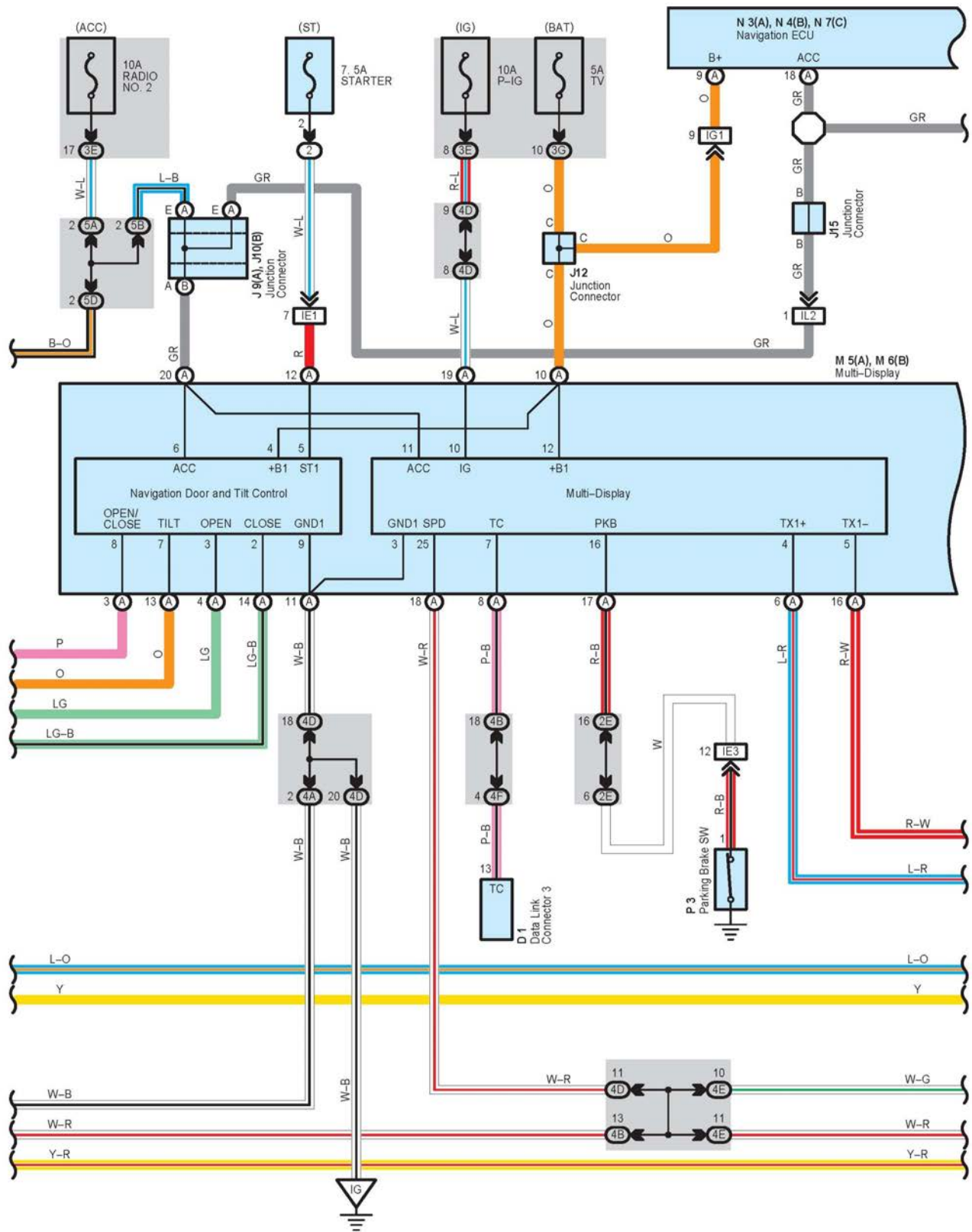

LEXUS Navigation System Part 2

LEXUS Navigation System

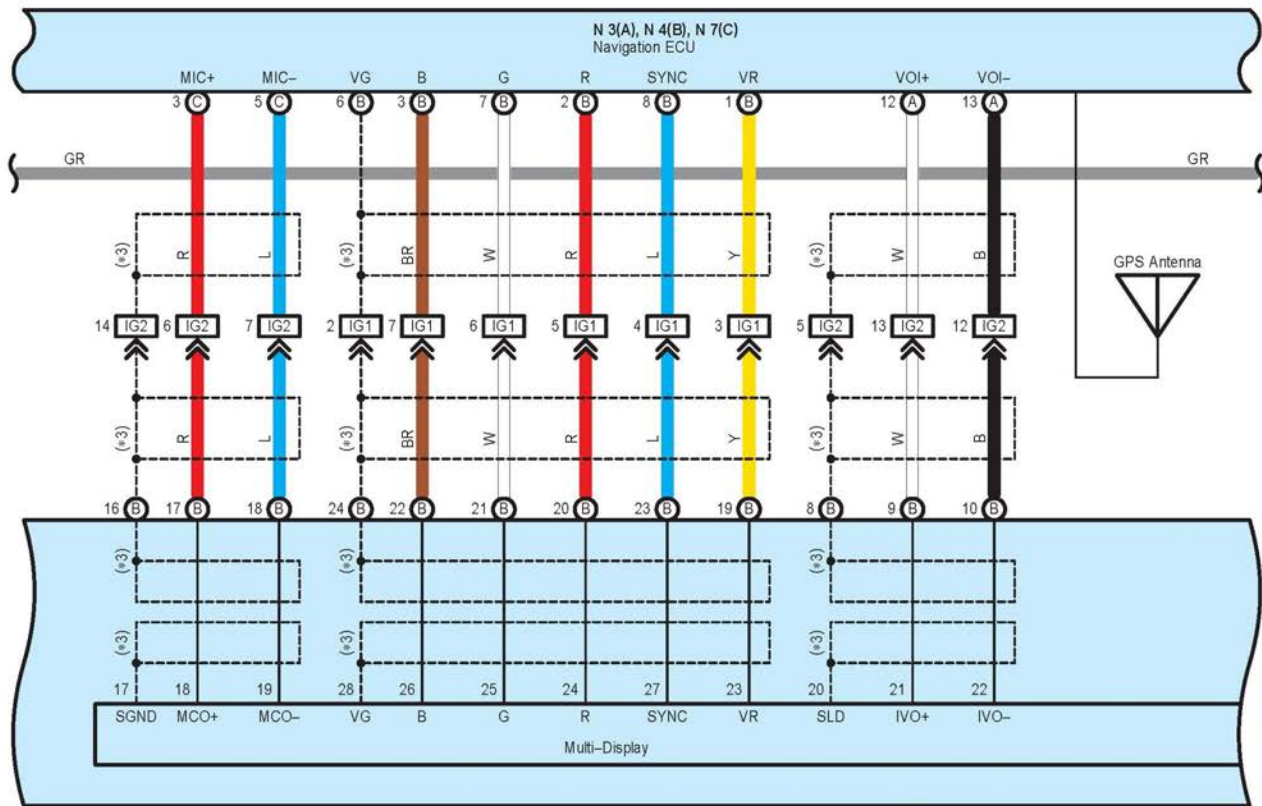

M 5(A), M 6(B)
Multi-Display

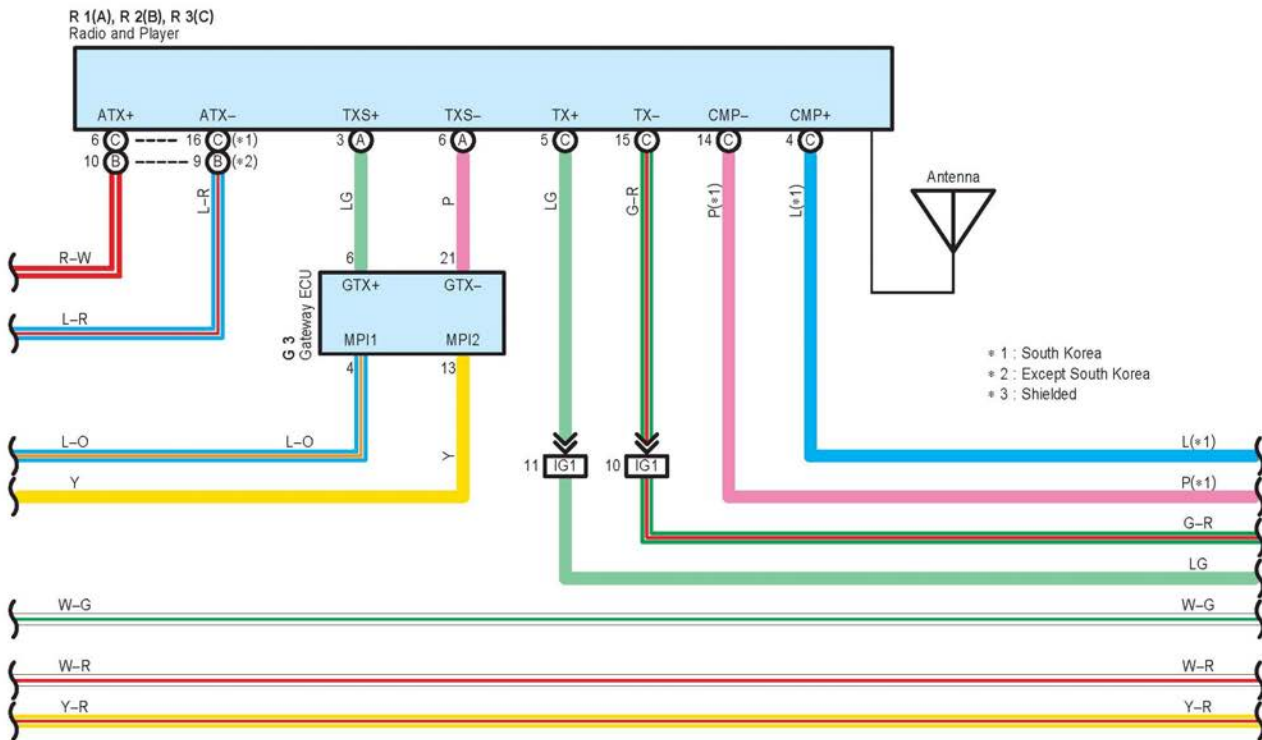

- * 1: South Korea
- * 2: Except South Korea
- * 3: Shielded

LEXUS Navigation System

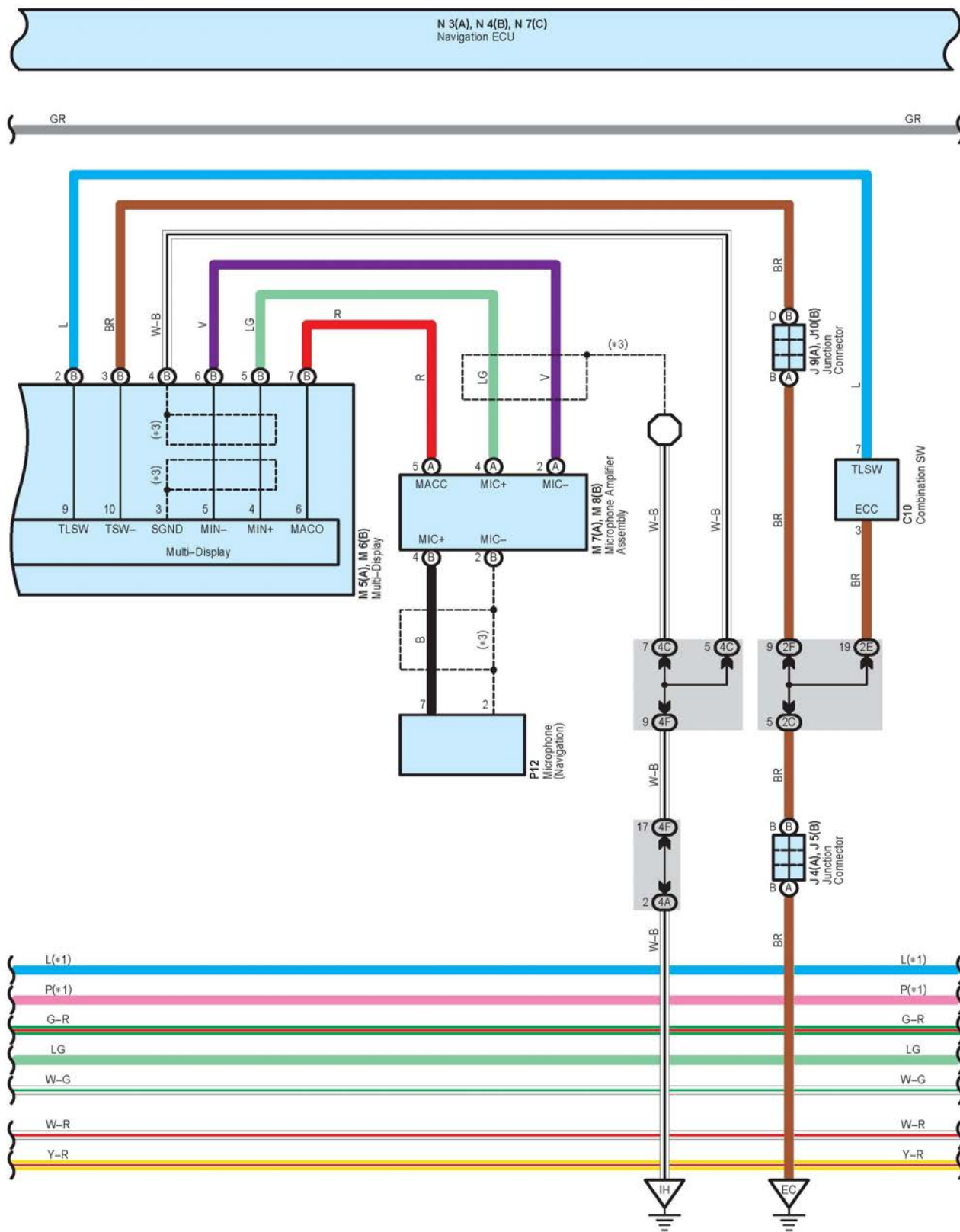

LEXUS Navigation System Part 4

LEXUS Navigation System

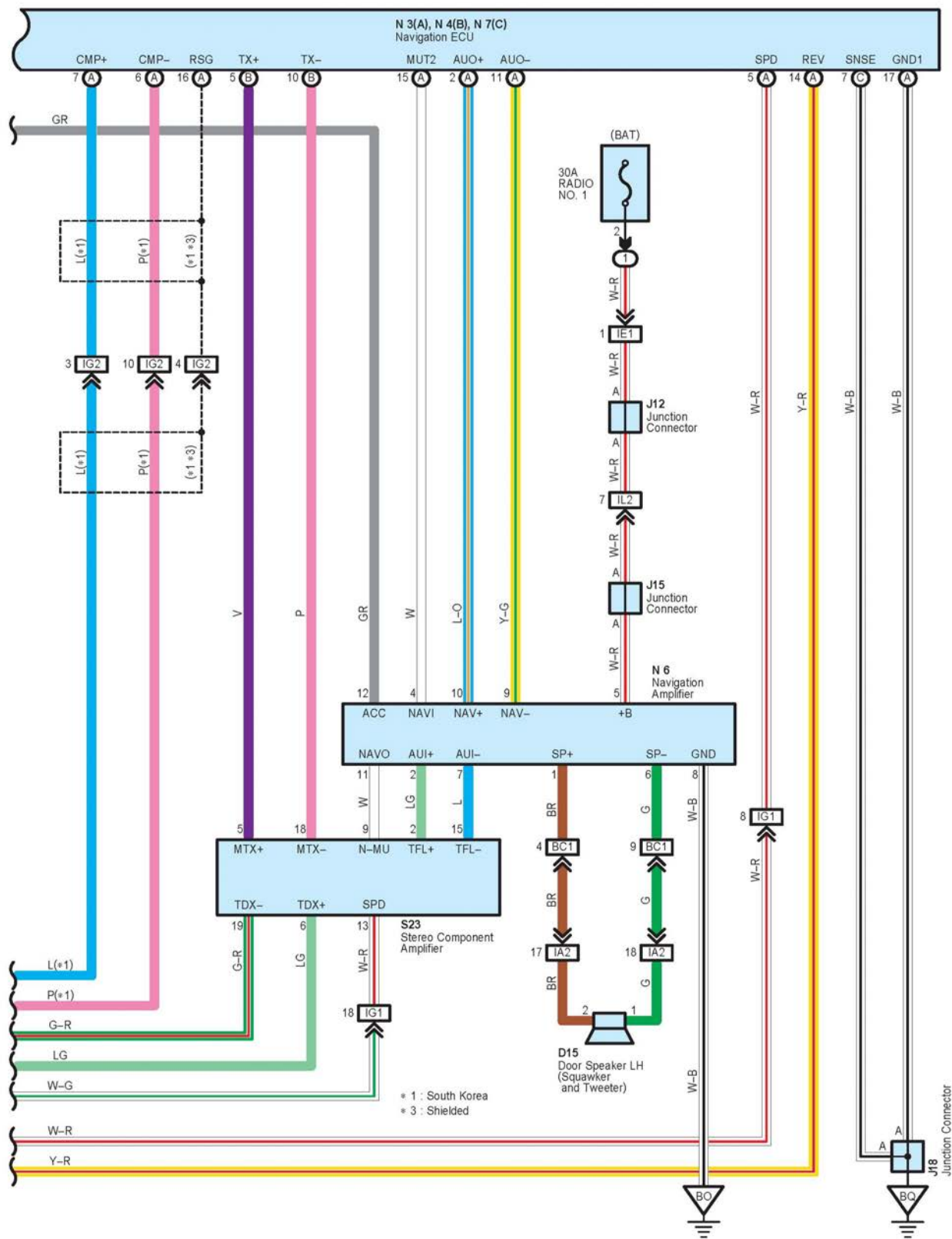

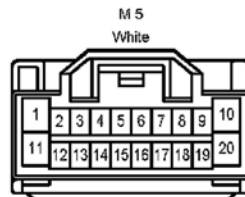
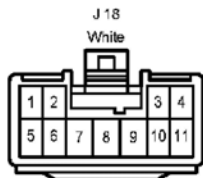
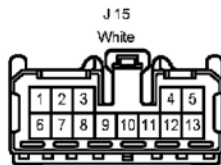
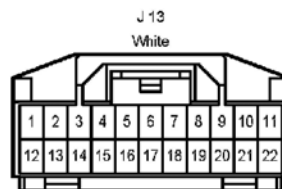
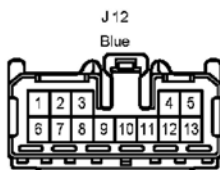
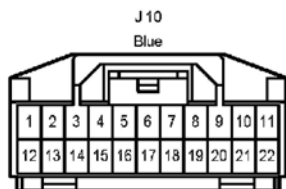
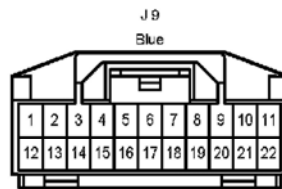
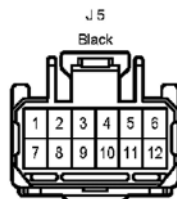
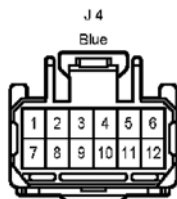
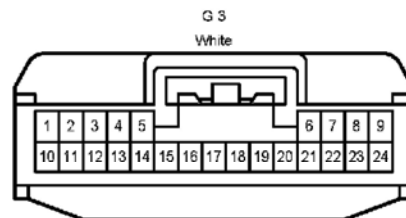
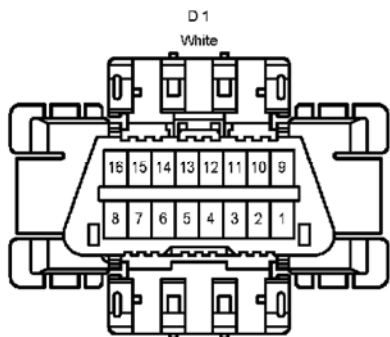
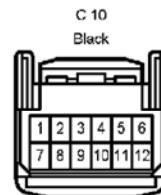
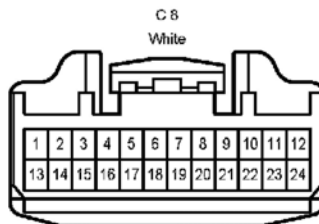
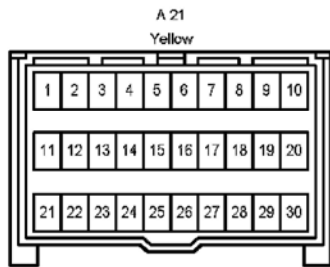
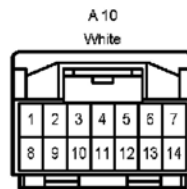
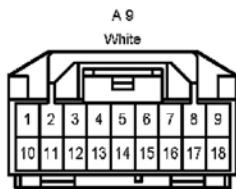
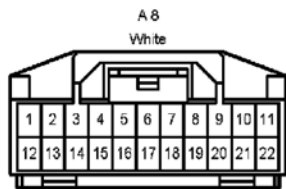

Connector Pin Outs Part 1

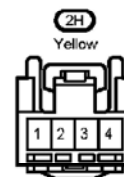
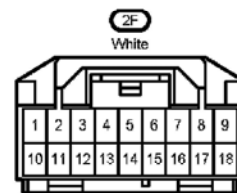
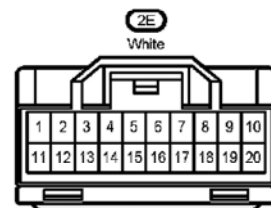
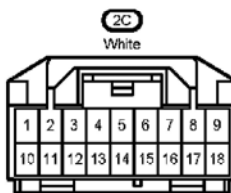
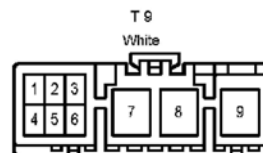
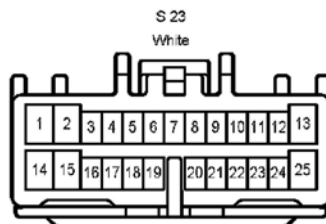
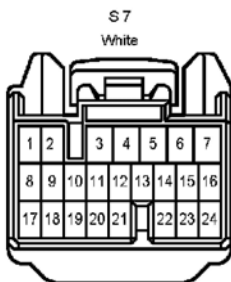
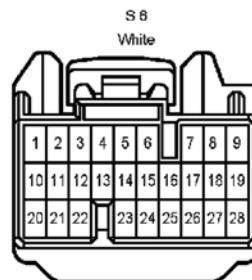
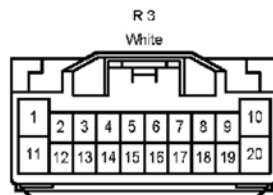
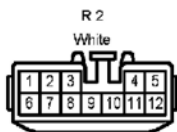
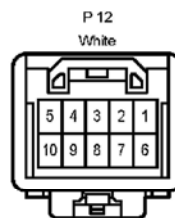
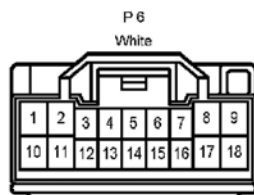
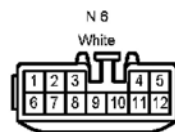
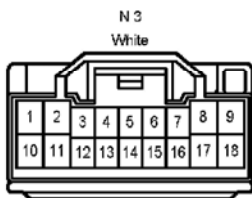
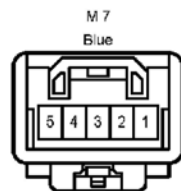
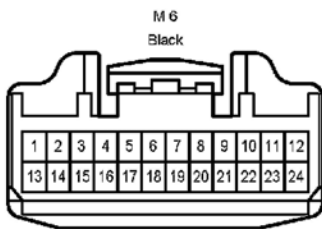

Connector Pin Outs Part 2

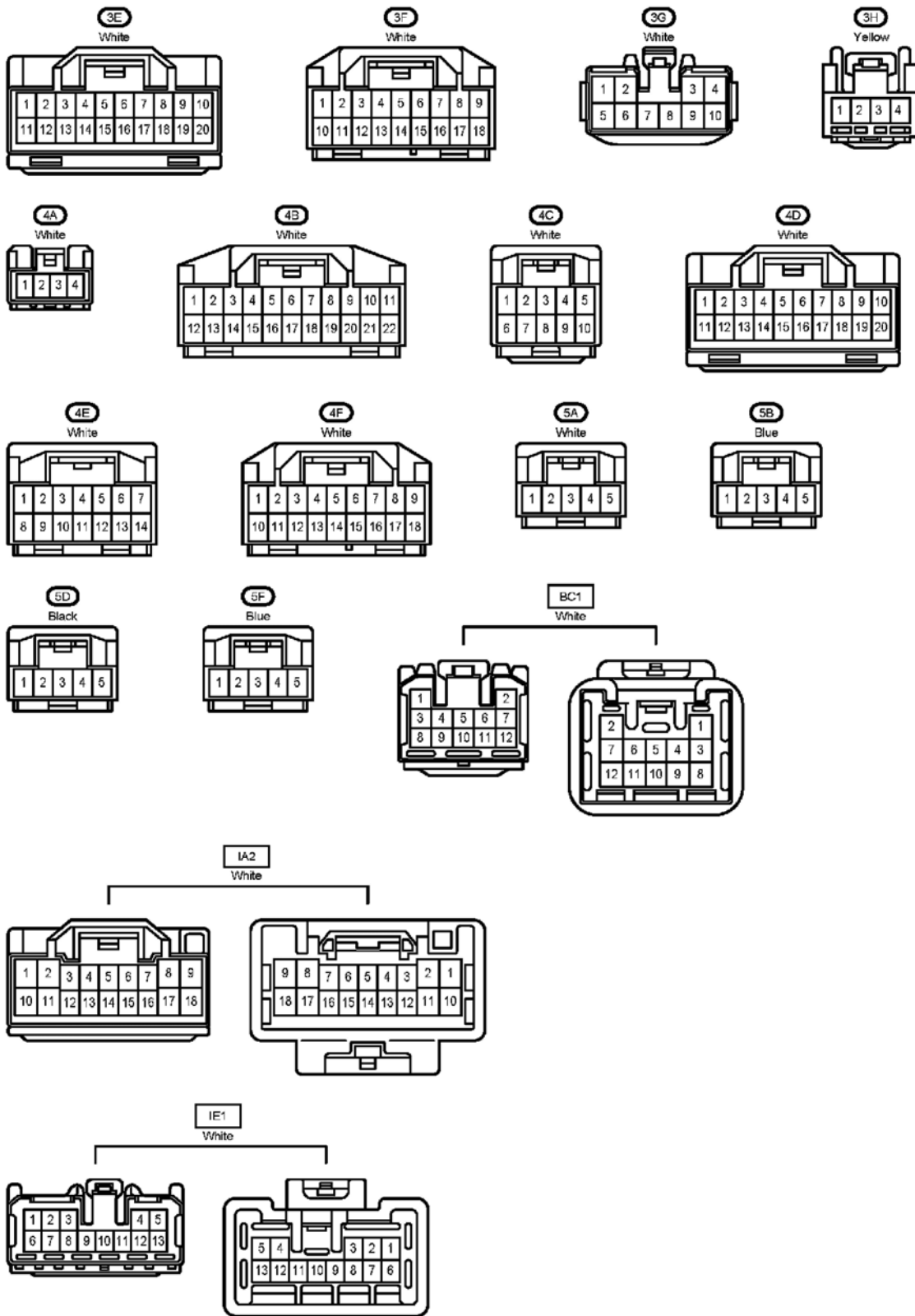

Connector Pin Outs Part 3

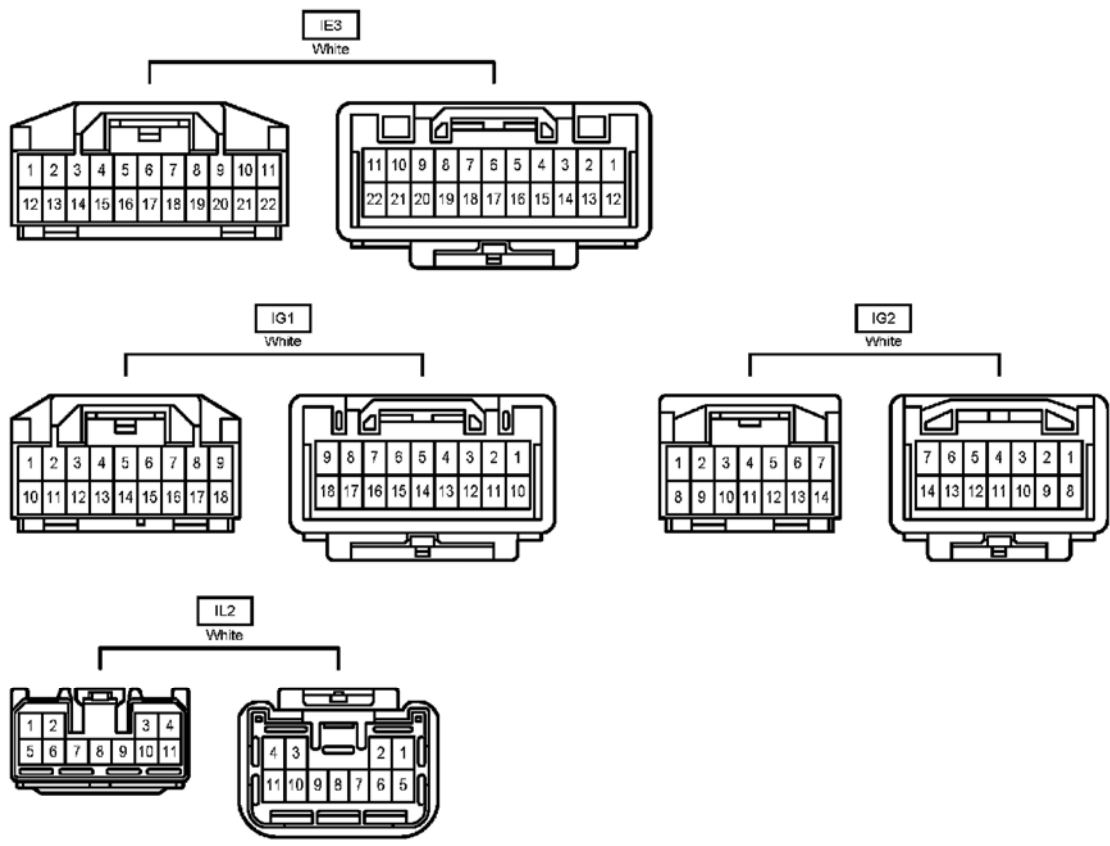

Connector Pin Outs Part 4

Locations: The locations of components, connectors, ground points, and splices referred to within these diagrams can be found at Vehicle Locations. See: Locations