

Service Manual

Pioneer
TOYOTA

ORDER NO.
CRT2585

LEXUS SC430 **AUDIO SYSTEM** **HEAD UNIT**

VEHICLE	DESTINATION	PRODUCED AFTER	TOYOTA PART No.	ID No.	PIONEER MODEL No.
LEXUS SC430	EUROPE	April 2001	86120-24420	P3905	FX-MG8156ZT/EW
LEXUS SC430	EUROPE	April 2001	86120-24420	P3905	FX-MG8156ZT-91/EW
LEXUS SC430	EUROPE	April 2001	86120-24400	P3904	FX-MG8317ZT/EW
LEXUS SC430	EUROPE	April 2001	86120-24400	P3904	FX-MG8317ZT-91/EW

Manufactured for TOYOTA
by PIONEER CORPORATION

PUB. NO. **CRT2585**

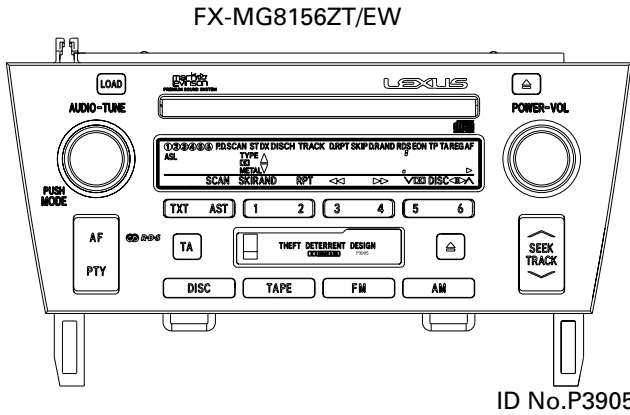

ID No.P3905

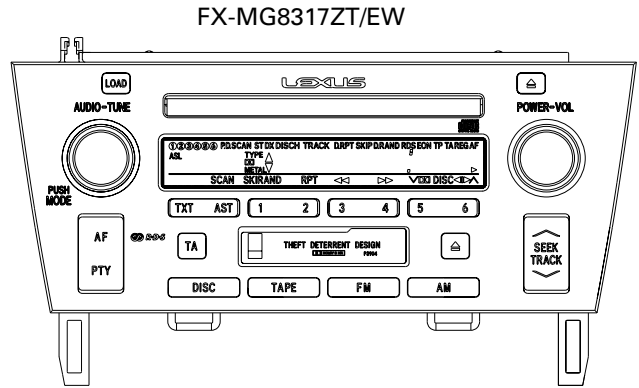

ID No.P3904

● **When the Repair is Complete**

When the repair is complete, make the CD mechanism ready for transportation.

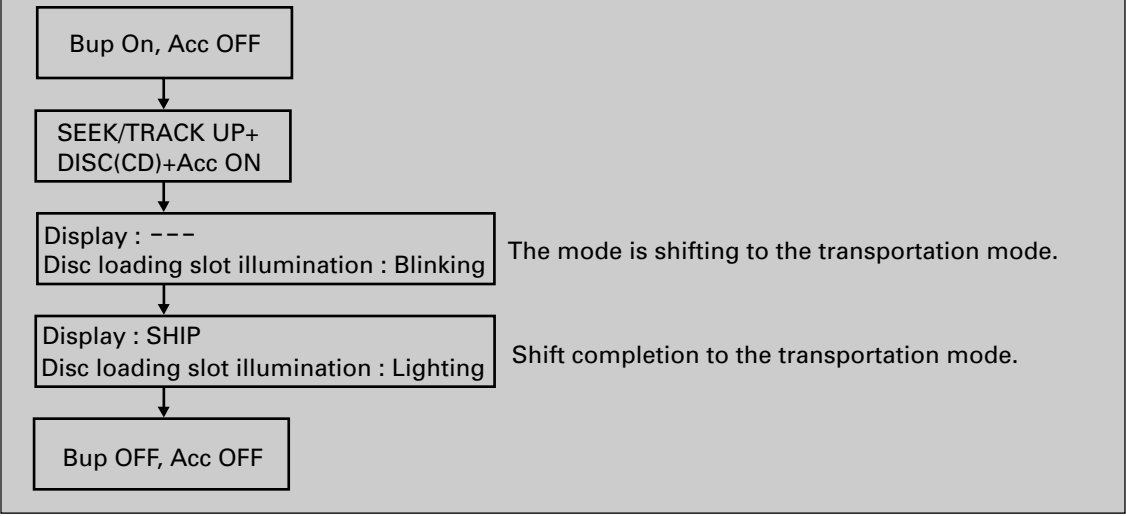

● This service manual should be used together with the following manual(s):

Model No.	Order No.	Mech. Module	Remarks
CX-631	CRT1640	2L	Cassette Mech. Module:Mech.Description, Disassembly
CX-890	CRT2376	G1	CD Mech. Module:Circuit Description, Mech.Description, Disassembly

● **Dolby noise reduction manufactured under license from Dolby Laboratories Licensing Corporation.**

"Dolby" and the double-D symbol are trademarks of Dolby Laboratories Licensing Corporation.

● **See the page 81 of service manual FX-MG9006ZT/EW(CRT2539) for the SELF-DIAGNOSTIC FUNCTION.**

● **Supplementary model is identical to the original except for the addition of following items.**

Description	Part No.	
	FX-MG8156ZT-91/EW	FX-MG8317ZT-91/EW
Polyethylene Bag	CEG1026	CEG1026
Carton	CHA3117	CHA3117
Contain Box	CHD3117	CHD3117
Protector	CHP2408	CHP2408
Protector	CHP2409	CHP2409
Protector	CHP2410	CHP2410
Protector	CHP2411	CHP2411
Protector	CHP2412	CHP2412

CONTENTS

1. SAFETY INFORMATION	3	7.1.3 PCB LOCATIONS	88
2. EXPLODED VIEWS AND PARTS LIST	4	7.1.4 CONNECTOR FUNCTION DESCRIPTION	89
3. BLOCK DIAGRAM AND SCHEMATIC DIAGRAM ...	12	7.2 PARTS	90
4. PCB CONNECTION DIAGRAM	36	7.2.1 IC	90
5. ELECTRICAL PARTS LIST	60	7.2.2 DISPLAY	94
6. ADJUSTMENT	70	7.3 EXPLANATION	95
7. GENERAL INFORMATION	76	7.3.1 SYSTEM BLOCK DIAGRAM	95
7.1 DIAGNOSIS	76	7.3.2 OPERATIONAL FLOW CHART	96
7.1.1 TEST MODE	76	8. OPERATIONS AND SPECIFICATIONS	97
7.1.2 DISASSEMBLY	83		

● CD Player Service Precautions

1. Never attempt to turn on this unit when the CD drive mechanism is upside down. Doing so could cause damage or malfunction to the drive mechanism.
2. For pickup unit(CXX1313) handling, please refer to "Disassembly"(see page 83).
During replacement, handling precautions shall be taken to prevent an electrostatic discharge(Protection by a short pin).
3. During disassembly, be sure to turn the power off since an internal IC might be destroyed when a connector is plugged or unplugged.
4. Please check the grating after changing the service pickup unit(see page 74).

1. SAFETY INFORMATION

This service manual is intended for qualified service technicians; it is not meant for the casual do-it-yourselfer. Qualified technicians have the necessary test equipment and tools, and have been trained to properly and safely repair complex products such as those covered by this manual. Improperly performed repairs can adversely affect the safety and reliability of the product and may void the warranty. If you are not qualified to perform the repair of this product properly and safely; you should not risk trying to do so and refer the repair to a qualified service technician.

1. Safety Precautions for those who Service this Unit.

- When checking or adjusting the emitting power of the laser diode exercise caution in order to get safe, reliable results.

Caution:

1. During repair or tests, minimum distance of 13cm from the focus lens must be kept.
2. During repair or tests, do not view laser beam for 10 seconds or longer.
2. A "CLASS 1 LASER PRODUCT" label is affixed to the bottom of the player.
3. The triangular label is attached to the mechanism unit holder.



4. Specifications of Laser Diode

Specifications of laser radiation fields to which human access is possible during service.

Wavelength = 800 nanometers



2. EXPLODED VIEWS AND PARTS LIST

2.1 EXTERIOR

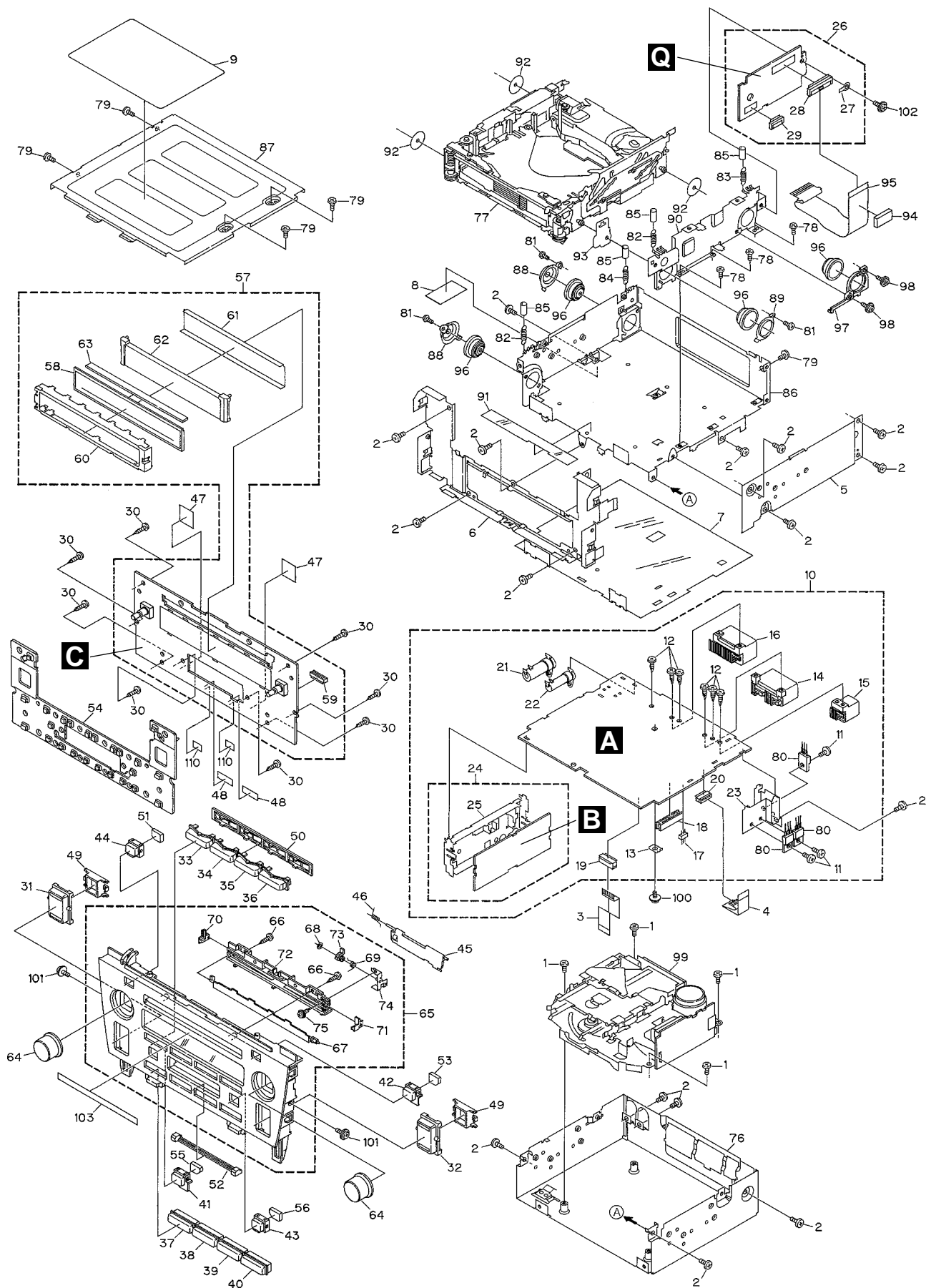

NOTE:

- Parts marked by "*" are generally unavailable because they are not in our Master Spare Parts List.
- Screws adjacent to ∇ mark on the product are used for disassembly.

(1) EXTERIOR SECTION PARTS LIST

Mark No.	Description	Part No.	Mark No.	Description	Part No.
1	Screw	BMZ26P040FMC	46	Spring	CBH2435
2	Screw	BMZ30P050FMC	47	Seal	CNM7027
3	Connector	CDE6448	48	Seal	CNM7028
4	Connector	CDE6509	49	Holder	CNV6106
5	Chassis	CNA2257	50	Holder	CNV6107
6	Frame	CNC8700	51	Lighting Conductor	CNV6108
7	Insulator	CNM6650	52	Lighting Conductor	CNV6109
8	Seal	CNM7286	53	Lighting Conductor	CNV6118
9	Label	CRW1417	54	Rubber	CNV6119
10	Main Unit	CWM7047	55	Lighting Conductor	CNV6126
11	Screw	BMZ30P060FMC	56	Lighting Conductor	CNV6351
12	Screw(M3x6)	CBA1393	57	Keyboard Unit	CWS1333
13	Terminal(CN800)	CKF1059	58	LCD(LCD901)	CAW1691
14	Plug(CN803)	CKM1221	59	Connector(CN902)	CKS4361
15	Connector(CN802)	CKM1315	60	Holder	CNC8672
16	Connector(CN801)	CKM1322	61	Sheet	CNM6620
17	Plug(CN300)	CKS-291	62	Lighting Conductor	CNV6114
18	Connector(CN301)	CKS3568	63	Connector	CNV6115
19	Connector(CN804)	CKS4361	64	Knob Unit	See Contrast table(2)
20	Connector(CN303)	CKS4376	65	Grille Unit	See Contrast table(2)
21	86146-48030(ANT1)	CKX1057	66	Screw	BMZ20P080FMC
22	86146-48040(ANT2)	CKX1058	67	Door	CAT2221
23	Holder	CNC8704	68	Washer	CBF1037
24	FM/AM Tuner Unit	CWE1591	69	Spring	CBH2446
25	Holder	CNC6122	70	Lighting Conductor	CNV6110
26	Control Unit	CWM7280	71	Lighting Conductor	CNV6111
27	Terminal(CN703)	CKF1064	72	Holder	CNV6590
28	Connector(CN701)	CKS3989	73	Gear	CNV6726
29	Connector(CN702)	CKS4376	74	Bracket Unit	CXB6083
30	Screw	BPZ20P080FMC	75	Screw	IMS20P030FMC
31	Button(AF,PTY)	CAC6479	76	Chassis Unit	CXB6477
32	Button(SEEK,TRACK)	CAC6465	77	Mechanism Assy(Service)	CXX1487
33	Button(TXT,AST)	CAC6480	78	Screw	BMZ20P020FMC
34	Button(1,2)	CAC6467	79	Screw	BMZ26P030FMC
35	Button(3,4)	CAC6468	80	Transistor(Q809,811,812)	2SB1185
36	Button(5,6)	CAC6469	81	Screw(M2x2)	CBA1250
37	Button(DISC)	CAC7170	82	Spring	CBH2472
38	Button(TAPE)	CAC7169	83	Spring	CBH2473
39	Button(FM)	CAC7168	84	Spring	CBH2478
40	Button(AM)	CAC7167	85	Tube	CDM1028
41	Button(TA)	CAC6483	86	Chassis	CNA2256
42	Button(CD EJECT)	CAC6482	87	Case	CNB2549
43	Button(TAPE EJECT)	CAC6478	88	Holder	CNC7477
44	Button(LOAD)	CAC6481	89	Holder	CNC7826
45	Door	See Contrast table(2)	90	Holder	CNC8701

FX-MG8156ZT, MG8156ZT-91, MG8317ZT, MG8317ZT-91

Mark No.	Description	Part No.
91	Insulator	CNM5969
92	Sheet	CNM5981
93	Sheet	CNM6318
94	Cushion	CNM7023
95	PCB	CNP5516
96	Damper	CNV5120
97	Holder	CNV5543
98	Screw	IMS20P040FMC
99	Cassette Mechanism Module	EXK3891
100	Screw	IMS26P040FMC
101	Screw	ISS26P060FMC
102	Screw	PMB26P060FMC
103	Label	CRW1420
104-109	
110	Cushion	CNM7439

(2) CONTRAST TABLE

FX-MG8156ZT/EW and FX-MG8317ZT/EW are constructed the same except for the following:

Mark No.	Symbol and Description	Part No.	
		FX-MG8156ZT/EW	FX-MG8317ZT/EW
45	Door	CAT2115	CAT2119
64	Knob Unit	CXB6372	CXB5185
65	Grille Unit	CXB7594	CXB7590

● CD MECHANISM SECTION PARTS LIST

Mark No.	Description	Part No.	Mark No.	Description	Part No.
1-9	●●●●●		59	Gear	CNC7236
10	CD Core Unit(Servo Unit)	CWX2421	60	Gear	CNC9512
11	Connector(CN101)	CKS2764	61	Lever	CNC7243
12	Connector(CN301)	CKS3966	62	Lever	CNC7244
13	Connector(CN201)	CKS3991	63	Lever	CNC7245
14	CD Core Unit(STS Unit)	CWX2422	64	Lever	CXB4944
15	Connector(CN701)	CKS3989	65	Cover	CNC7441
16	Connector(CN801)	CKS3989	66	Holder Unit	CXB4946
17	Connector(CN802)	CKS4054	67	Lever	CNC9088
18	Screw	CBA1037	68	Gear	CNC8140
19	Screw	CBA1041	69	Sheet	CNM6840
20	Screw	CBA1076	70	PCB	CNP5764
21	Screw	CBA1250	71	PCB	CNP6010
22	Washer	CBA1529	72	Gear	CNR1479
23	Screw	CBA1452	73	Gear	CNR1481
24	Screw	CBA1453	74	Gear	CNR1495
25	Screw	CBA1479	75	Gear	CNR1501
26	Washer	CBF1037	76	Gear	CNR1502
27	Washer	CBF1038	77	Gear	CNR1540
28	Washer	CBF1039	78	Gear	CNR1541
29	Washer	CBF1064	79	Belt	CNT1080
30	Spring	CBH2007	80	Worm Gear	CNV5046
31	Spring	CBH2271	81	Gear	CNV5047
32	Spring	CBH2274	82	Gear	CNV5048
33	Spring	CBH2014	83	Gear	CNV5049
34	Spring	CBH2015	84	Holder	CNV5056
35	Spring	CBH2016	85	Pulley	CNV5058
36	Spring	CBH2017	86	Arm	CNV5061
37	Spring	CBH2290	87	Spacer	CNV5066
38	Spring	CBH2366	88	Arm	CNV5189
39	Spring	CBH2064	89	Cover	CNV5207
40	Spring	CBH2195	90	Cover	CNV5424
41	Spring	CBH2196	91	Cover	CNV5425
42	Spring	CBH2224	92	Lever	CNV5427
43	Spring	CBH2250	93	Arm	CNV5491
44	Screw	CBA1082	94	Gear	CNV5519
45	Roller	CLA3154	95	Holder	CNV5648
46	Roller	CLA3157	* 96	Composite PCB	CNX3501
47	Roller	CLA3159	* 97	Composite PCB	CNX3502
48	Roller	CLA3160	98	Chassis Unit	CXB5940
49	Shaft	CLA3179	99	Frame Unit	CXB5806
50	Spacer	CLA3194	100	Lever Unit	CXB6026
51	Roller	CLA3248	101	Arm Unit	CXB2704
52	Bush	CLA3353	102	Lever Unit	CXB2708
* 53	Shaft	CLA3469	103	Lever Unit	CXB2709
54	Shaft	CLA3693	104	Lever Unit	CXB4949
55	Steer	CNC7215	105	Arm Unit	CXB2712
56	Steer	CNC7216	106	Lever Unit	CXB4948
57	Cam	CNC8774	107	Lever Unit	CXB2714
58	Holder	CNC7235	108	Carriage Mechanism Unit(G1)	CXB4941

Mark No.	Description	Part No.	Mark No.	Description	Part No.
109	Screw	CBA1041	159	Screw	CBA1453
110	Screw	CBA1250	160	Washer	CBF1038
111	Screw	CBA1362	161	Loading Arm R Assy(Service)	CXX1486
112	Screw	CBA1471	162	Washer	CBF1074
113	Washer	CBF1038	163	Spring	CBH2136
114	Spring	CBH2008	* 164	Arm	CNC7241
115	Spring	CBH2009	* 165	Arm	CXB6911
116	Spring	CBH2010	166	Holder	CBL1508
117	Spring	CBL1335	167	Belt	CNT1079
118	Roller	CLA3913	168	Holder	CNV5055
* 119	Bracket	CNC7228	169	Pulley	CNV5057
120	Guide Unit	CXB4417	170	Roller	CNV6209
121	Cover	CNC7628	171	Guide	CNV5125
122	Sheet	CNM6414	* 172	Bracket Unit	CXB5937
123	Sheet	CNM5378	173	Roller Gear Unit	CXB3176
124	•••••		* 174	Motor Unit(M2 LOAD)	CXB3177
125	Sheet	CNM5827	175	Screw	JFZ14P020FMC
126	PCB	CNP6164	176	Loading Arm R Assy	CXB5839
127	Ball	CNR1189	177	Screw	CBA1453
128	Bearing	CNR1423	178	Washer	CBF1074
129	Belt	CNT1079	179	Spring	CBH2136
130	Holder	CNV5037	* 180	Arm	CNC7242
131	Guide	CNV5040	* 181	Arm	CXB6912
132	Clamper	CNV5042	182	Screw	JFZ20P014FMC
133	Rack	CNV5111	183	Roller	CNV6209
134	Arm	CNV5579	184	Roller Gear Unit	CXB3176
135	Holder	CNV5759	185	Guide	CNV5126
* 136	Chassis	CXB6025	186	Switch(S885 MAX DETECT)	CSN1052
137	Arm Unit	CXB2705	187	LED(D883)	CL205IRXTU
138	Motor Unit(M4 CARRIAGE)	CXB3178	188	Photo-transistor(Q881)	CPT230SCTD
139	Screw Unit	CXB3179	189	LED(D891,892)	CL205IRXTU
140	Lever Unit	CXB4450	190	Switch(S887 CLAMP)	CSN1051
141	Bracket	CNC8584	191	Switch(S886 ELV HOME)	CSN1052
142	Spacer	CNM6345	192	Bracket Unit	CXB6086
143	Motor(M5 SPINDLE)	CXM1120	193	Photo-transistor(Q851,852)	CPT230SCTD
144	Screw	JFZ14P020FZK	194	Resistor(R856)	RS1/8S911J
145	Washer	YE15FUC	195	Resistor(R857)	RS1/8S821J
146	Arm Unit	CXB6052	196	Photo-interrupter(Q1)	RPI-221
147	Arm Unit	CXB6053	197	Screw	CBA1387
148	Tray Assy	CXB4307	198	Pickup Unit(Service)(P8)	CXX1313
149	Spring	CBH2269	199	Spring	CBL1467
150	Sheet	CNM7109	200-202	•••••	
151	Cam Motor Assy	CXB6928	203	Sheet	CNM7025
152	•••••		204	Inductor(L1,2,801,802)	LCYBR15J1608
* 153	Bracket Unit	CXB5201			
* 154	Motor Unit(M1 Cam Gear)	CXB6929			
* 155	Motor Unit(M3 ELV)	CXB3175			
156	Screw	JFZ20P025FMC			
157	Loading Arm L Assy	CXB6957			
158	Loading Arm L Assy(Service)	CXX1469			

2.3 CASSETTE MECHANISM MODULE

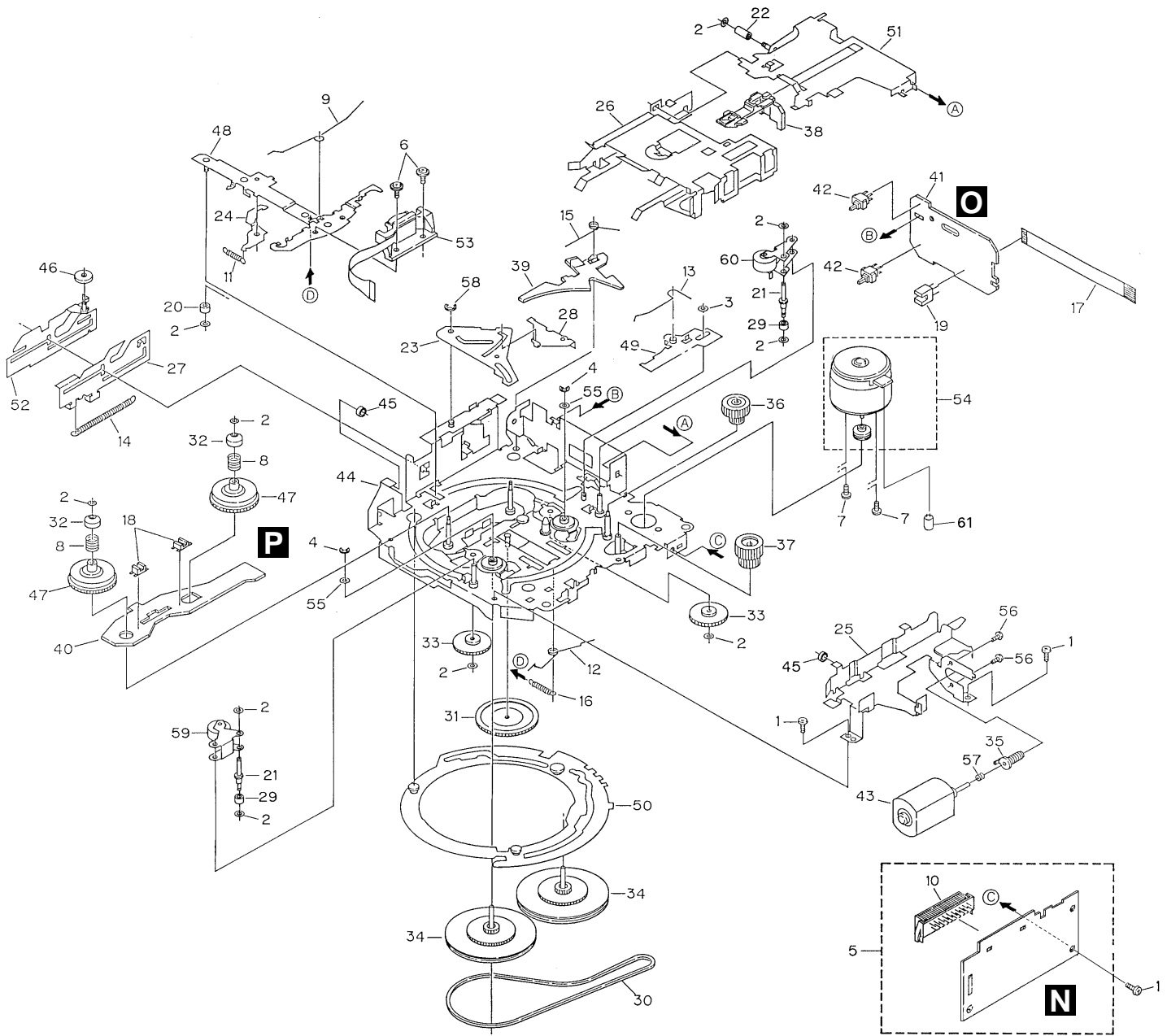

● CASSETTE MECHANISM MODULE SECTION PARTS LIST

Mark No.	Description	Part No.	Mark No.	Description	Part No.
1	Screw	BSZ20P040FMC	31	Gear	ENV1347
2	Washer	CBF1037	32	Collar	ENV1508
3	Washer	CBF1038	33	Gear	ENV1350
4	Washer	CBG1003	34	Flywheel	ENV1500
5	Deck Unit	EWM1030	35	Worm Gear	ENV1439
6	Screw(M2x5)	EBA1028	36	Worm Wheel	ENV1440
7	Screw(M2x2.5)	CBA1037	37	Gear	ENR1037
8	Spring	EBH1531	38	Lever	ENV1533
9	Spring	EBH1589	39	Arm	ENV1525
10	Connector(CN251)	CKS3540	40	Gathering PCB	ENX1037
11	Spring	EBH1515	41	Gathering PCB	ENX1060
12	Spring	EBH1587	42	Switch(S1)(S2)	ESG1004
13	Spring	EBH1517	43	Motor Unit(M2)(SUB)	EXA1382
14	Spring	EBH1518	44	Chassis Unit	EXA1559
15	Spring	EBH1519	45	Tube	ENM1039
16	Spring	EBH1537	46	Roller	ENR1027
17	Cord	EDD1027	47	Reel Unit	EXA1560
18	Photo-interrupter(EGN2,3)	EGN1006	48	Head Base Unit	EXA1434
19	Photo-interrupter(EGN1)	EGN1005	49	Lever Unit	EXA1578
20	Roller	ENR1031	50	Gear Unit	EXA1545
21	Shaft	ELA1362	51	Frame Unit	EXA1476
22	Roller	ELA1348	52	Lever Unit	EXA1439
23	Arm	ENC1490	53	Head Assy(HD1)	EXA1594
24	Arm	ENC1397	54	Motor Unit(M1)(MAIN)	EXA1499
25	Guide	ENC1519	55	Washer	HBF-179
26	Holder	ENC1516	56	Screw	JGZ20P025FNI
27	Lever	ENC1448	57	Spring	EBH1545
28	Arm	ENC1488	58	Washer	YE20FUC
29	Roller	ENR1023	59	Pinch Roller Unit	EXA1533
30	Belt	ENT1027	60	Pinch Roller Unit	EXA1532
			61	Capacitor(C1)	CEAL4R7M35

3. BLOCK DIAGRAM AND SCHEMATIC DIAGRAM

3.1 BLOCK DIAGRAM

A

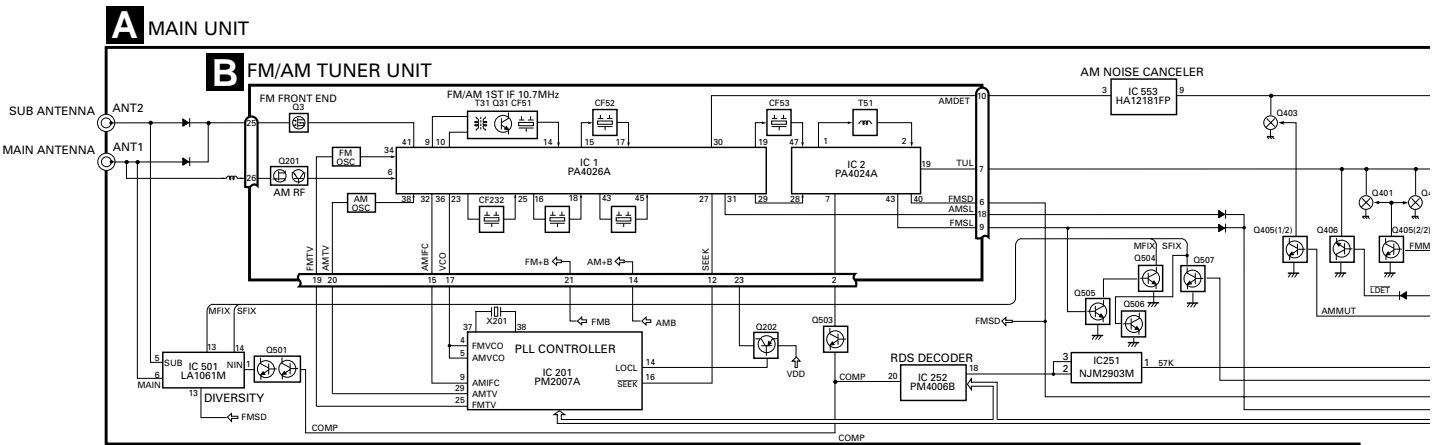

B

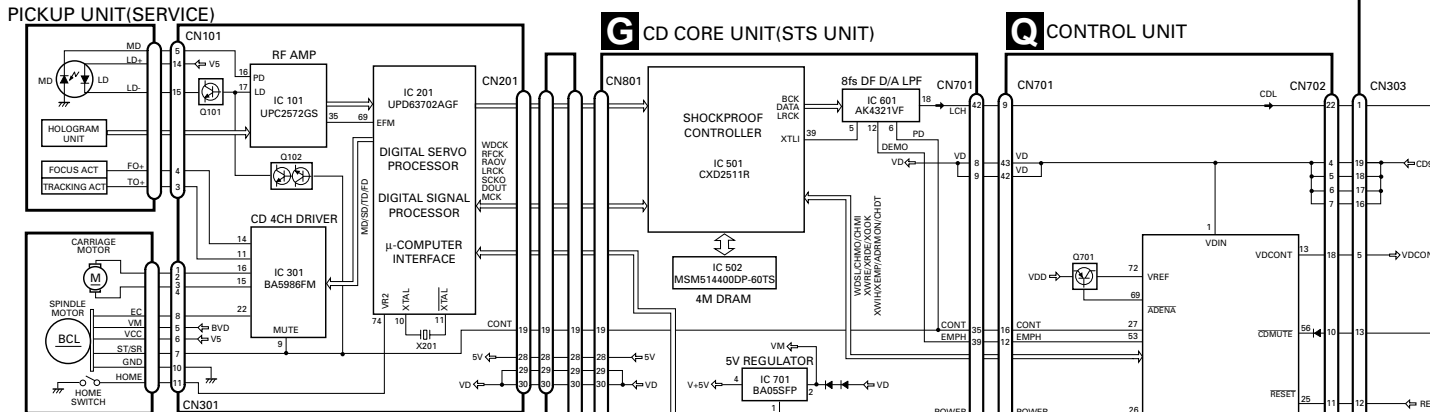

C

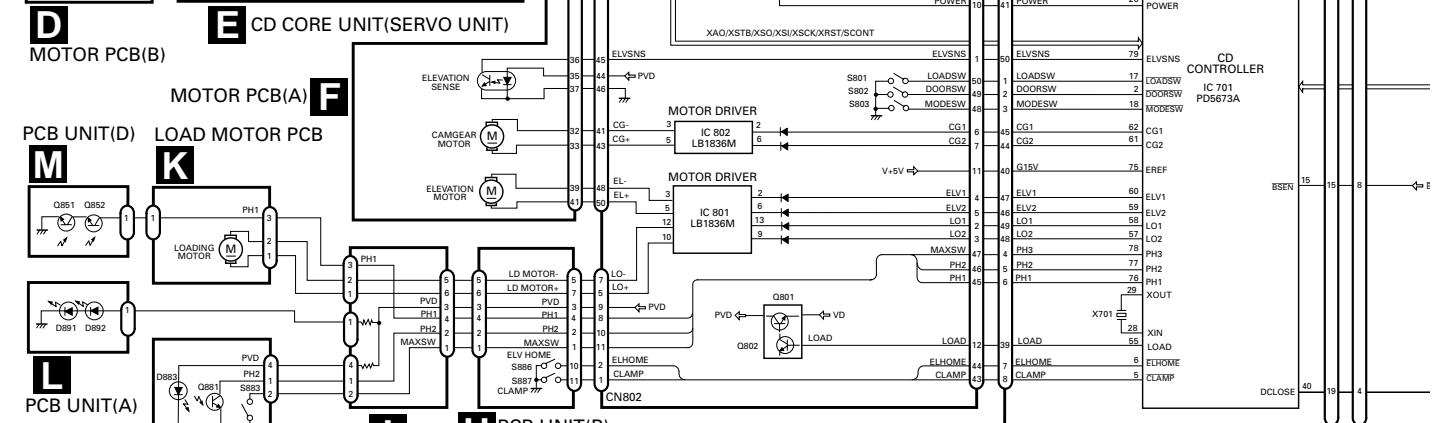

D

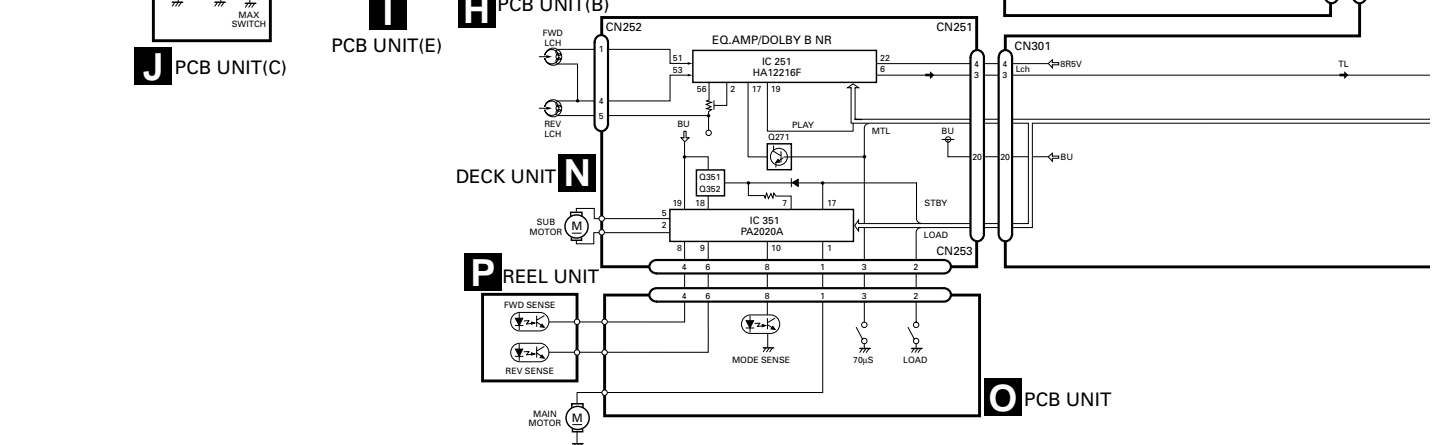

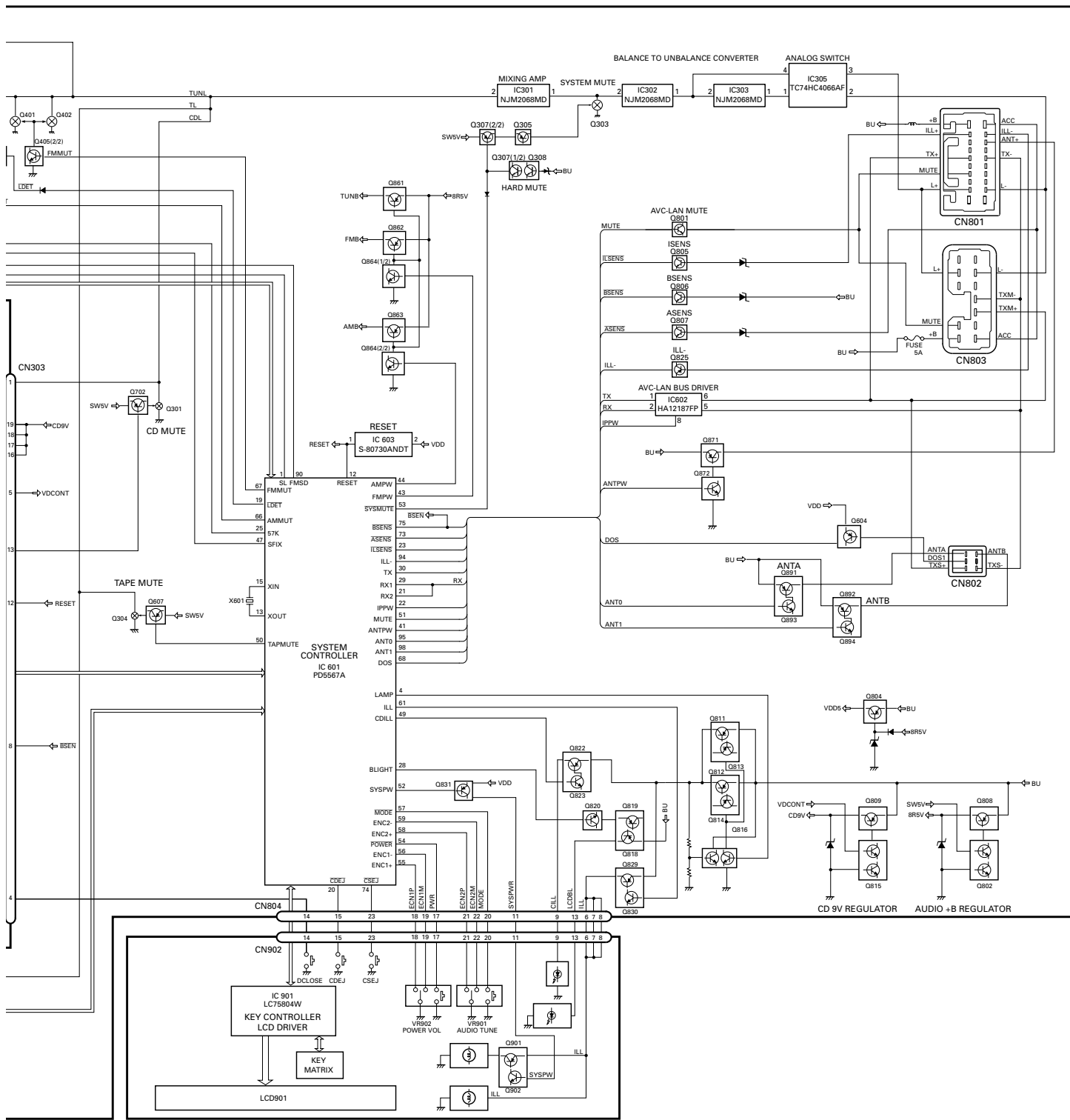

A-b

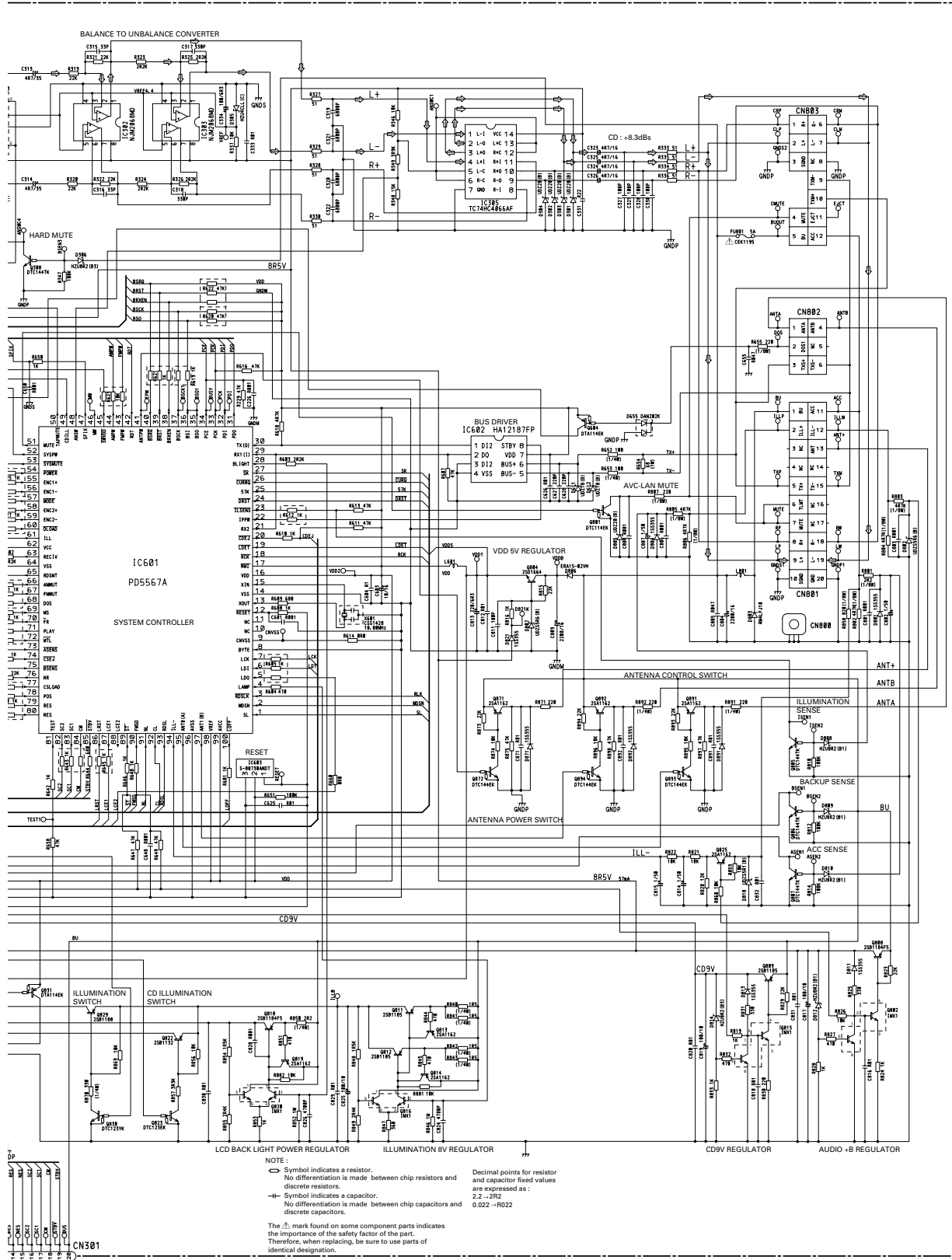

NOTE

- ⊖ Symbol indicates a resistor. No differentiation is made between chip resistors and discrete resistors.
- ⊕ Symbol indicates a capacitor. No differentiation is made between chip capacitors and discrete capacitors.

The Δ mark found on some component parts indicates the importance of the safety factor of the part. Therefore, when replacing, be sure to use parts of identical designation.

Decimal points for resistor and capacitor fixed values are expressed as:
 2.2 → 2R2
 0.022 → R022

A
B
C
D



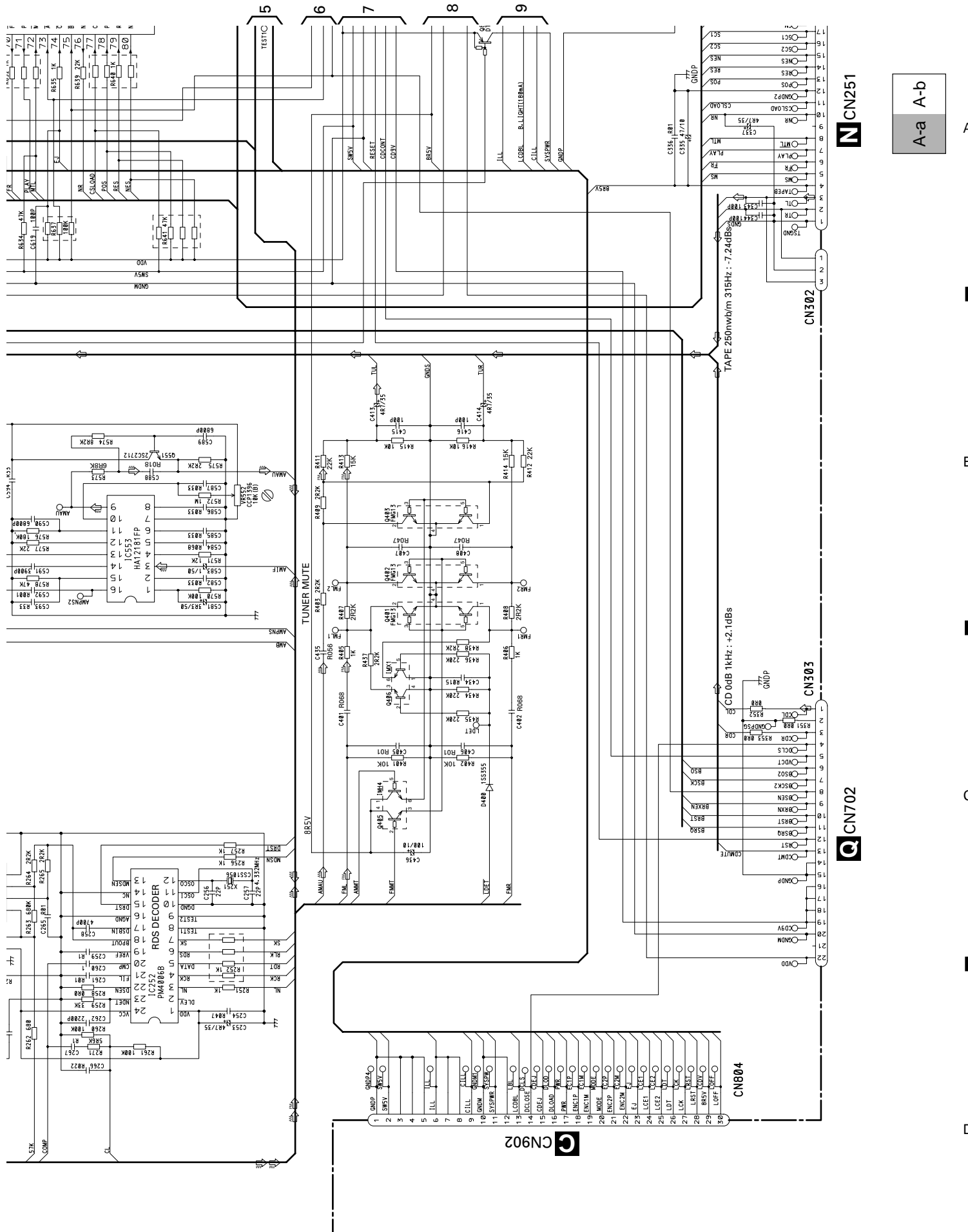

A-a A-b

Q CN251

CN302

CN303

CN702

CN604

CN902

CN302

CN303

CN702

CN604

CN902

CN302

CN303

CN702

CN604

CN902

CN302

CN303

CN702

CN604

CN902

CN302

CN303

CN702

CN604

CN902

CN302

CN303

CN702

CN604

CN902

CN302

CN303

CN702

CN604

CN902

CN302

CN303

CN702

CN604

CN902

CN302

CN303

CN702

CN604

CN902

CN302

CN303

CN702

CN604

CN902

CN302

CN303

CN702

CN604

CN902

CN302

CN303

CN702

CN604

CN902

CN302

CN303

CN702

CN604

CN902

CN302

CN303

CN702

CN604

CN902

CN302

CN303

CN702

CN604

CN902

CN302

CN303

CN702

CN604

CN902

CN302

CN303

CN702

CN604

CN902

CN302

CN303

CN702

CN604

CN902

CN302

CN303

CN702

CN604

CN902

CN302

CN303

CN702

A-a

A-a A-b

A

B

C

D

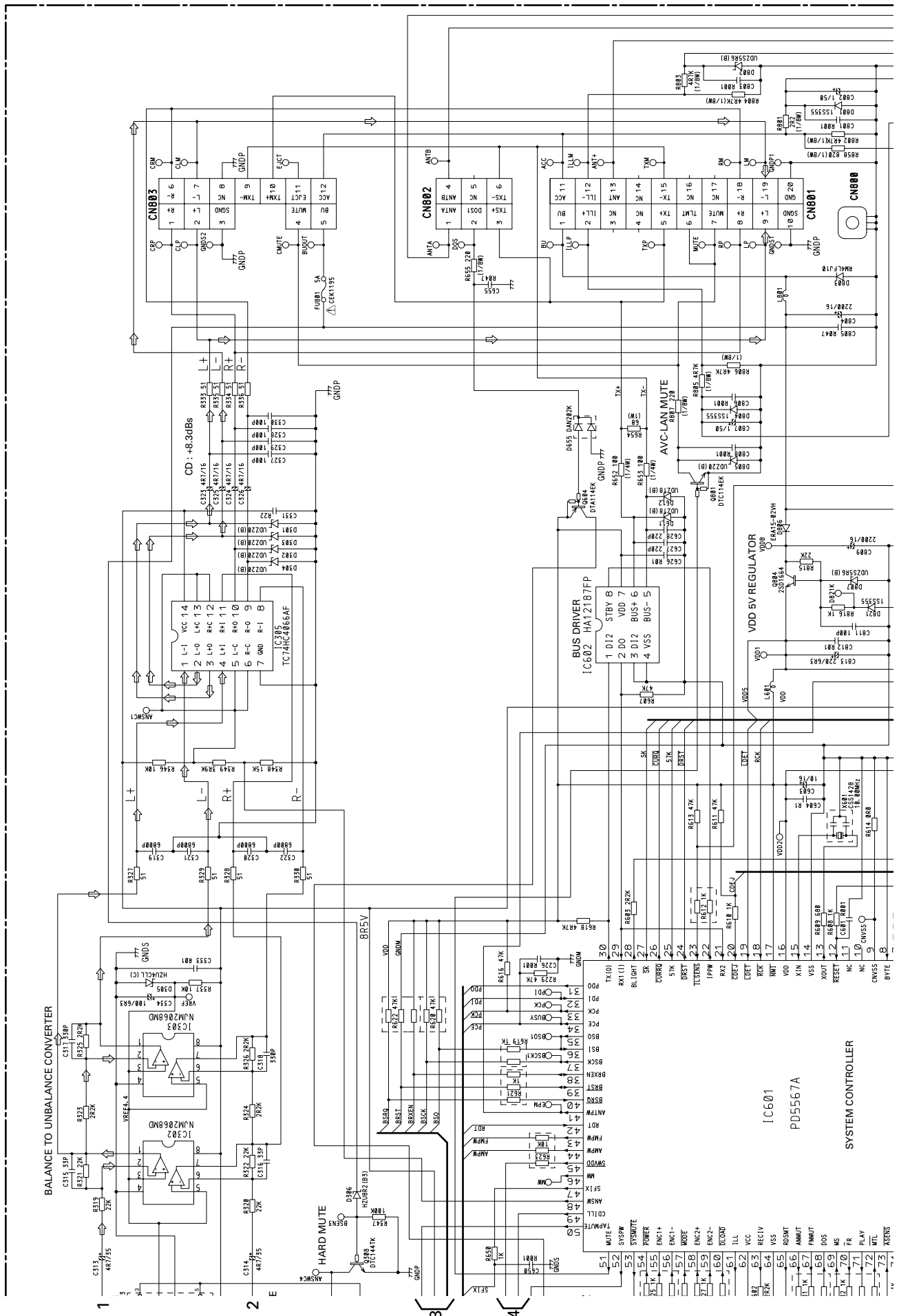

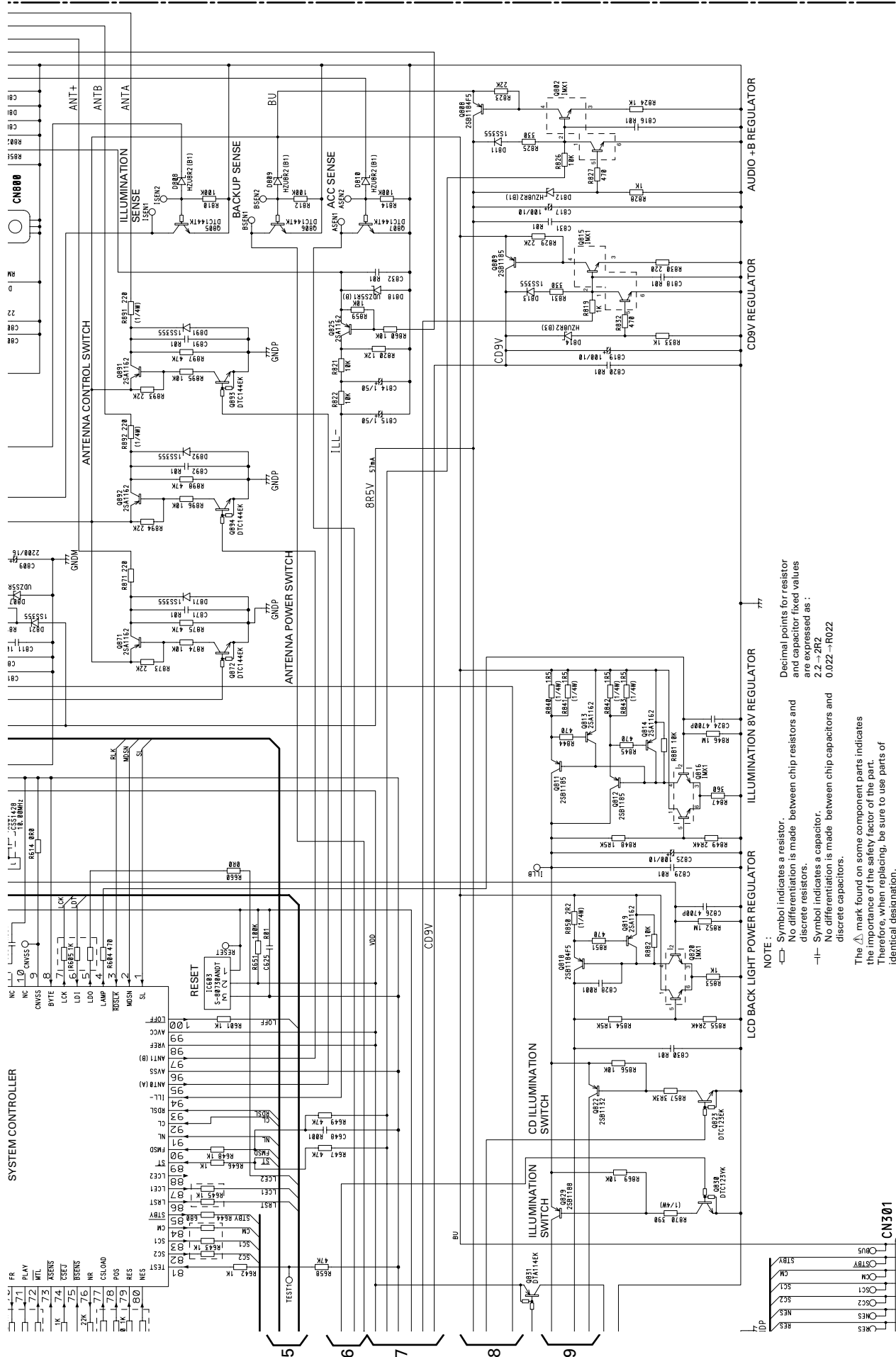

NOTE:

- Symbol indicates a resistor.
- No differentiation is made between chip resistors and discrete resistors.
- Symbol indicates a capacitor.
- No differentiation is made between chip capacitors and discrete capacitors.

Decimal points for resistor and capacitor fixed values are expressed as:
 2.2 → 2R2
 0.022 → R022

The Δ mark found on some component parts indicates the importance of the safety factor of the part. Therefore, when replacing, be sure to use parts of identical designation.

A-a A-b

A

B

C

D

A-b

3.3 FM/AM TUNER UNIT

B FM/AM TUNER UNIT

A

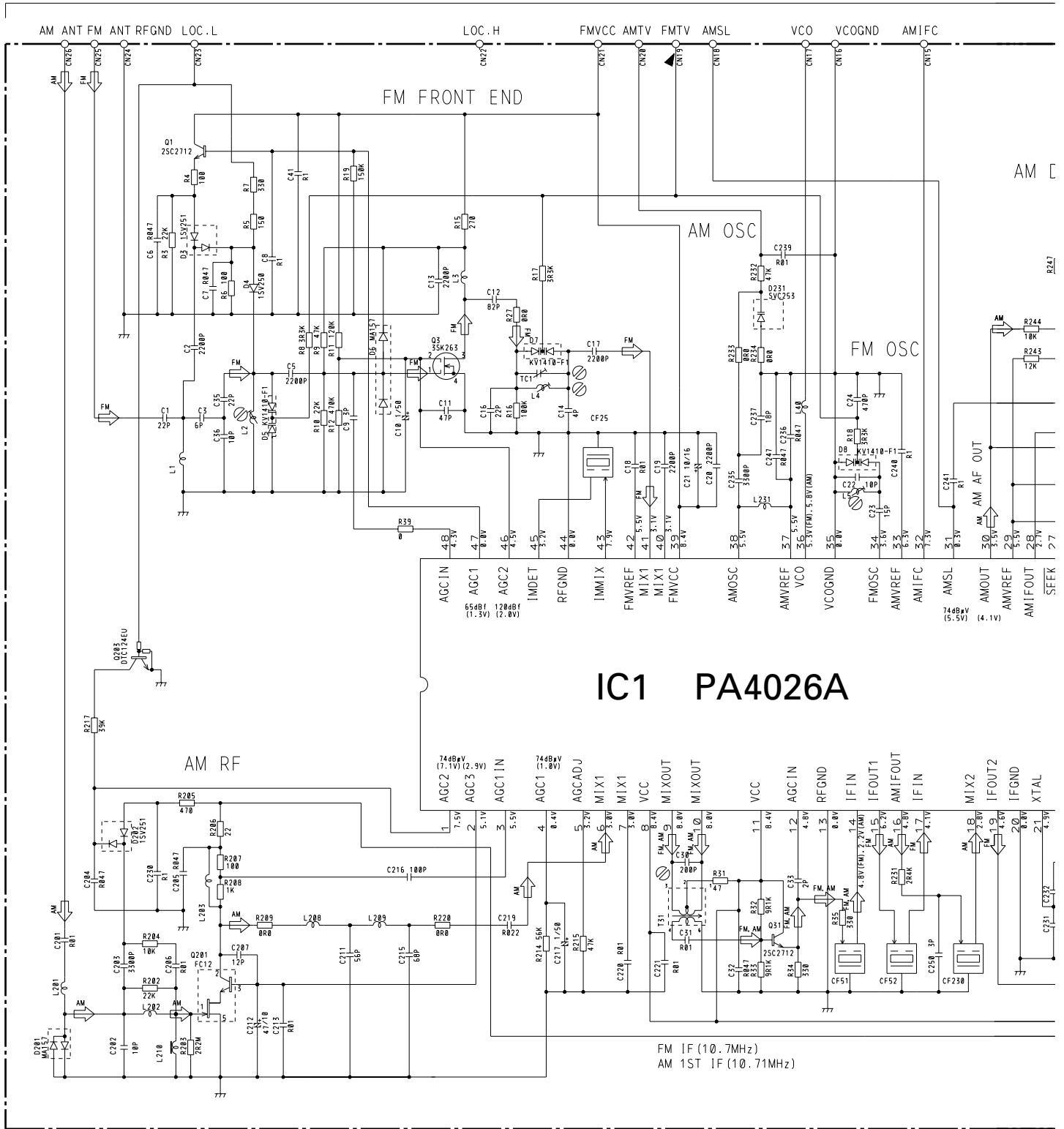

1 2 3 4

FX-MG8156ZT, MG8156ZT-91, MG8317ZT, MG8317ZT-91

3.4 KEYBOARD UNIT

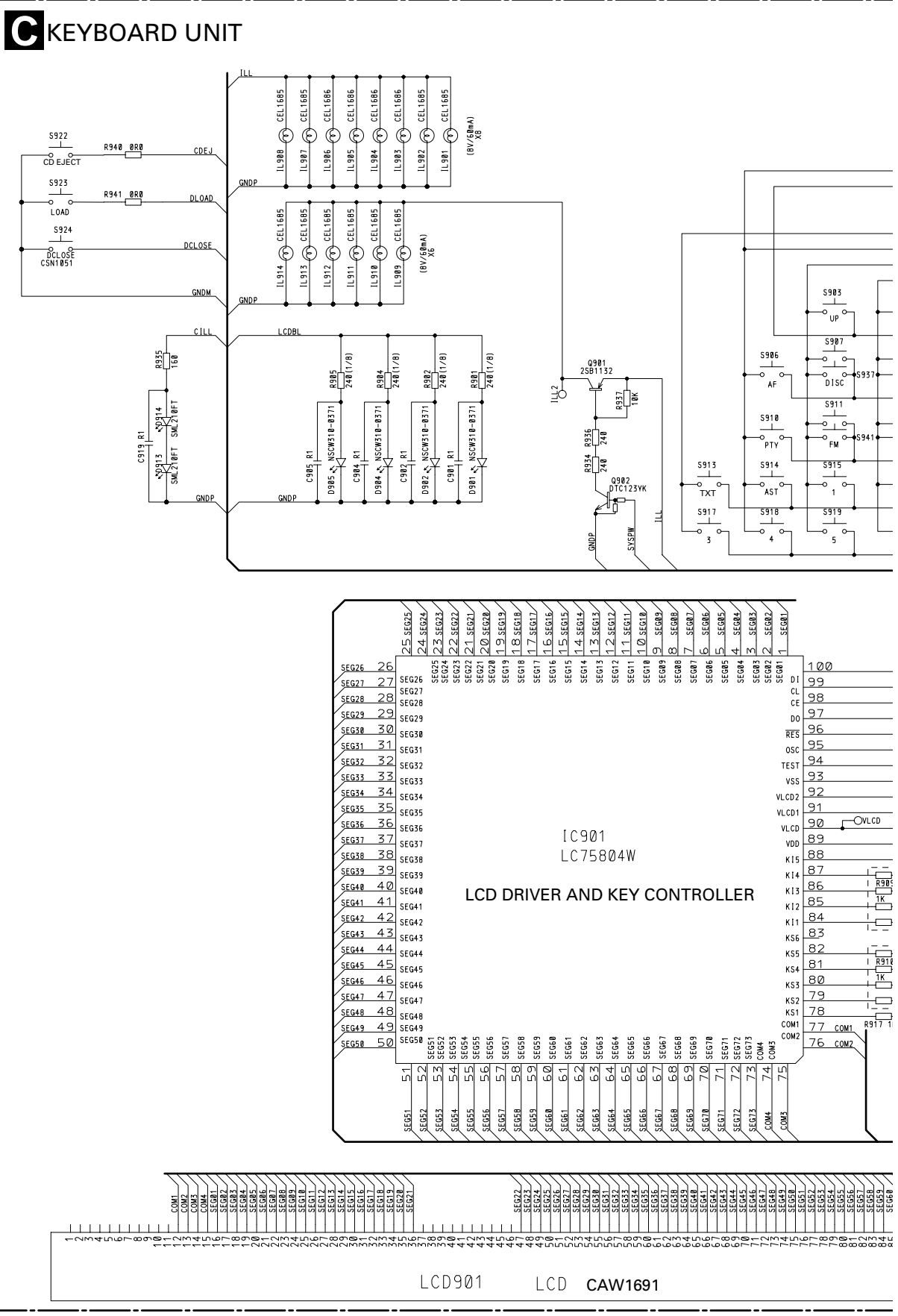

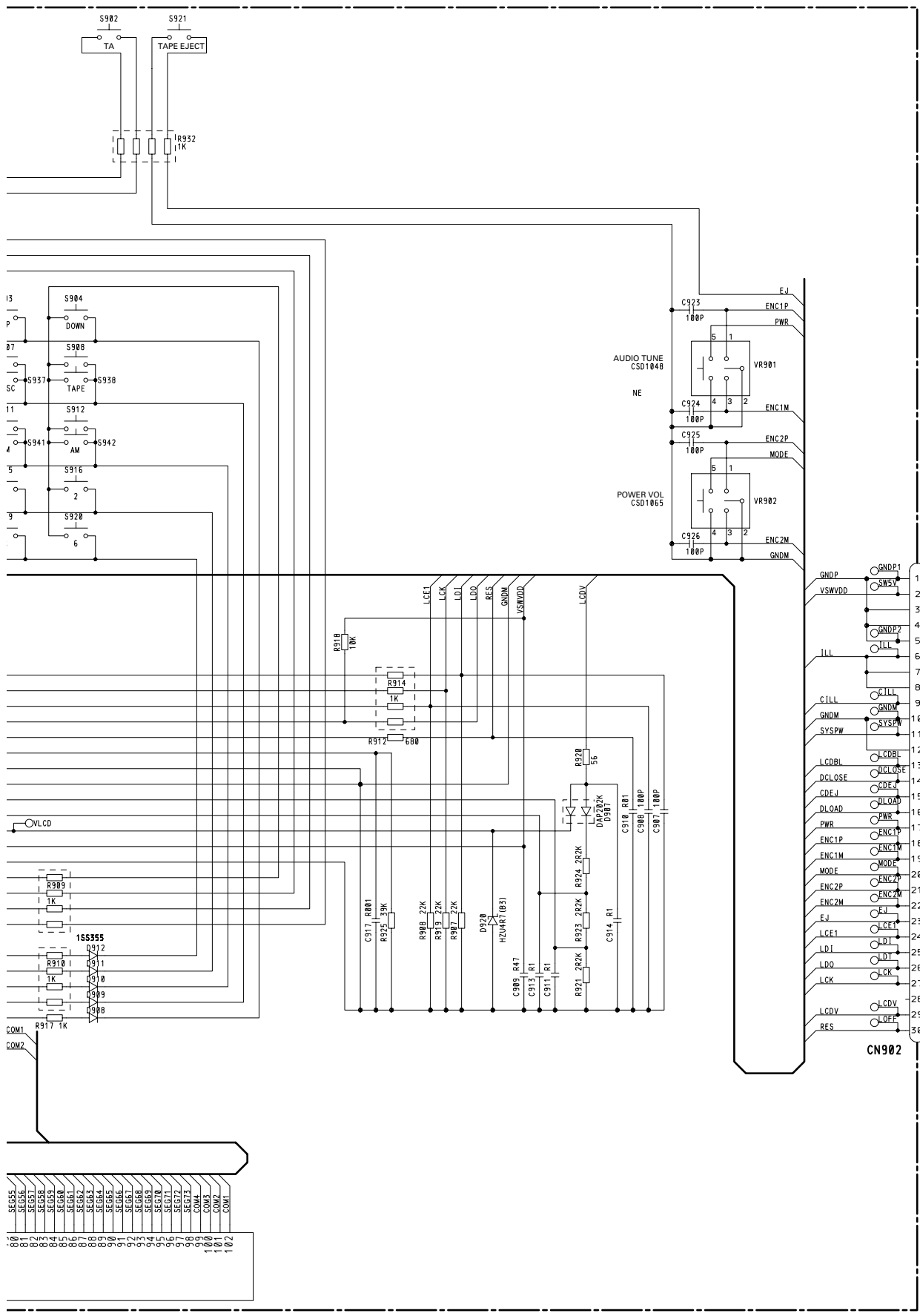

- SE655
- SE656
- SE657
- SE658
- SE659
- SE660
- SE661
- SE662
- SE663
- SE664
- SE665
- SE666
- SE667
- SE668
- SE669
- SE670
- SE671
- SE672
- SE673
- SE674
- SE675
- SE676
- SE677
- SE678
- SE679
- SE680
- SE681
- SE682
- SE683
- SE684
- SE685
- SE686
- SE687
- SE688
- SE689
- SE690
- SE691
- SE692
- SE693
- SE694
- SE695
- SE696
- SE697
- SE698
- SE699
- SE700
- SE701
- SE702
- SE703
- SE704
- SE705
- SE706
- SE707
- SE708
- SE709
- SE710
- SE711
- SE712
- SE713
- SE714
- SE715
- SE716
- SE717
- SE718
- SE719
- SE720
- SE721
- SE722
- SE723
- SE724
- SE725
- SE726
- SE727
- SE728
- SE729
- SE730
- SE731
- SE732
- SE733
- SE734
- SE735
- SE736
- SE737
- SE738
- SE739
- SE740
- SE741
- SE742
- SE743
- SE744
- SE745
- SE746
- SE747
- SE748
- SE749
- SE750
- SE751
- SE752
- SE753
- SE754
- SE755
- SE756
- SE757
- SE758
- SE759
- SE760
- SE761
- SE762
- SE763
- SE764
- SE765
- SE766
- SE767
- SE768
- SE769
- SE770
- SE771
- SE772
- SE773
- SE774
- SE775
- SE776
- SE777
- SE778
- SE779
- SE780
- SE781
- SE782
- SE783
- SE784
- SE785
- SE786
- SE787
- SE788
- SE789
- SE790
- SE791
- SE792
- SE793
- SE794
- SE795
- SE796
- SE797
- SE798
- SE799
- SE800

A CN804

CN902



3.5 CD CORE UNIT(SERVO UNIT)

E CD CORE UNIT(SERVO UNIT)

A

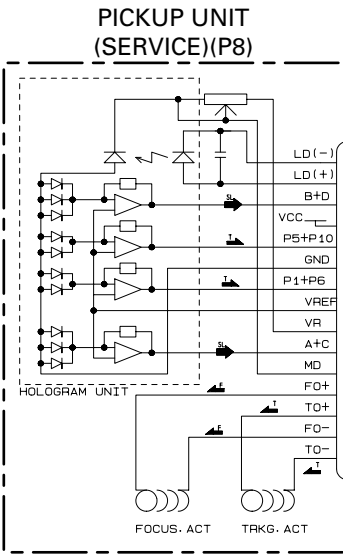

SIGNAL LINE
 FOCUS SERVO LINE
 TRACKING SERVO LINE
 CARRIAGE SERVO LINE
 SPINDLE SERVO LINE

B

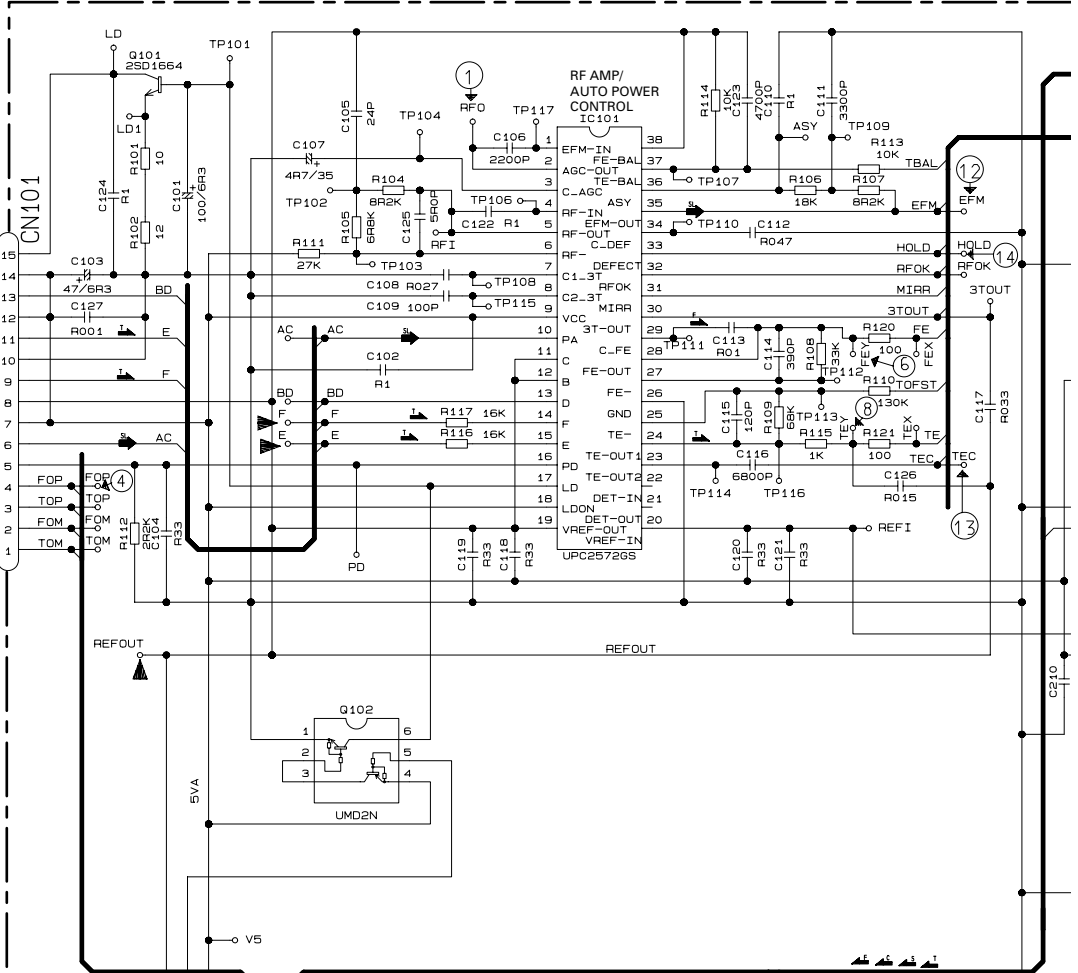

C

D MOTOR PCB(B)

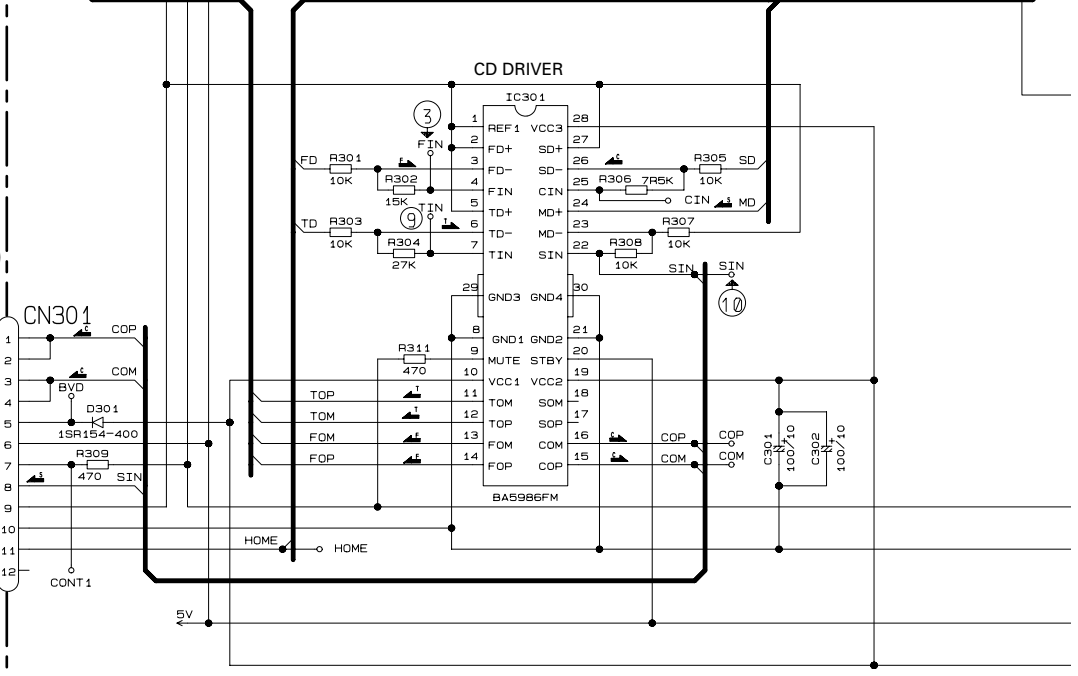
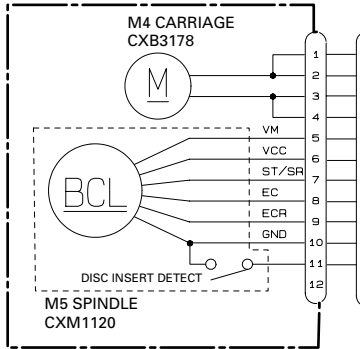

D

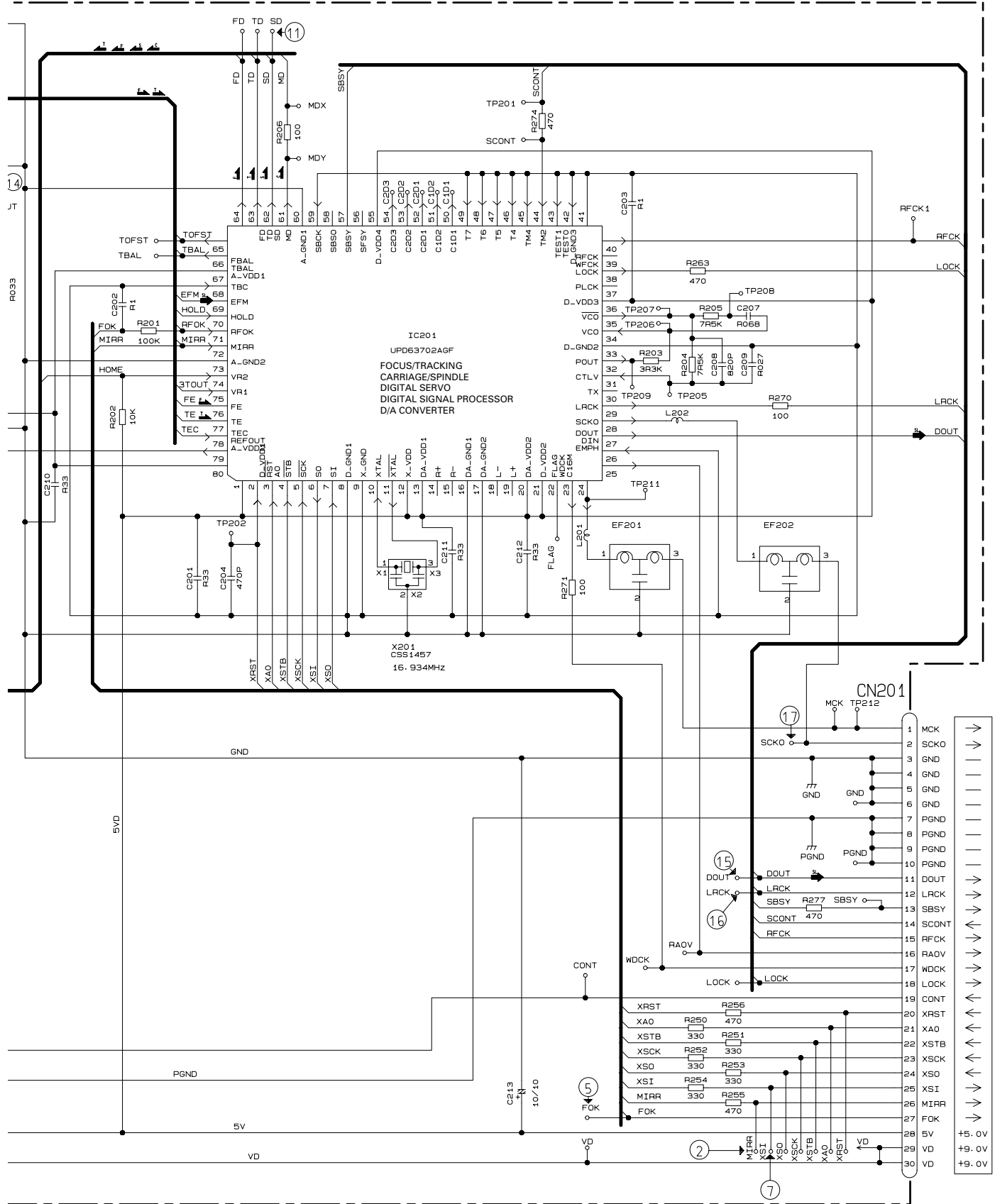

A
 B
 C
 D
 F

G CD CORE UNIT (STS UNIT)

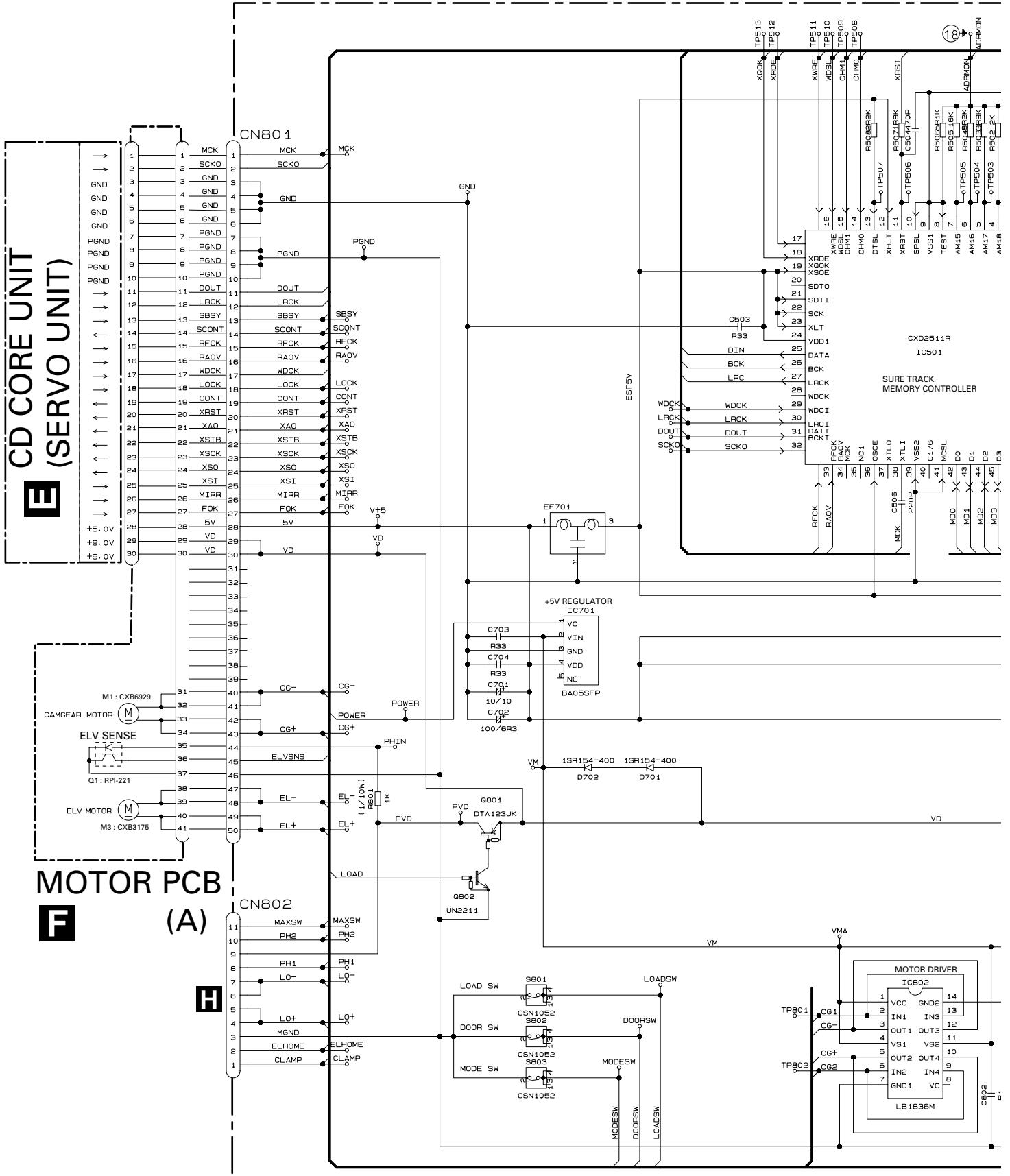

F MOTOR PCB (A)

H

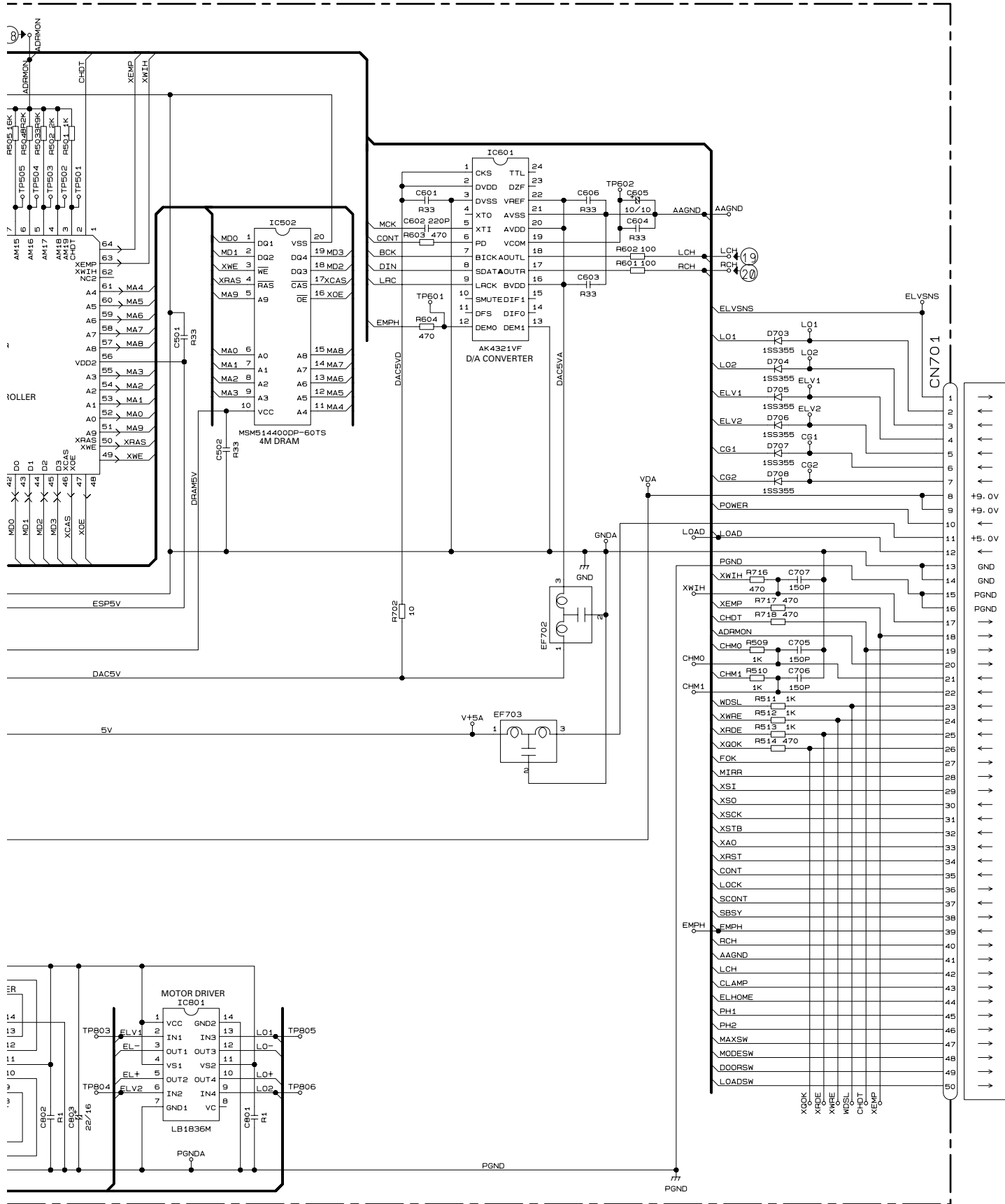

A
 B
 C
 D

Q CN701



Note: 1. The encircled numbers denote measuring pointes in the circuit diagram.
 2. Reference voltage
 REFOUT: 2.5V

● **Waveforms**

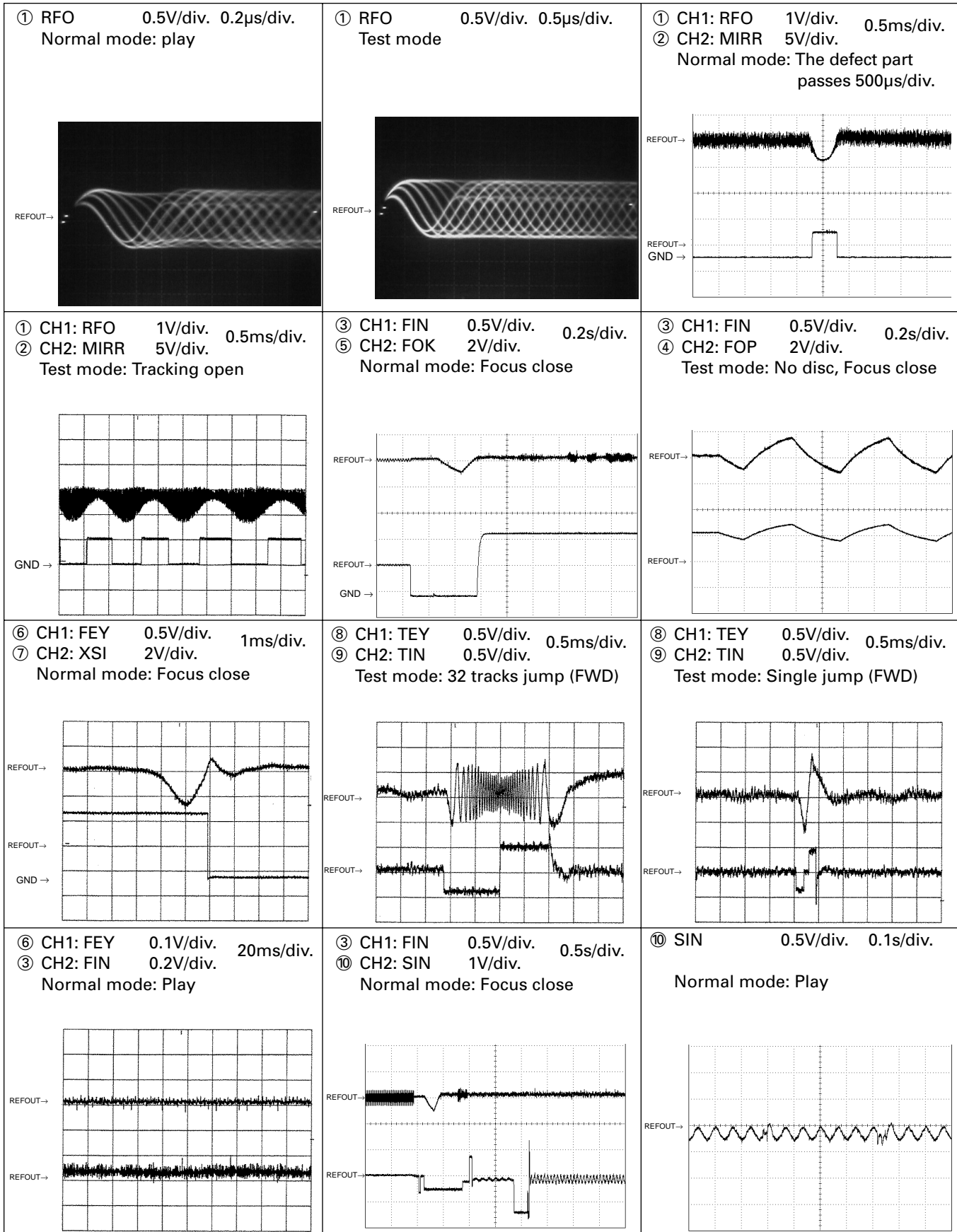

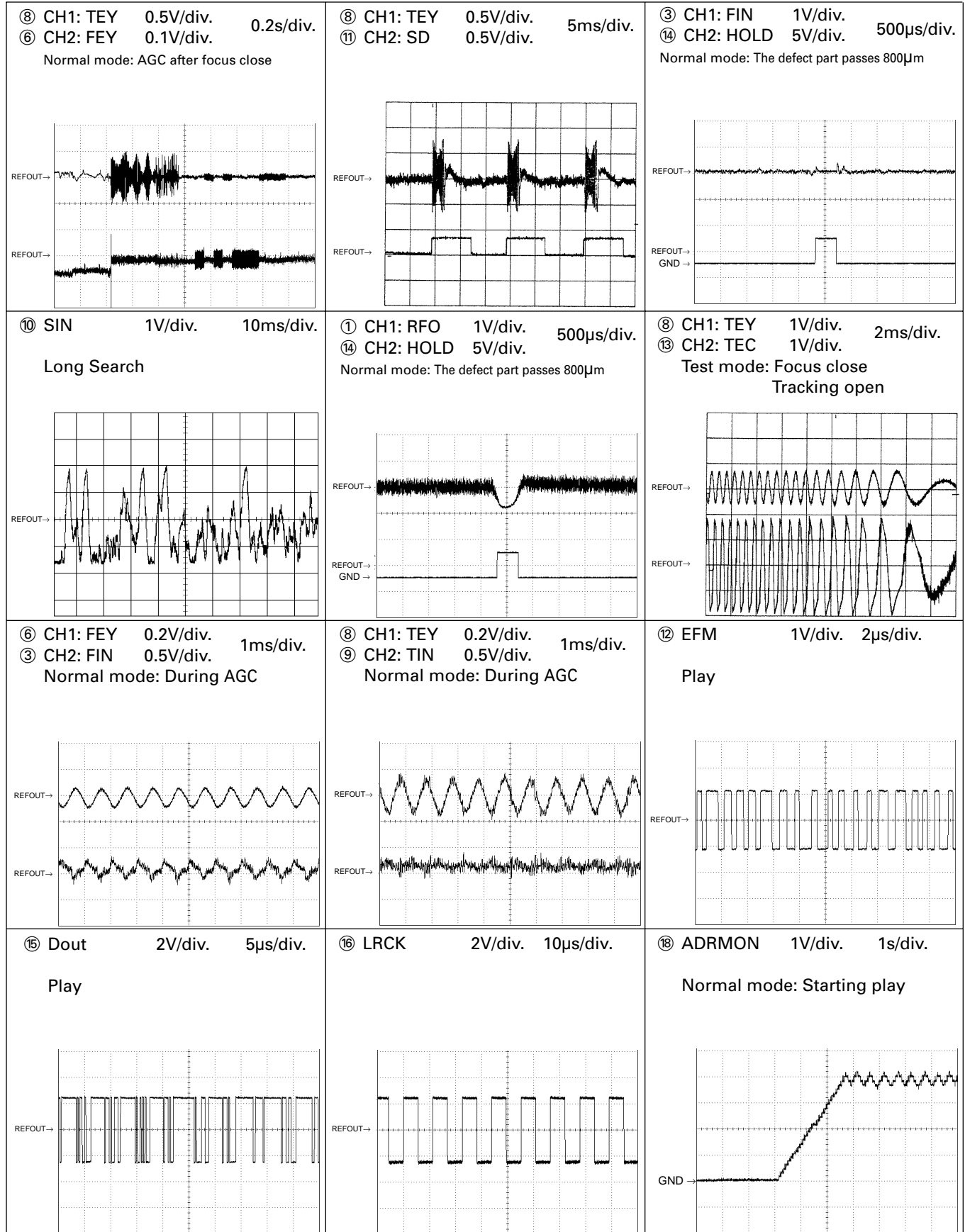

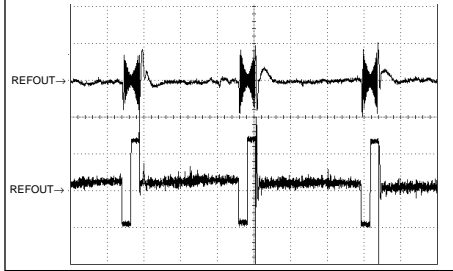
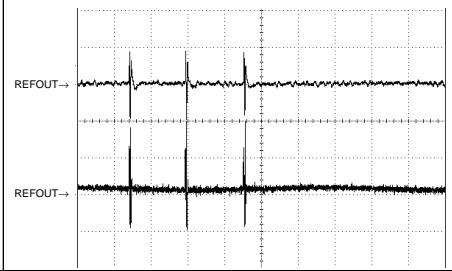
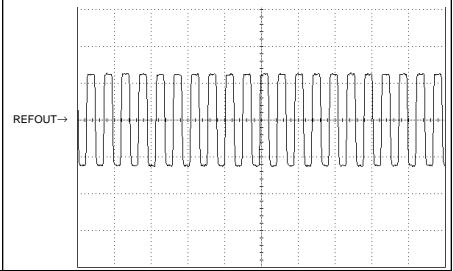
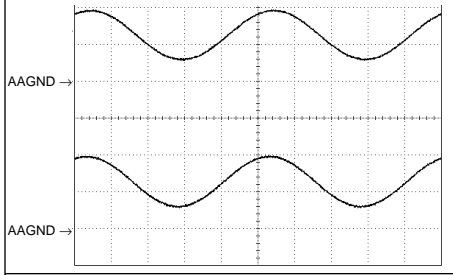
<p>⑧ CH1: TEY 0.5V/div. 5ms/div. ⑨ CH2: TIN 0.5V/div. Test mode: 100 tracks jump(FWD)</p> 	<p>⑧ CH1: TEY 0.5V/div. 10ms/div. ⑨ CH2: TIN 0.5V/div. Normal mode: Play</p> 	<p>⑰ SCKO 2V/div. 500ns/div. Play</p> 
<p>⑳ CH1: RCH 2V/div. 200μs/div. ⑲ CH2: LCH 2V/div. Normal mode: PLAY (0dB, 1kHz)</p> 		

3.7 PCB UNIT(A,B,C,D,E), LOAD MOTOR PCB

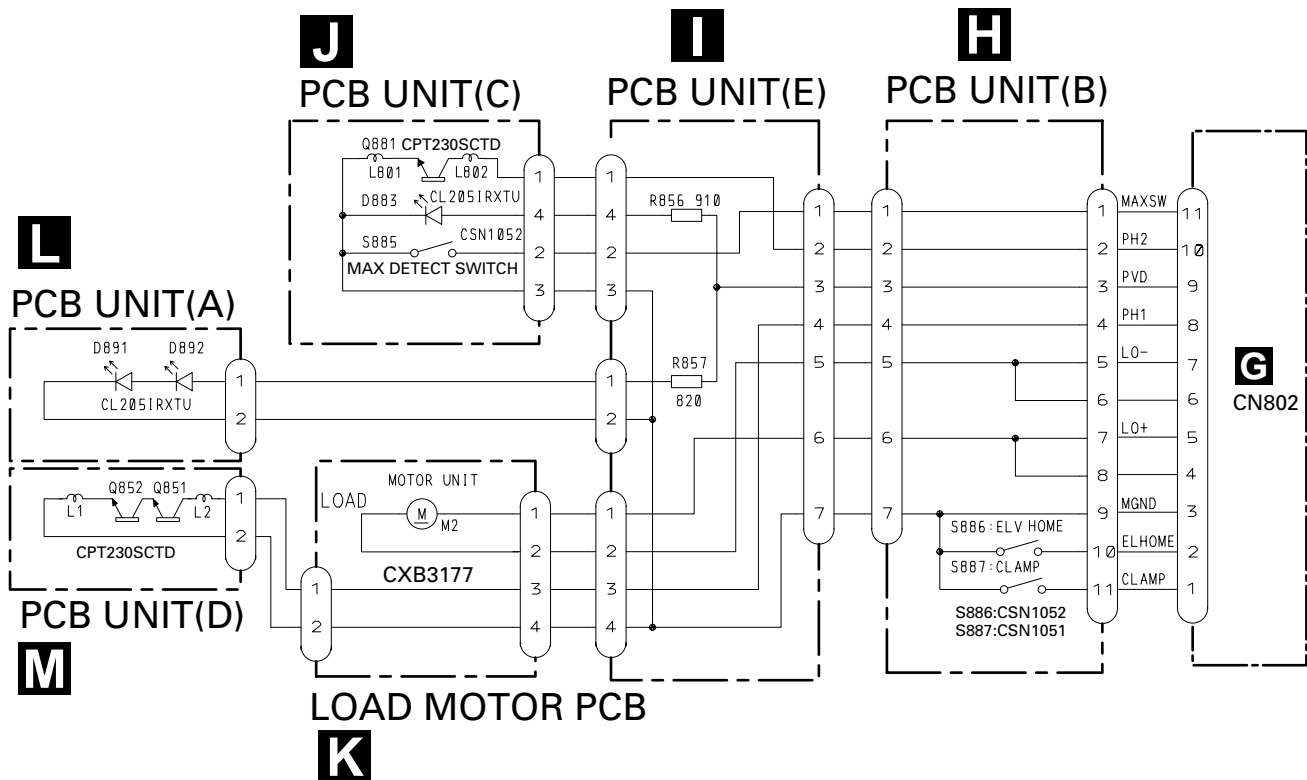

3.8 CASSETTE MECHANISM MODULE

N DECK UNIT

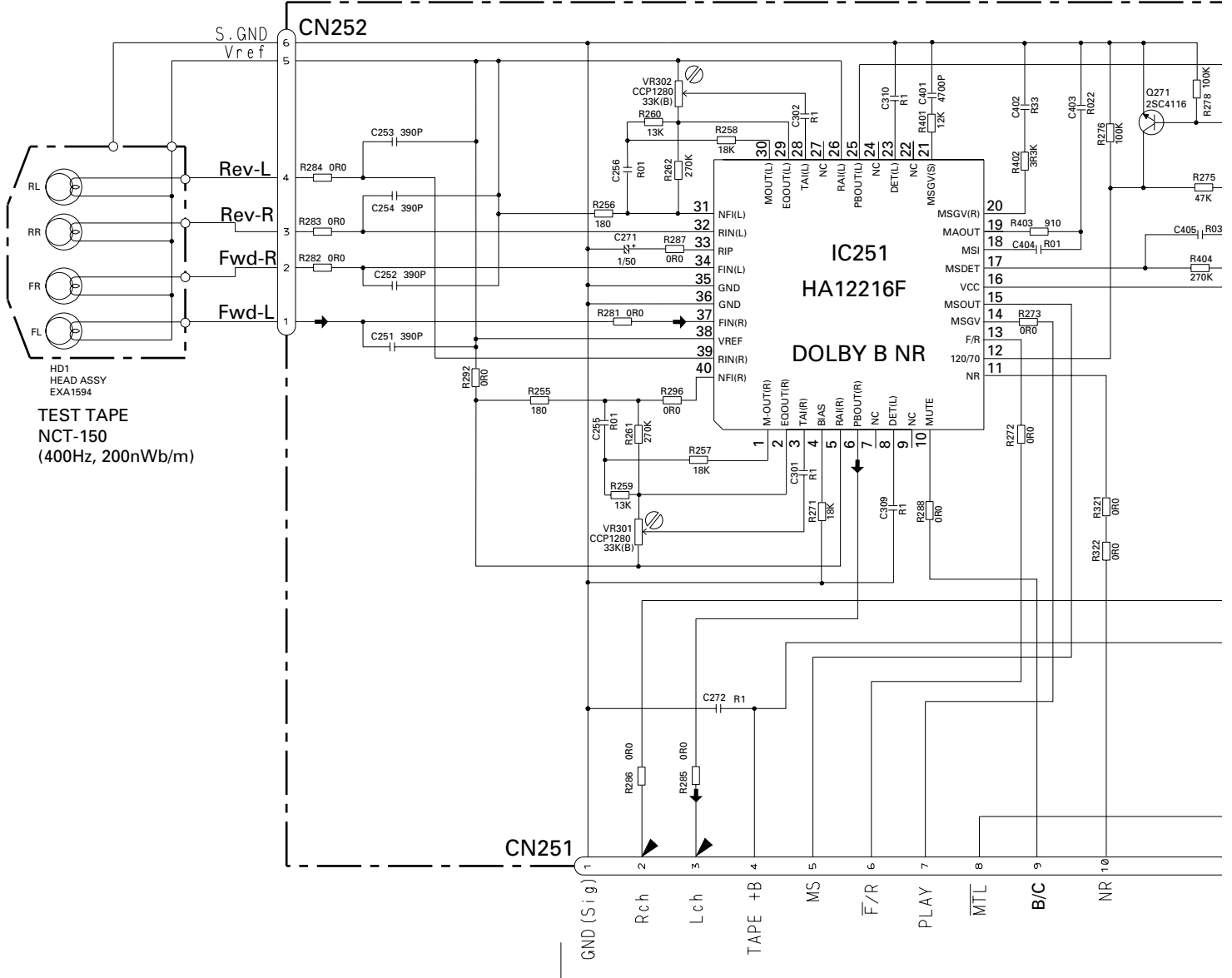

-8.24dBs(300mV)±1dB

A CN301



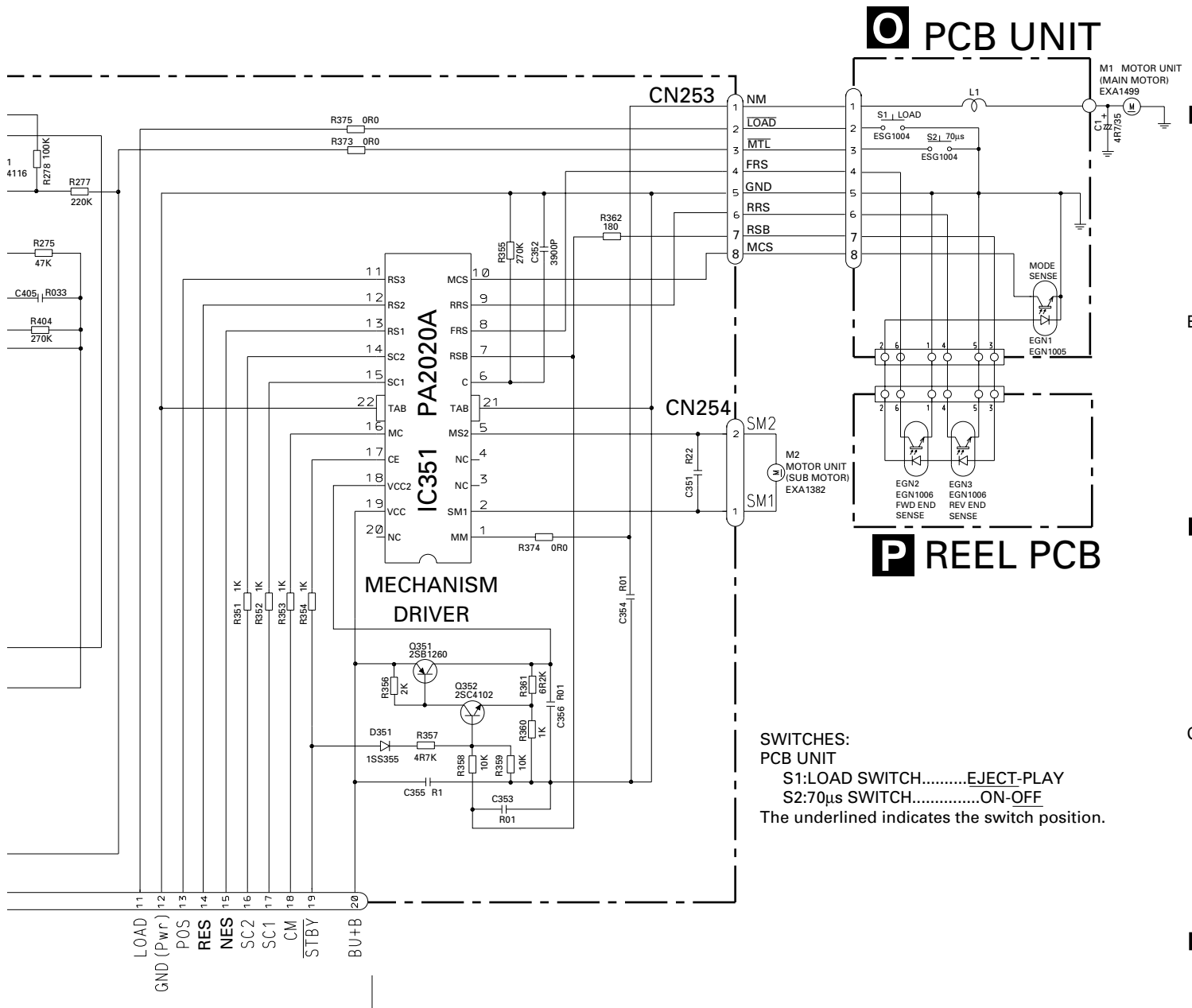

3.9 CONTROL UNIT

CONTROL UNIT

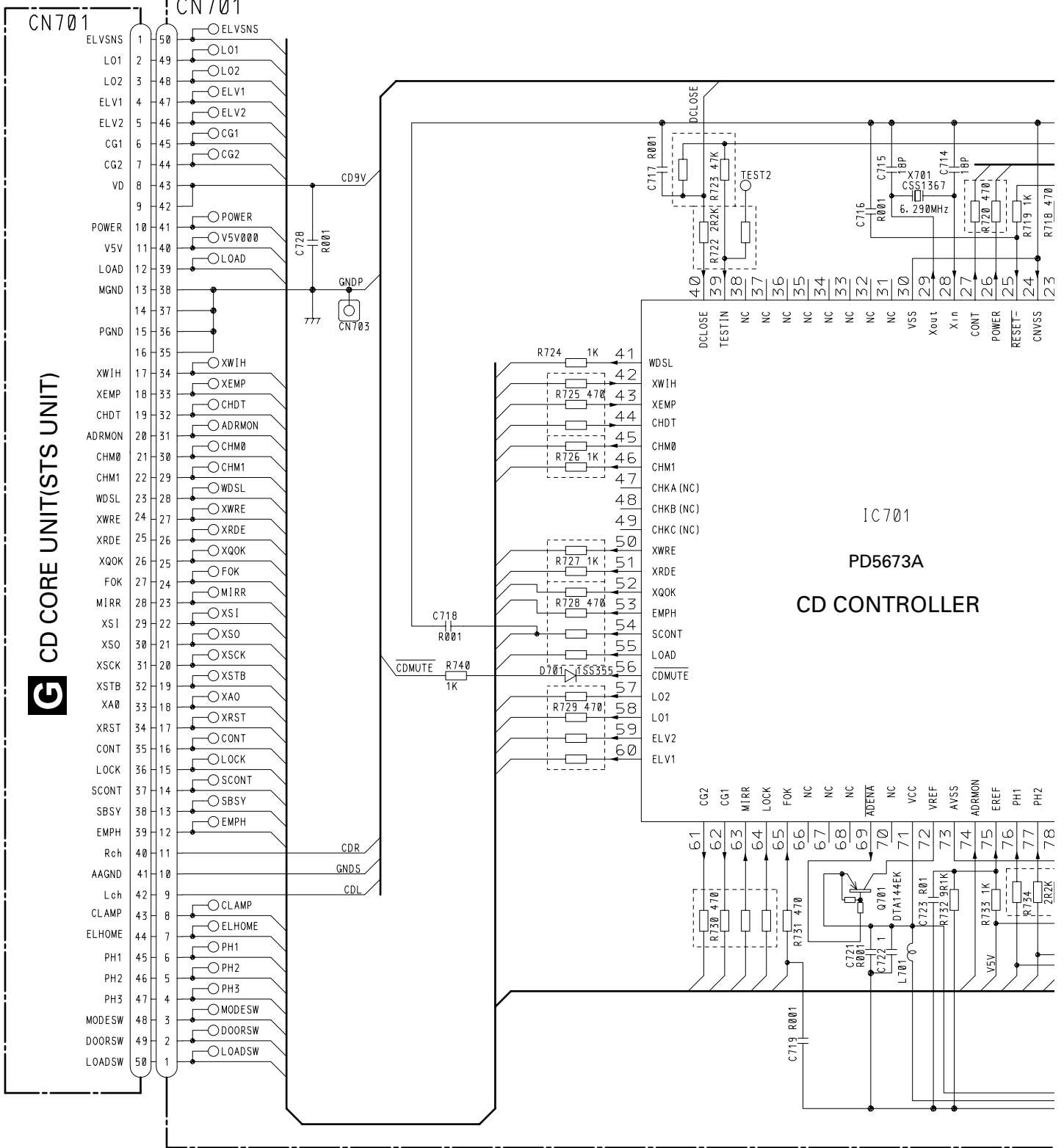

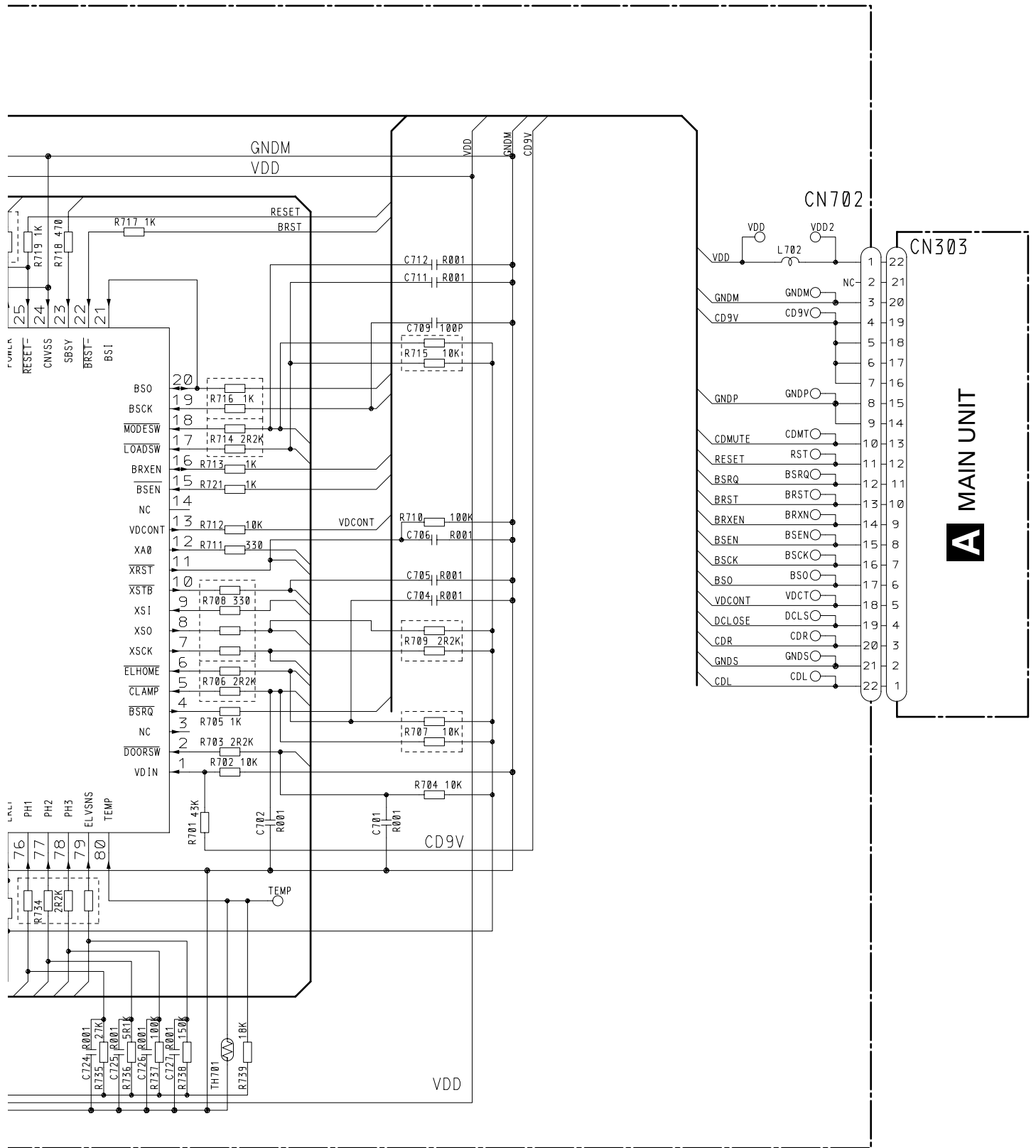

4. PCB CONNECTION DIAGRAM

4.1 MAIN UNIT

NOTE FOR PCB DIAGRAMS

1. The parts mounted on this PCB include all necessary parts for several destination.
 For further information for respective destinations, be sure to check with the schematic diagram.

2. Viewpoint of PCB diagrams

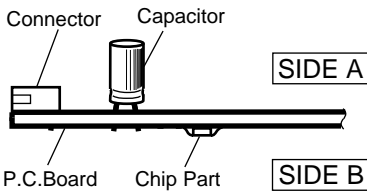

Q810	Q809	IC, Q	ADJ
Q817	Q815		
Q811	Q811		
Q821	Q821		
Q891	Q892		
Q816	Q805		
Q806	Q806		
Q812	Q894		
Q893	Q893		
Q807	Q807		
Q505	IC501		
Q819	Q819		
Q820	Q825	Q506	
Q804	Q501	Q504	
		Q305	
		Q507	
Q801	IC451		
Q308	IC301		
	Q818		
IC305	Q303		
IC302	IC303		
	IC201		
Q808	Q802		
Q304	Q451		
	Q301		
	Q830		
	Q607		
Q307	Q601	Q861	
Q251	Q862	Q863	
Q605	Q823	Q405	
IC602	Q831	IC251	
	Q829	Q864	
		Q603	
		Q551	
		Q403	
Q402	IC553		
	IC601		
Q822	Q401		
IC604	IC252		
	Q406		
	IC603		
	Q503		
	Q606		

A MAIN UNIT

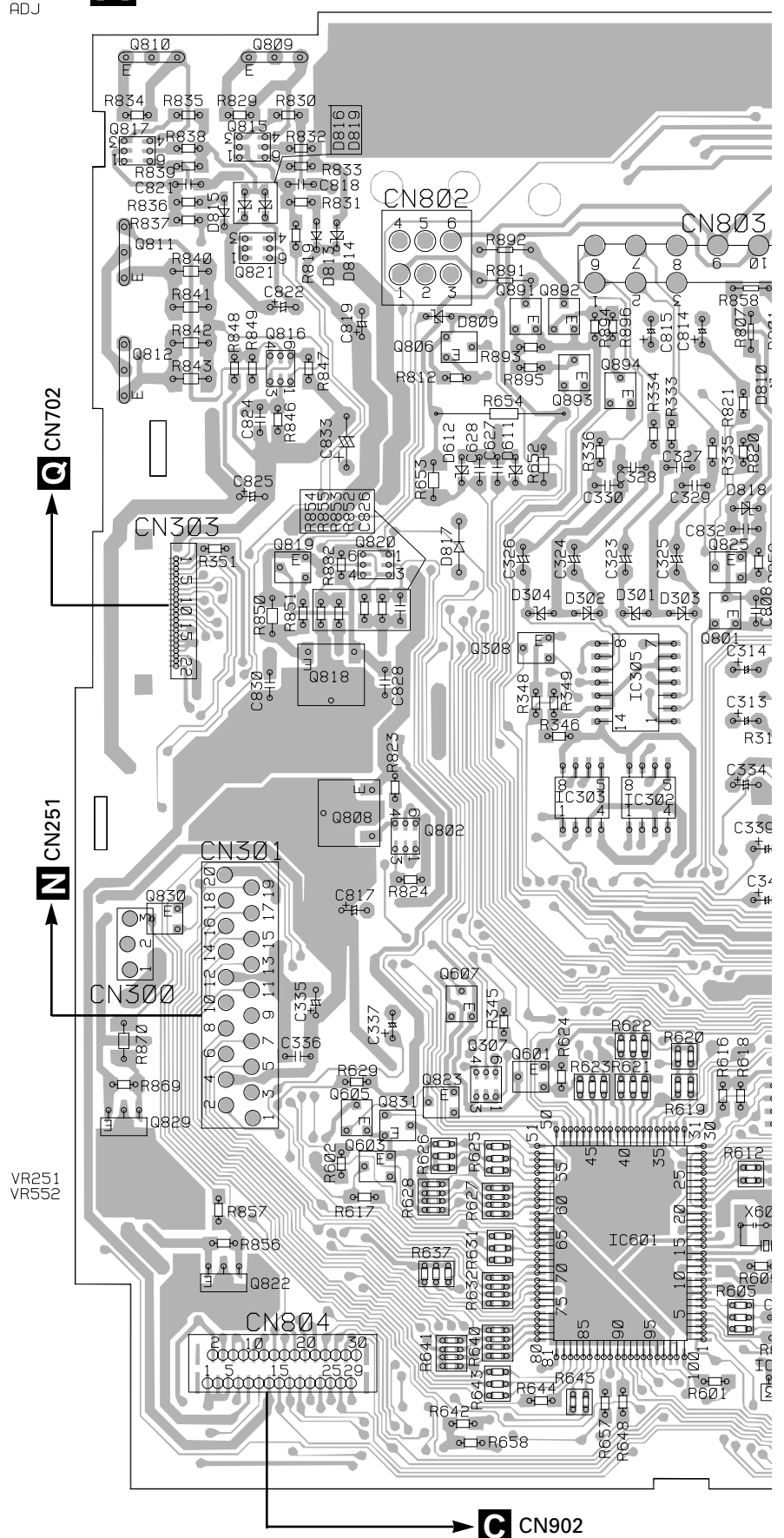

SIDE A

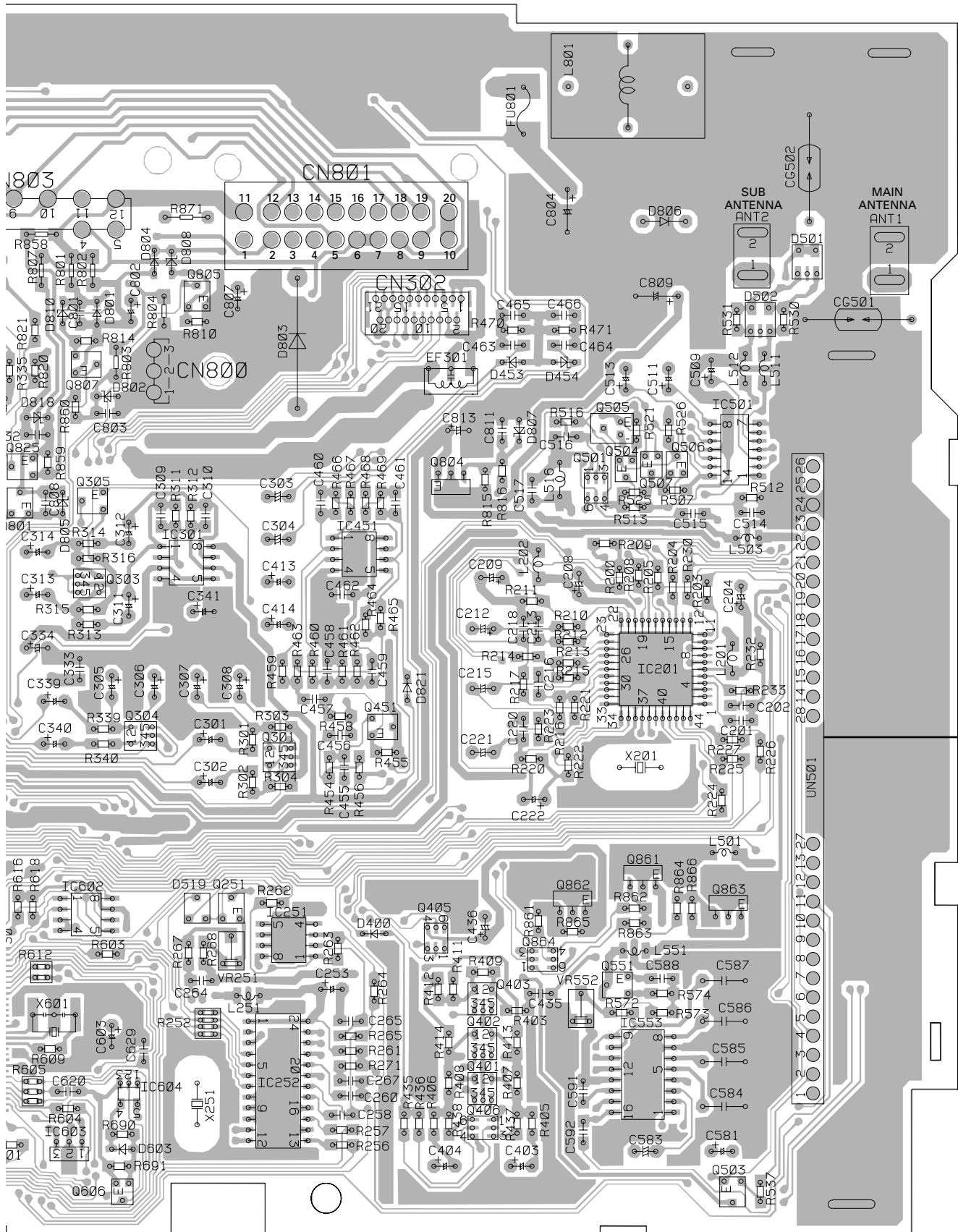

A

A MAIN UNIT

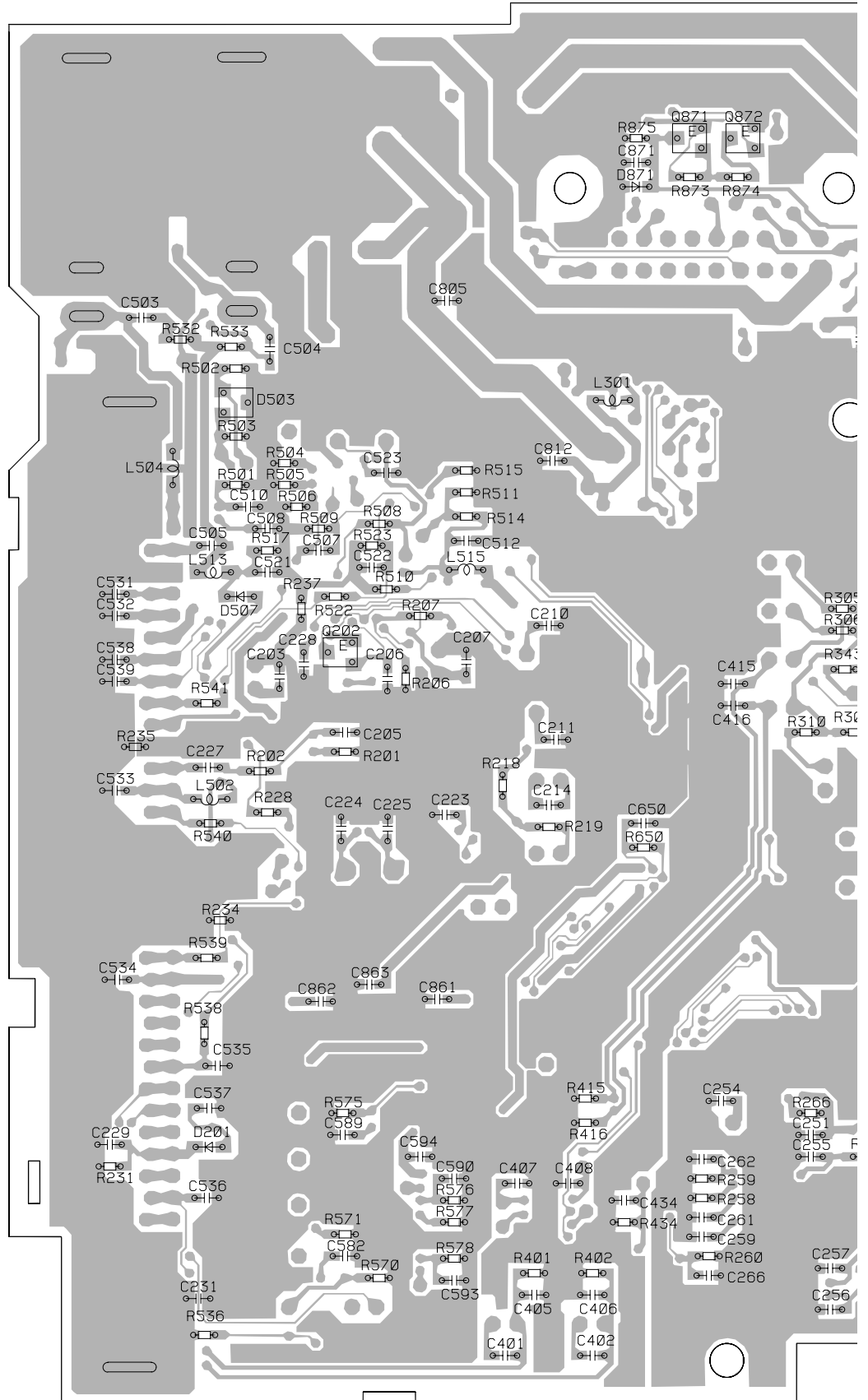

4.2 FM/AM TUNER UNIT

SIDE A

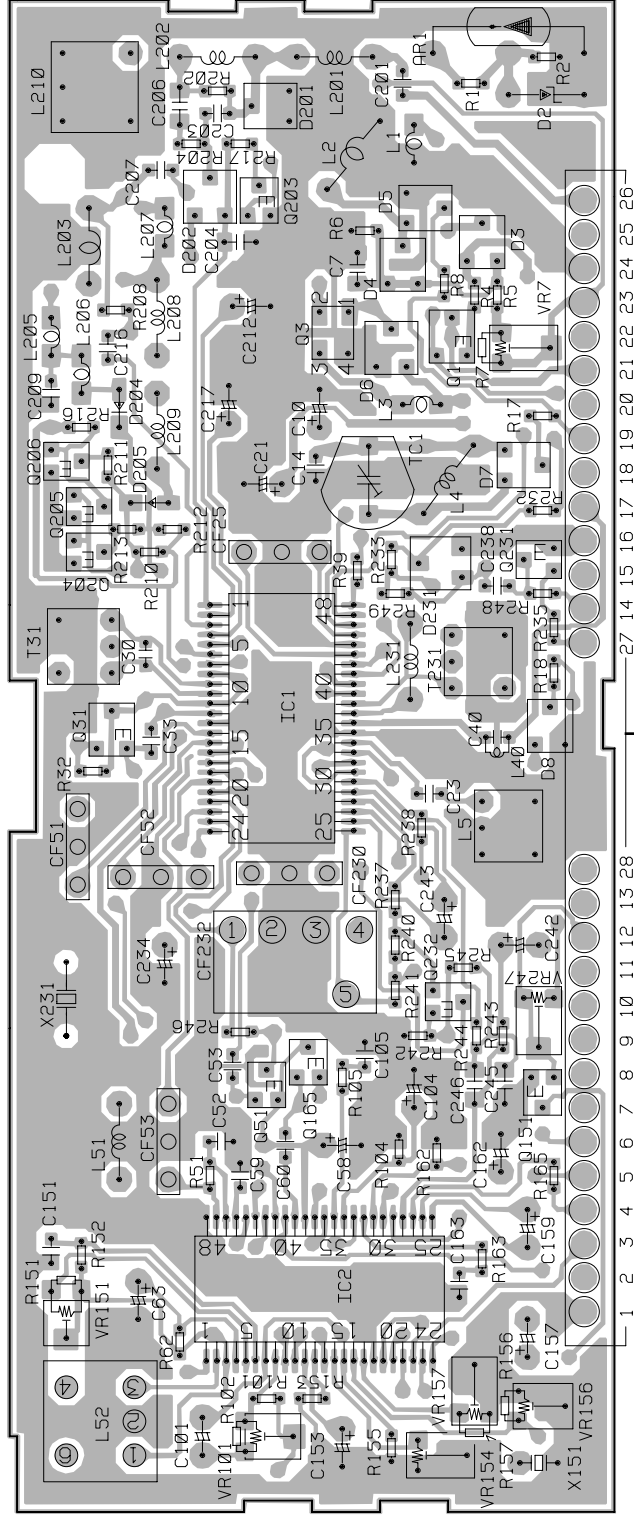

B FM/AM TUNER UNIT

IC, Q	ADJ
Q206	T31
Q205	L52
Q204	VR151
Q05	VR101
Q203	L2
Q165	TC1
Q232	VR154
Q1	L4
Q231	L5
Q151	T231
	VR156



SIDE B

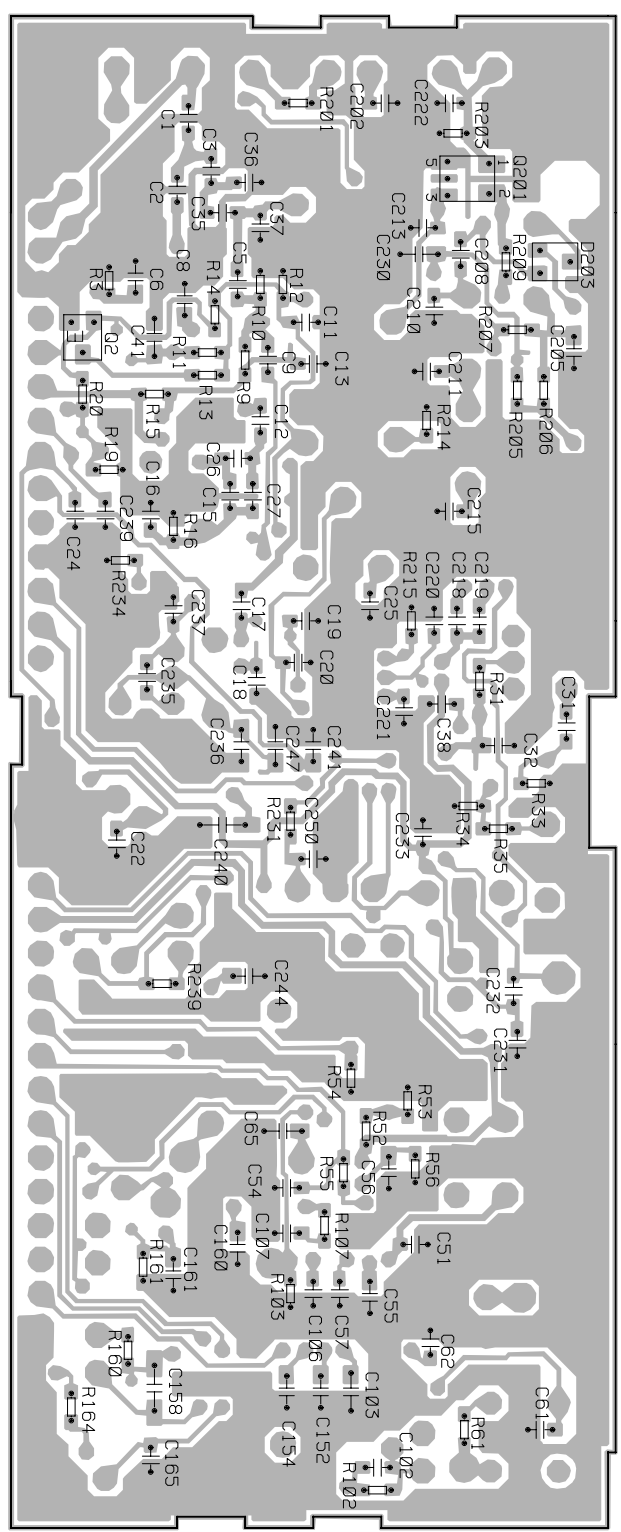

B FM/AM TUNER UNIT

0, CI
102D
2D

B

4.3 KEYBOARD UNIT

SIDE A

C KEYBOARD UNIT

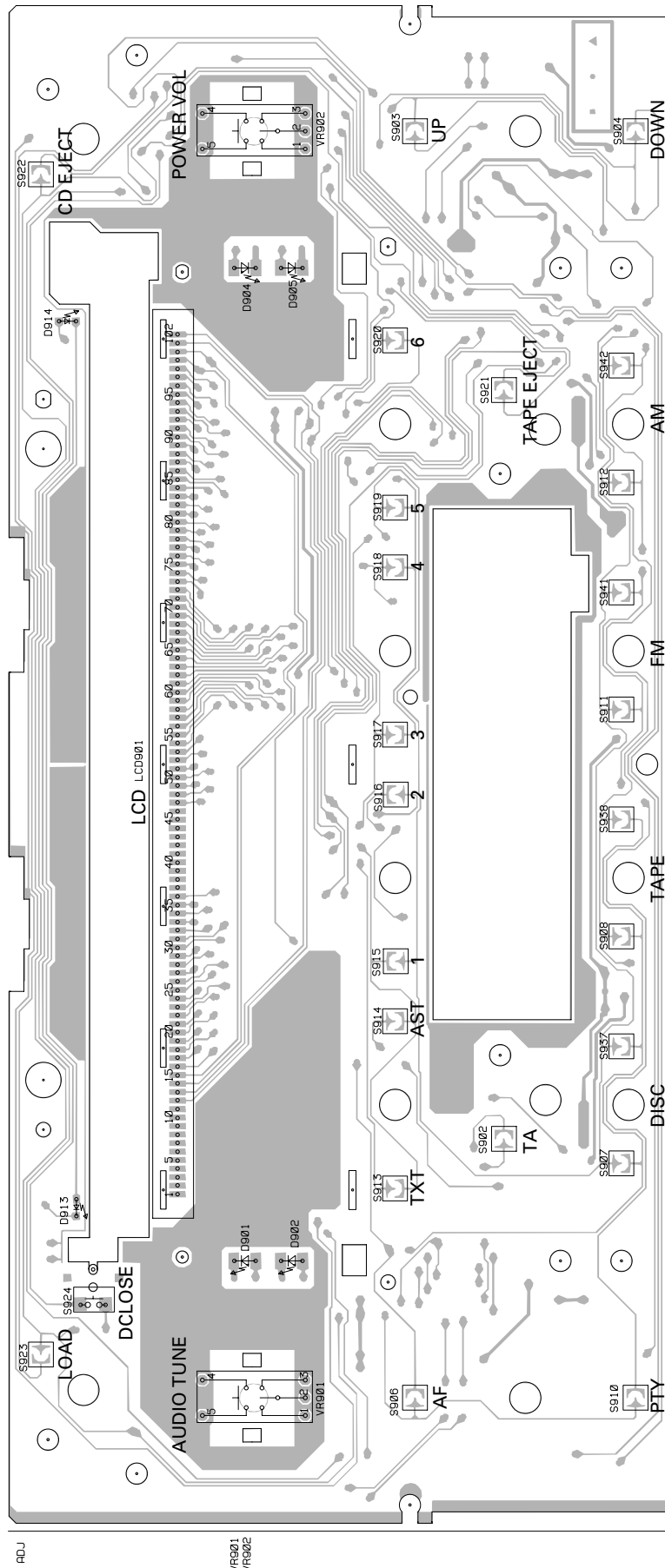

SIDE B

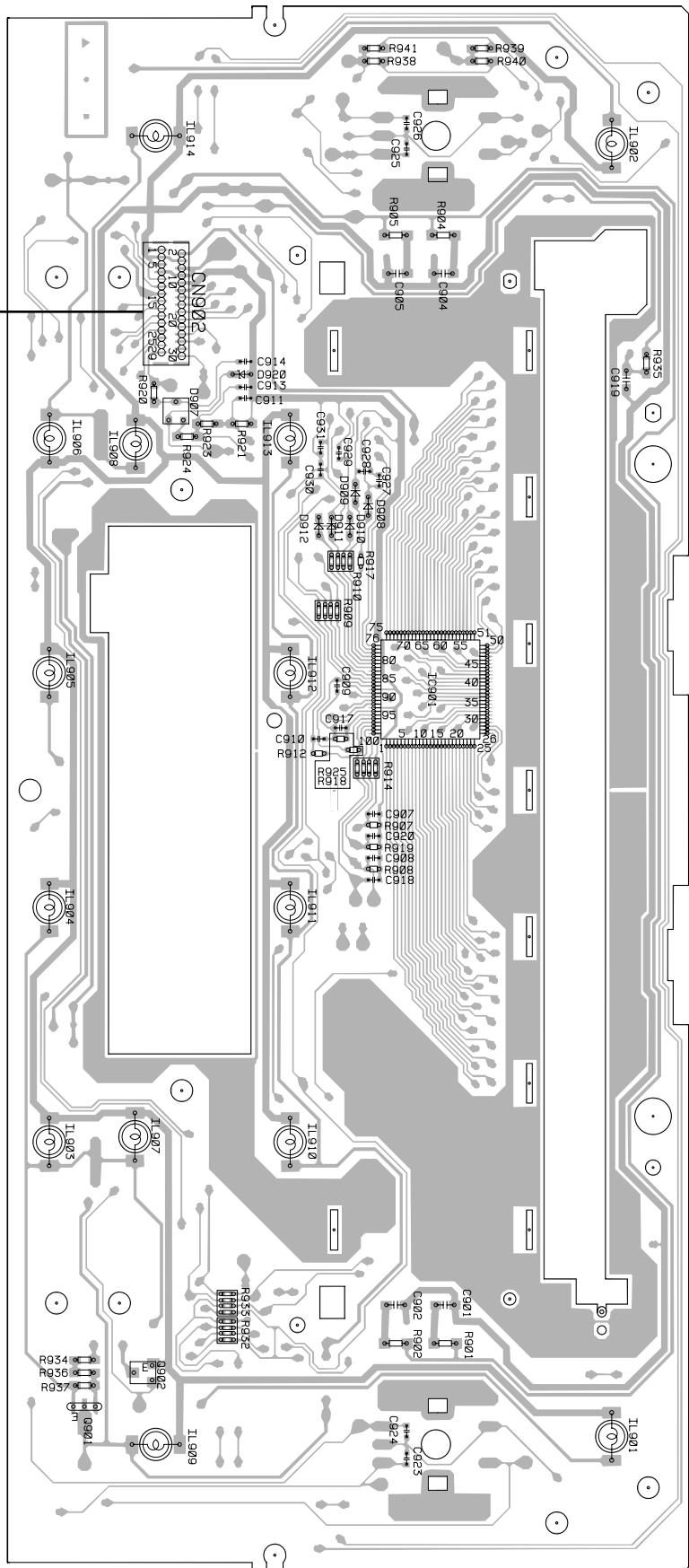

A CN804

KEYBOARD UNIT



A B C D



1 2 3 4
FX-MG8156ZT, MG8156ZT-91, MG8317ZT, MG8317ZT-91
4.5 CD CORE UNIT (STS UNIT)

G CD CORE UNIT (STS UNIT)

SIDE A

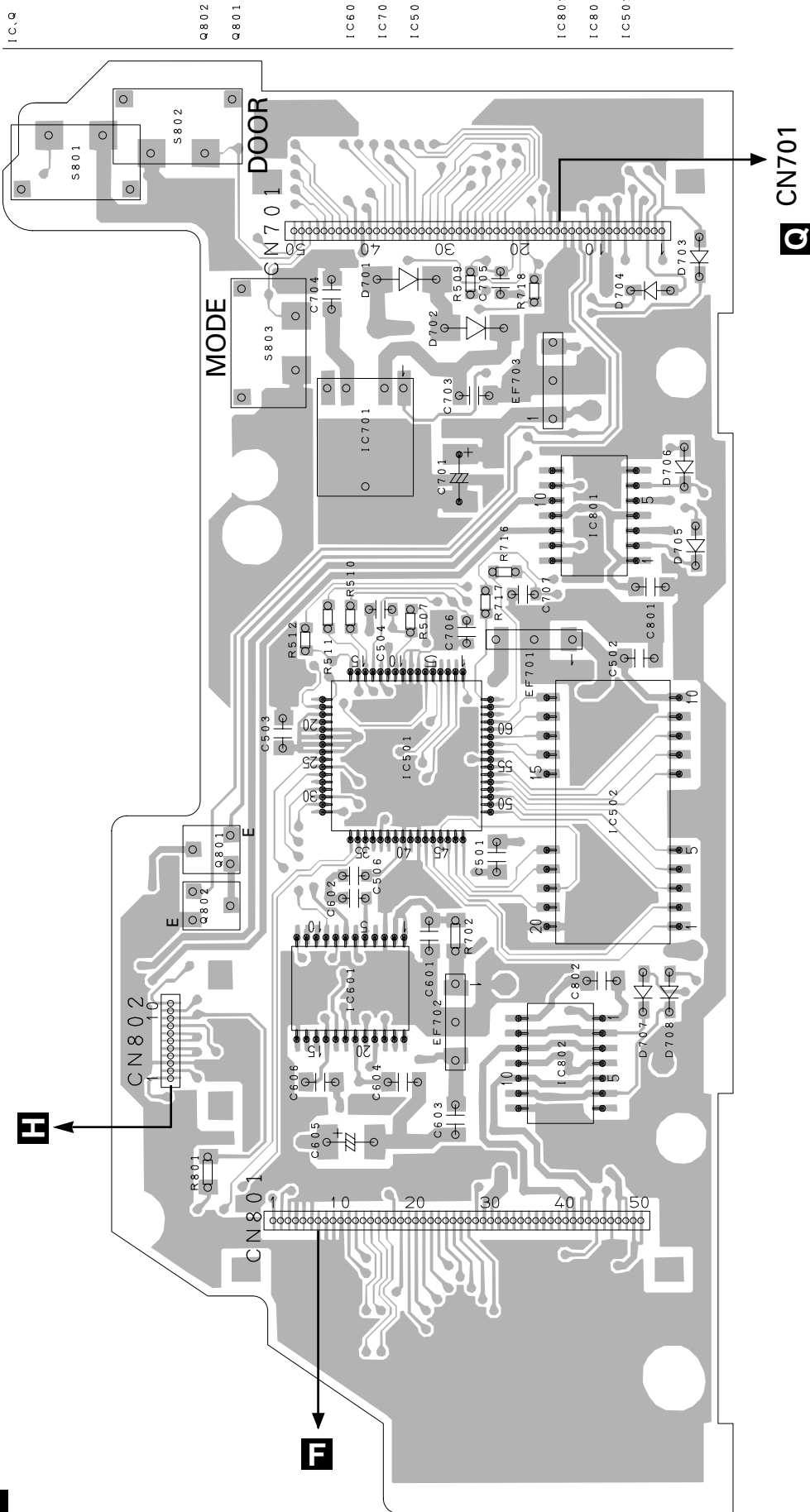

G CD CORE UNIT(STS UNIT)

SIDE B

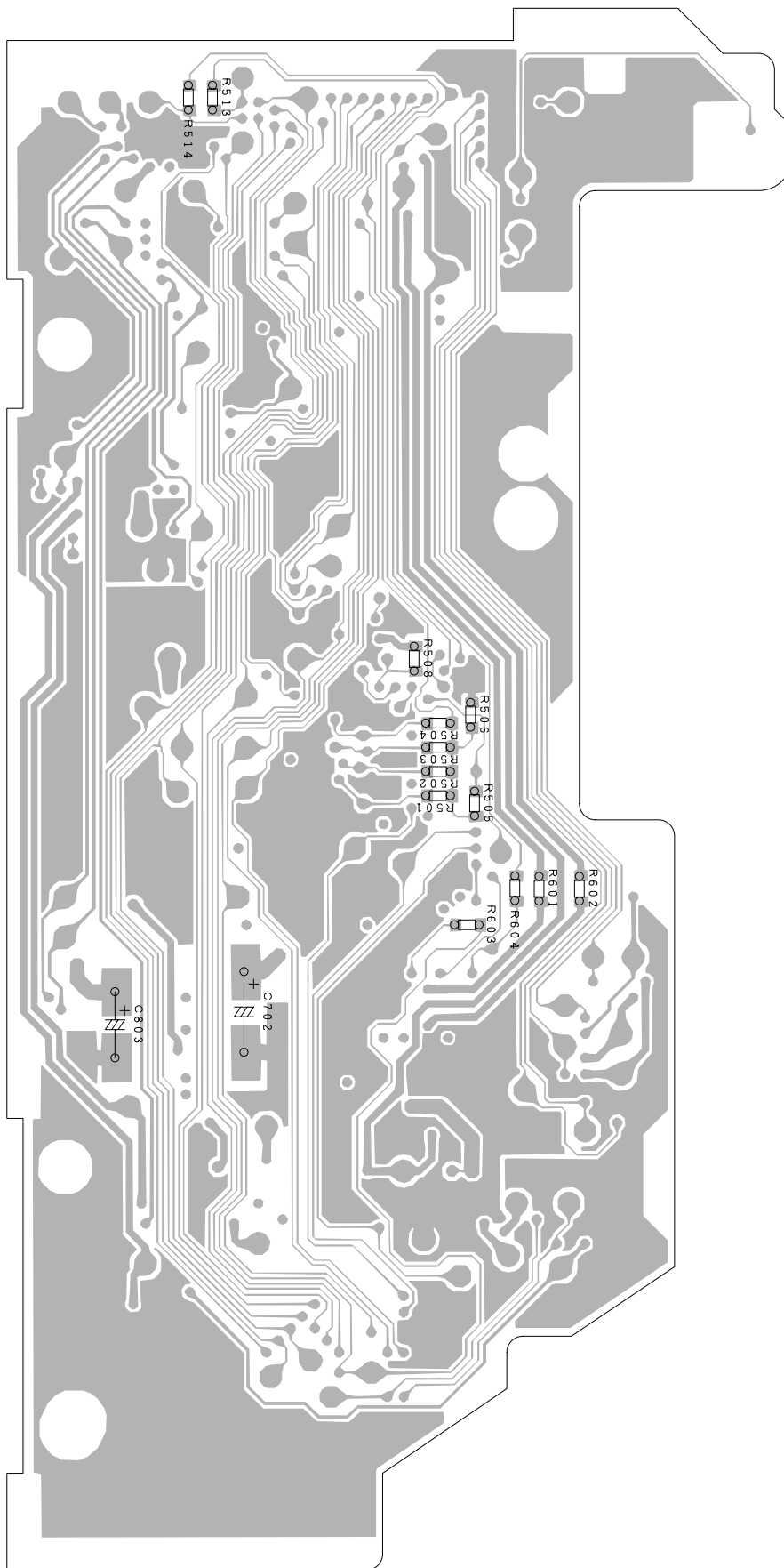

A
B
C
D

4.6 MOTOR PCB(A)

SIDE A

F MOTOR PCB(A)

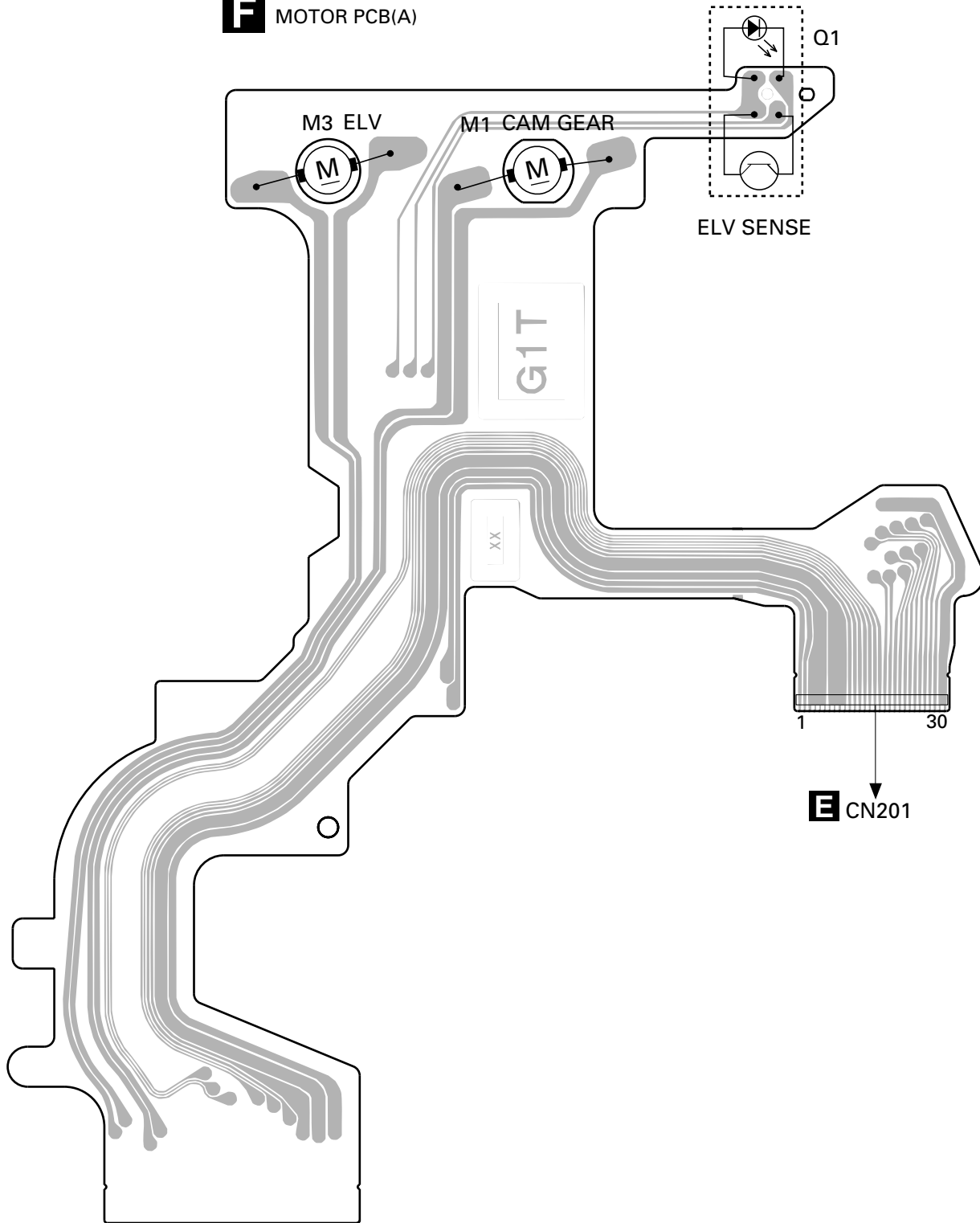

F MOTOR PCB(A)

SIDE B

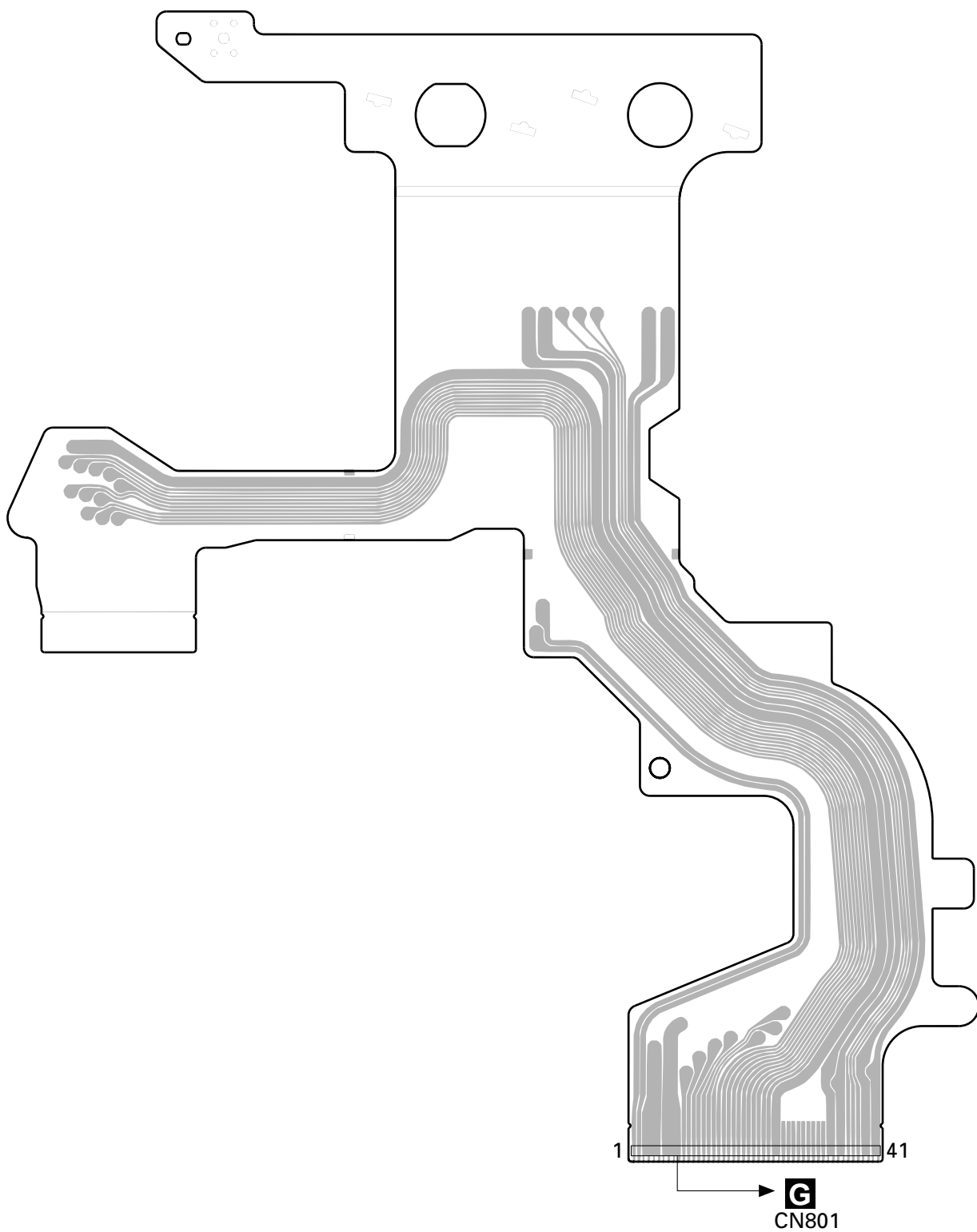

4.7 MOTOR PCB(B)

D MOTOR PCB(B)

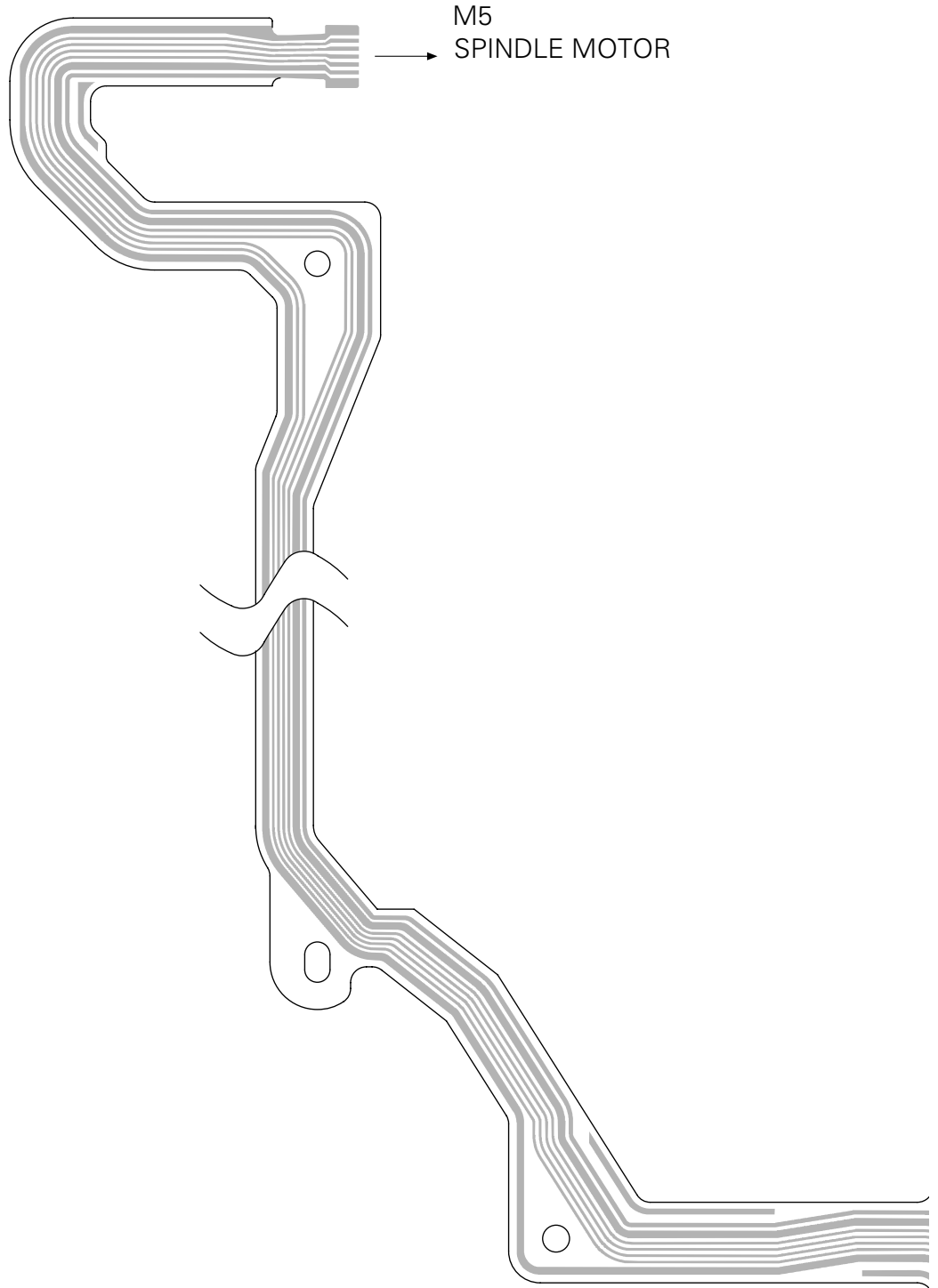

A

B

C

D

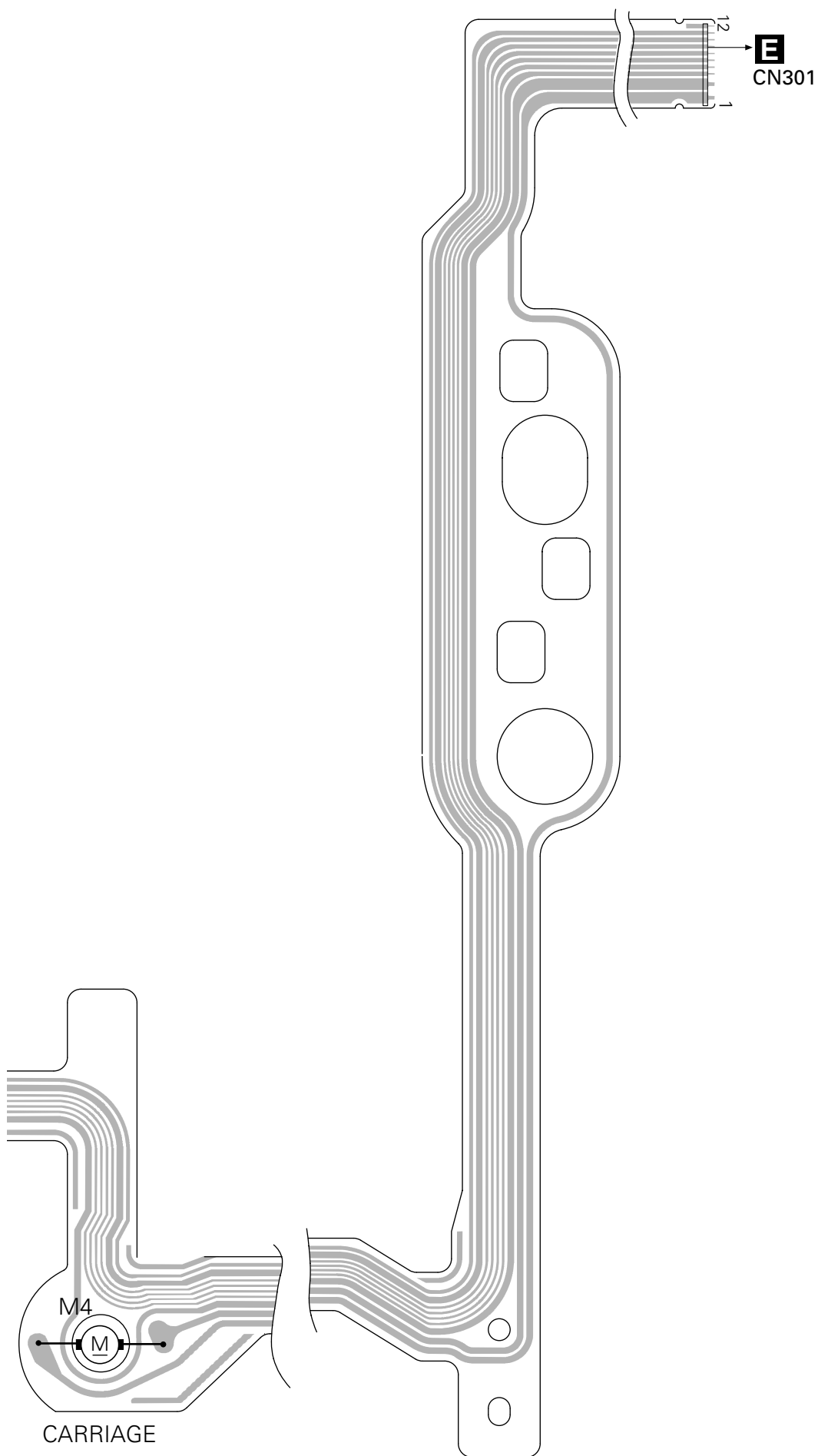

A

B

C

D

4.8 PCB UNIT(B)

4.8 PCB UNIT(D)

A



B

C

D

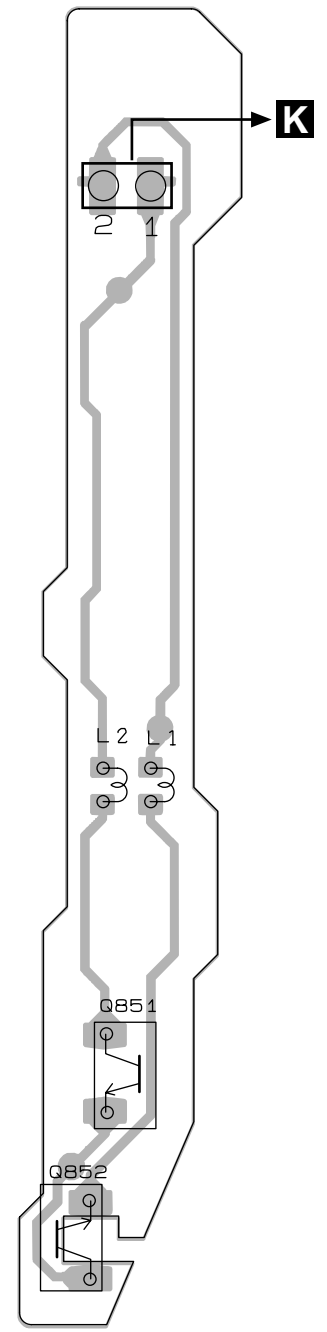
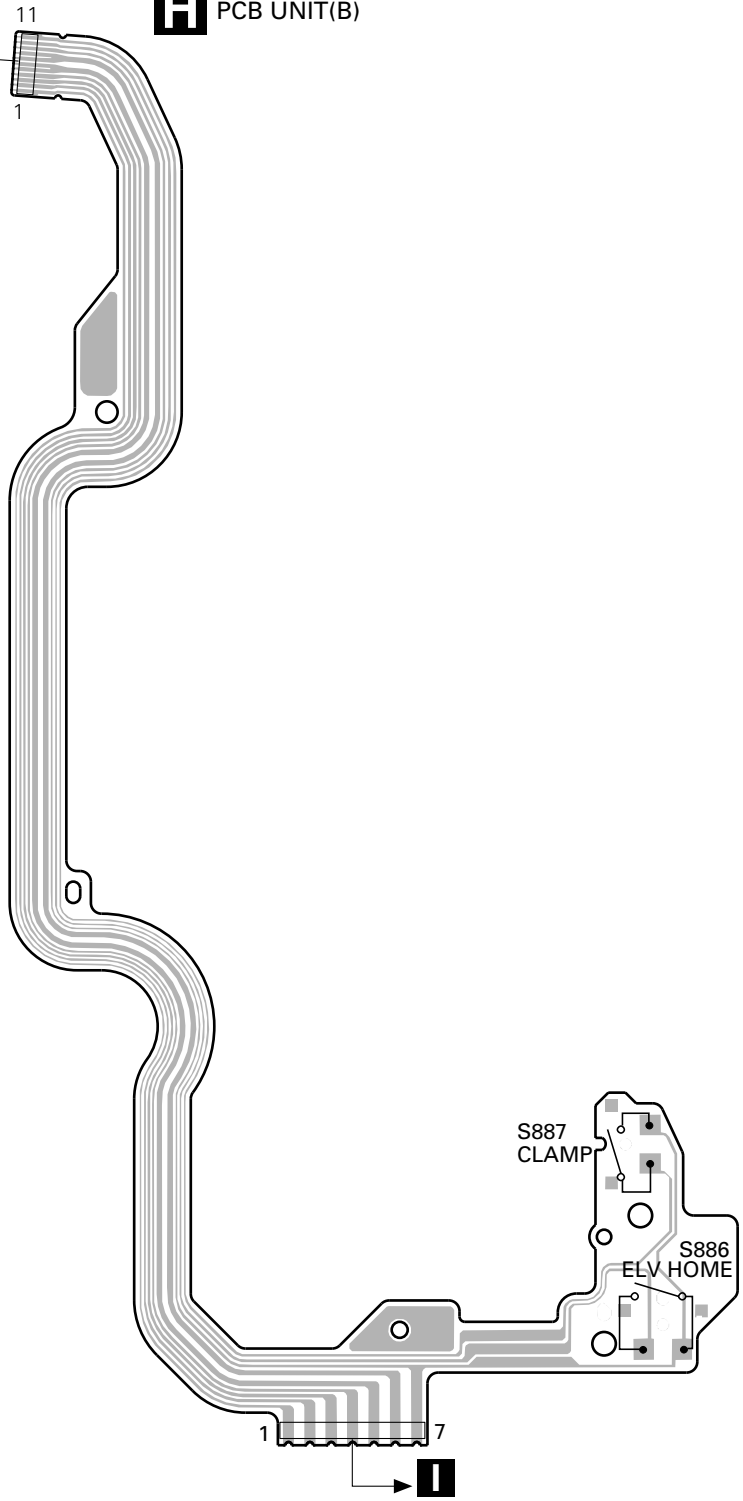

4.10 PCB UNIT(C)

J PCB UNIT(C)

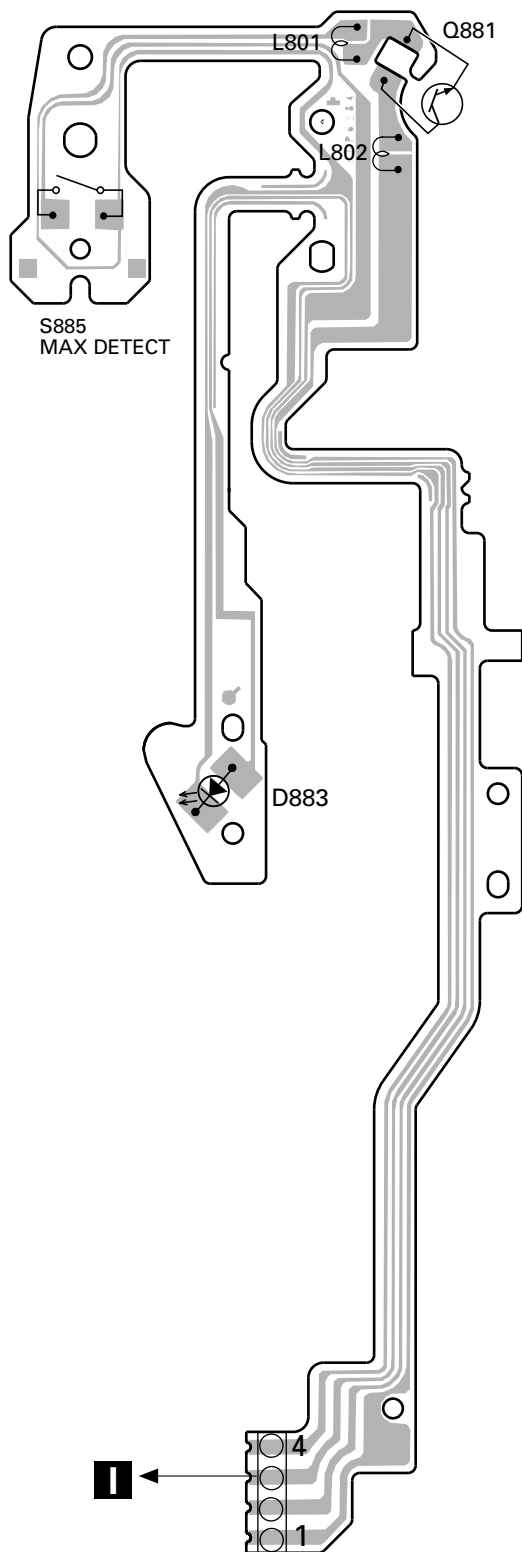

4.11 LOAD MOTOR PCB

A

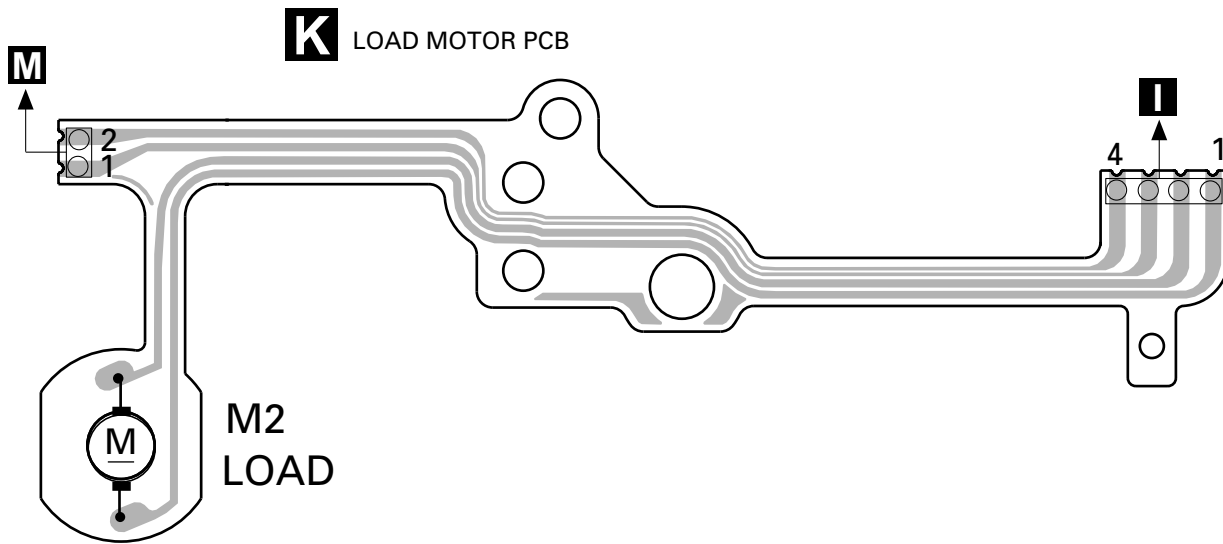

B

4.12 PCB UNIT(A)

C

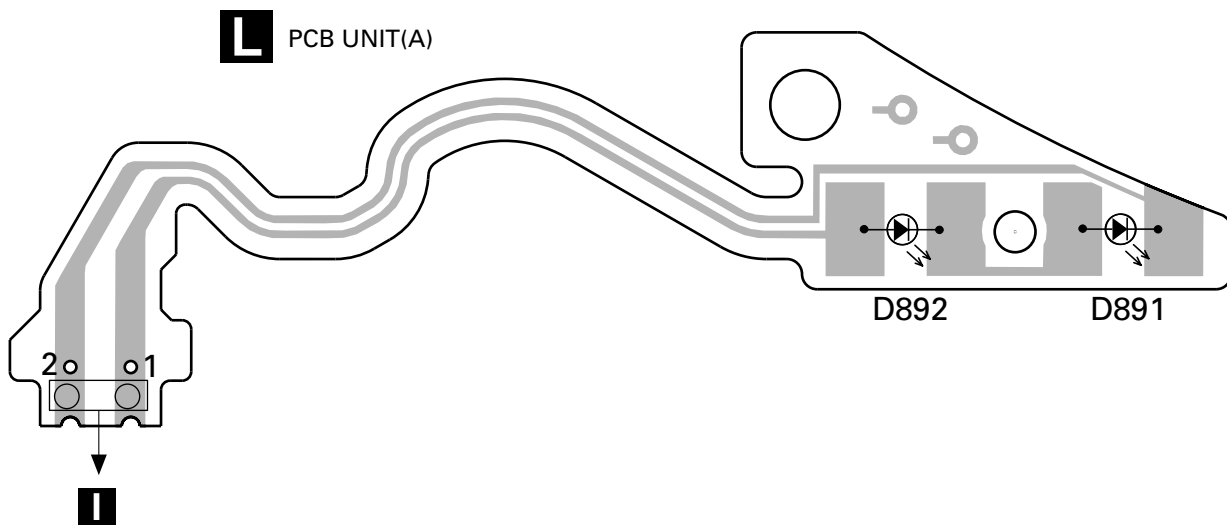

D

4.13 PCB UNIT(E)

I PCB UNIT(E)

I PCB UNIT(E)

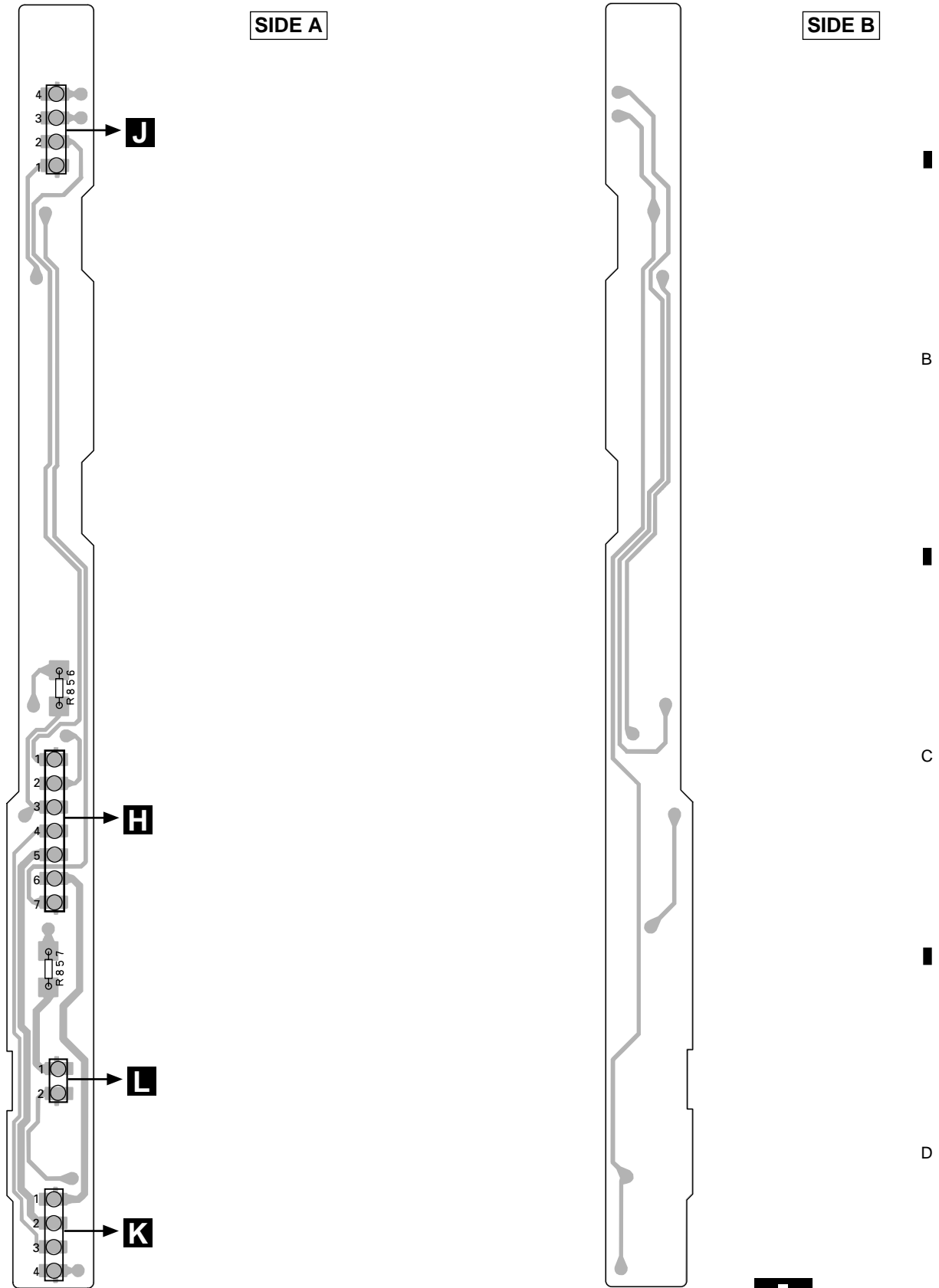

4.14 DECK UNIT

N DECK UNIT

A CN301

SIDE A

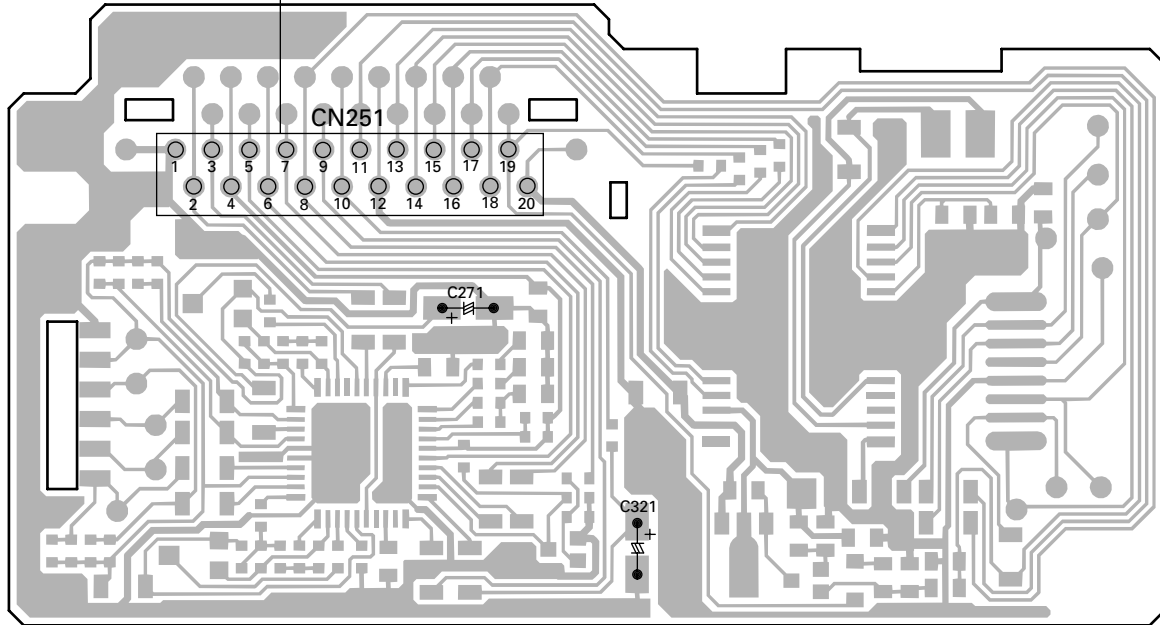

N DECK UNIT

SIDE B

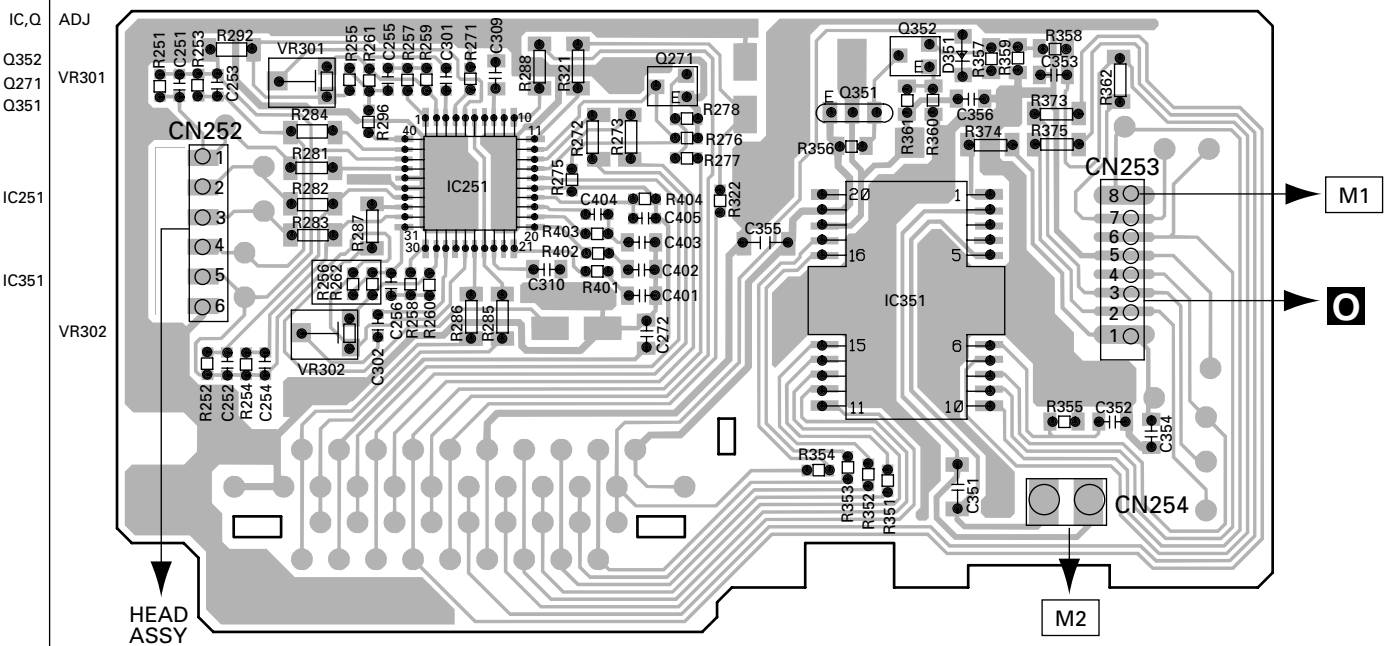

4.15 PCB UNIT

O PCB UNIT

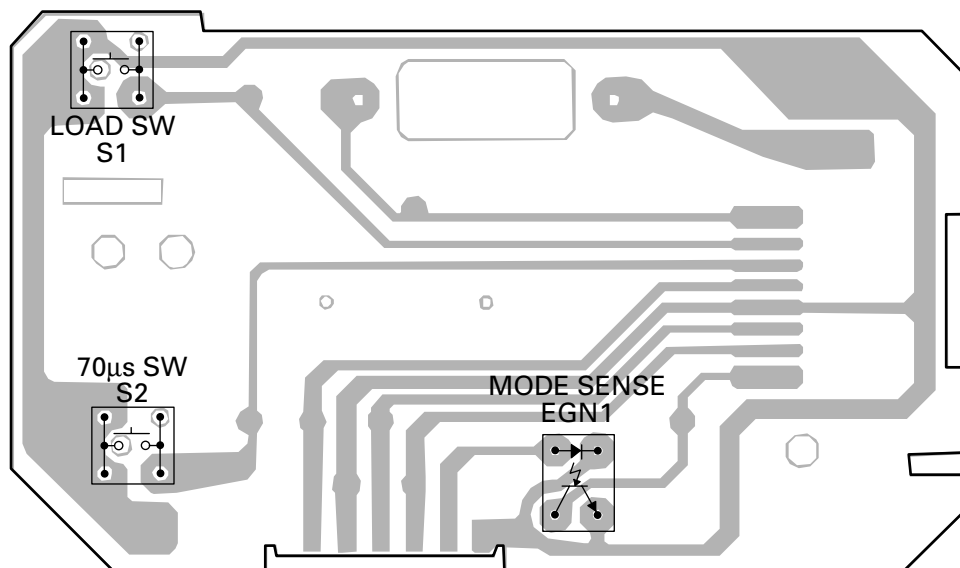

SIDE A

O PCB UNIT

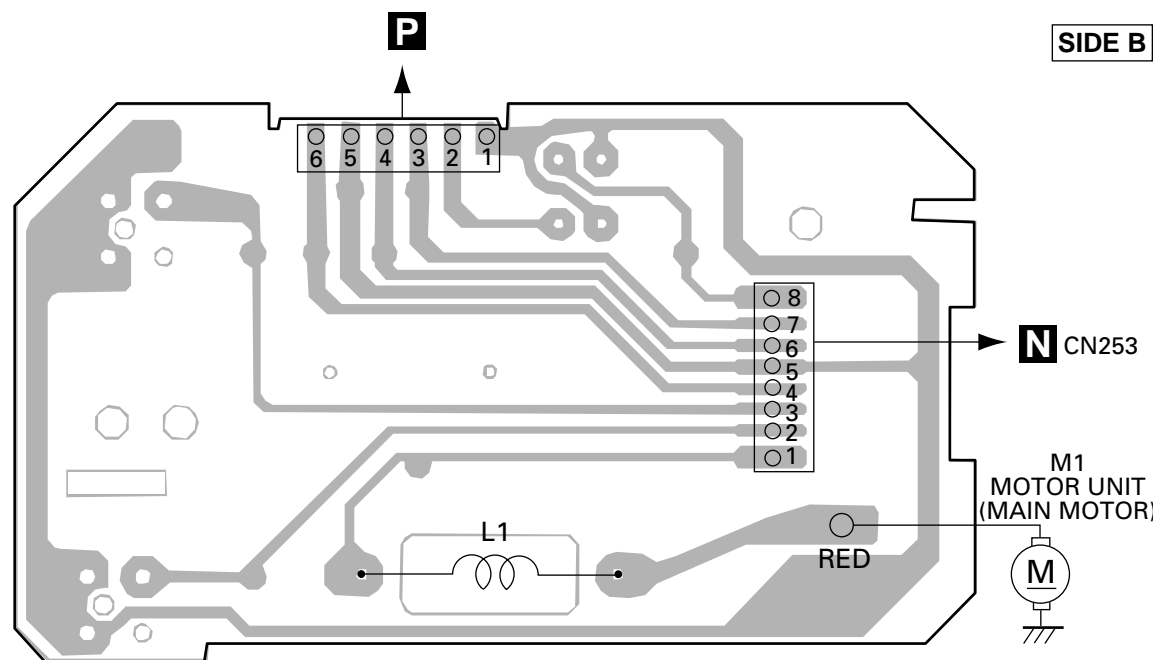

SIDE B

4.16 REEL PCB

P REEL PCB

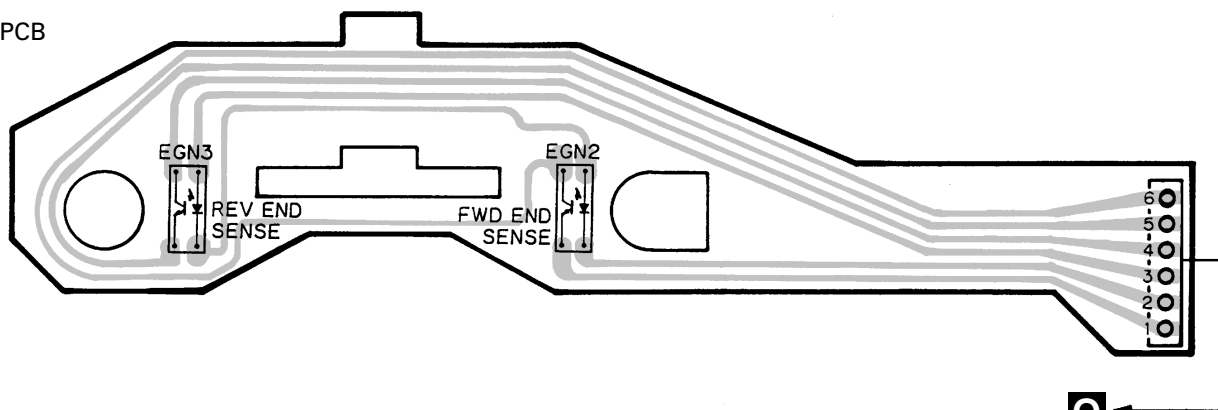

O P

4.17 CONTROL UNIT

SIDE A

A
B
C
D

CONTROL UNIT

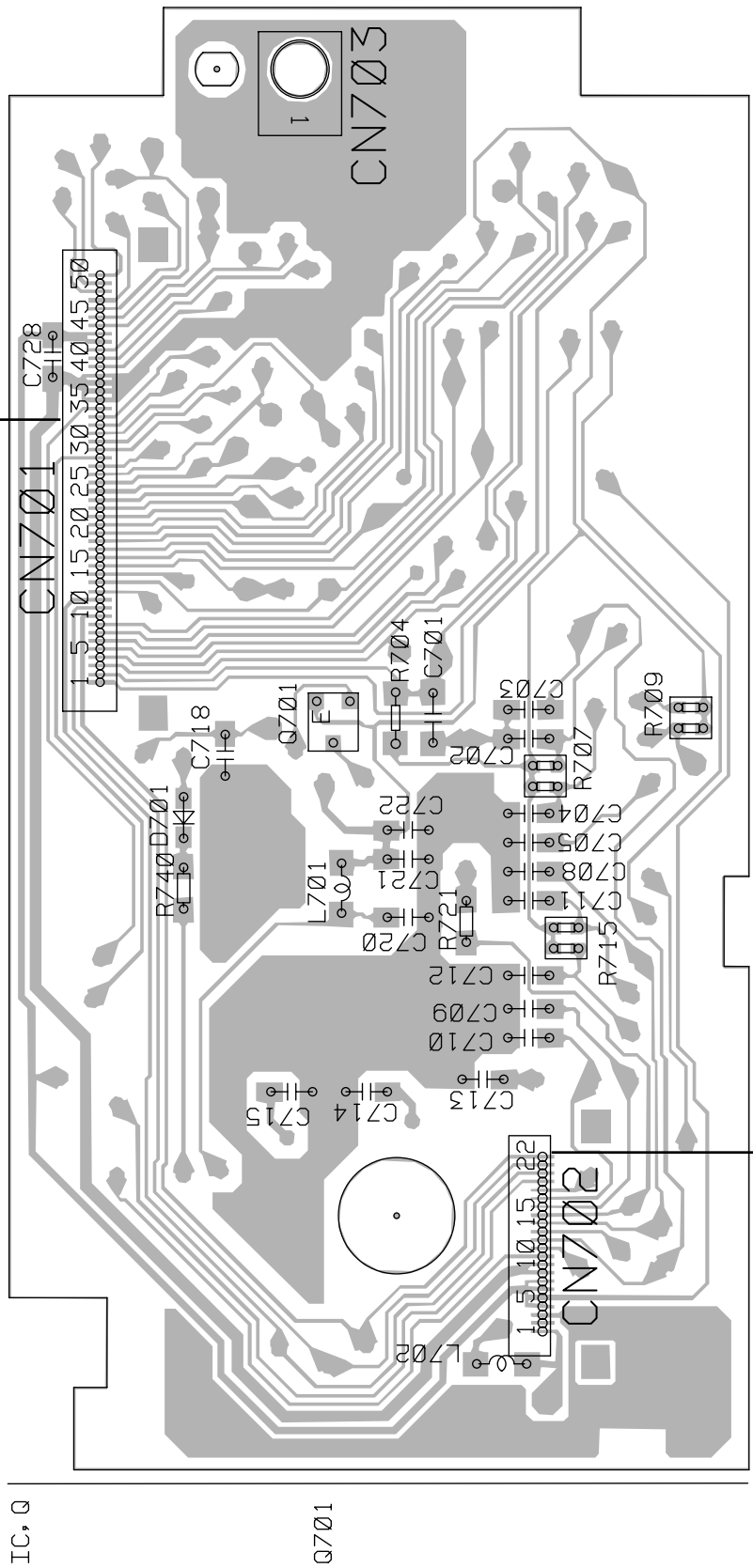

G CN701

A CN303

SIDE B

Q CONTROL UNIT

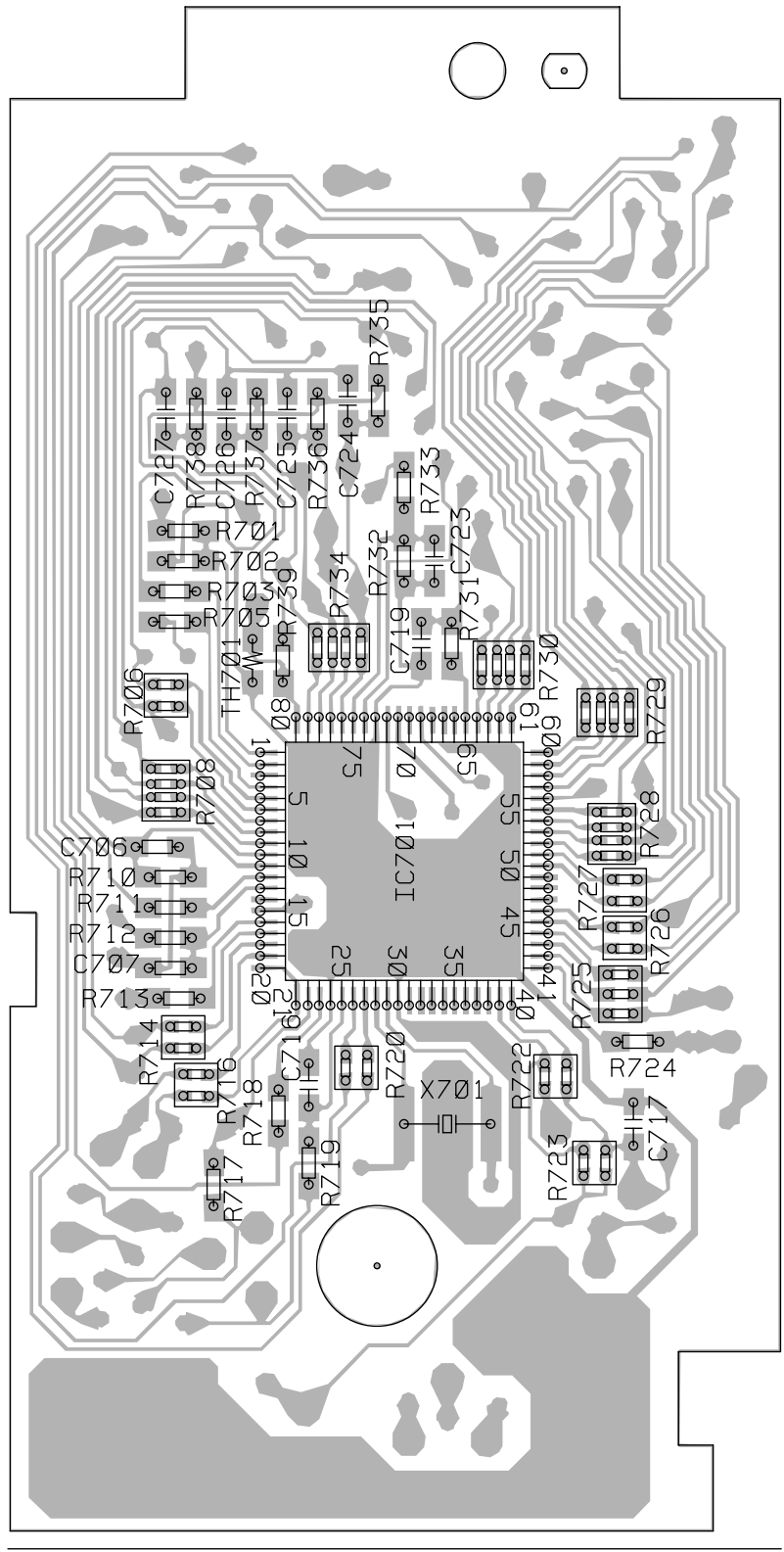

IC, Q

IC701

A
B
C
D

Q

5. ELECTRICAL PARTS LIST

NOTES:

- Parts whose parts numbers are omitted are subject to being not supplied.
- The part numbers shown below indicate chip components.

Chip Resistor

RS1/OSOOOJ, RS1/OOSOOOJ

Chip Capacitor (except for CQS.....)

CKS....., CCS....., CSZS.....

====Circuit Symbol and No.===Part Name Part No. =====Circuit Symbol and No.===Part Name Part No.

B Unit Number : CWE1591
Unit Name : FM/AM Tuner Unit

MISCELLANEOUS

IC	1	IC	PA4026A
IC	2	IC	PA4024A
Q	1	Chip Transistor	2SC2712
Q	3	FET	3SK263
Q	31	Chip Transistor	2SC2712
Q	151	Transistor	DTC144EU
Q	165	Transistor	2SC4116
Q	201	Transistor	FC12
Q	203	Transistor	DTC124EU
D	3	Diode	1SV251
D	4	Diode	1SV250
D	5	Diode	KV1410-F1
D	6	Diode	MA157
D	7	Diode	KV1410-F1
D	8	Diode	KV1410-F1
D	201	Diode	MA157
D	202	Diode	1SV251
D	231	Diode	SVC253
L	1	Inductor	LCTBR12K2125
L	2	Coil	CTC1145
L	3	Inductor	LCTB4R7K2125
L	4	Coil	CTC1131
L	5	Coil	CTC1147
L	40	Inductor	LCTBR15K1608
L	51	Ferri-Inductor	LAU150K
L	52	Coil	CTC1136
L	201	Ferri-Inductor	LAU4R7K
L	202	Ferri-Inductor	LAU330K
L	203	Inductor	CTF1371
L	208	Inductor	LAU390K
L	209	Ferri-Inductor	LAU680K
L	210	Coil	CTB1102
L	231	Inductor	LAU3R3J
T	31	Coil	CTE1116
TC	1	Trimmer	CCL1046
CF	25	Ceramic Filter	CTF1292
CF	51	Ceramic Filter	CTF1292
CF	52	Ceramic Filter	CTF1292
CF	53	Ceramic Filter	CTF1292
CF	230	Crystal Filter	CTF1262
CF	232	Ceramic Filter	CTF1348
X	151	Radiator 918.5Hz	CSS1365
X	231	Crystal Resonator 10.26MHz	CSS1111
VR	101	Semi-fixed 15kΩ(B)	CCP1230
VR	151	Semi-fixed 10kΩ(B)	CCP1229
VR	154	Semi-fixed 150kΩ(B)	CCP1236
VR	156	Semi-fixed 68kΩ(B)	CCP1234

RESISTORS

R	3	RS1/16S223J
R	4	RS1/16S101J
R	5	RS1/16S151J
R	6	RS1/16S101J
R	7	RS1/10S331J
R	8	RS1/16S332J
R	9	RS1/16S473J
R	10	RS1/16S223J
R	11	RS1/16S124J
R	12	RS1/16S474J
R	15	RS1/16S271J
R	16	RS1/16S104J
R	17	RS1/16S332J
R	18	RS1/16S332J
R	19	RS1/16S154J
R	27	RS1/16S0R0J
R	31	RS1/16S470J
R	32	RS1/16S912J
R	33	RS1/16S912J
R	34	RS1/16S331J
R	35	RS1/16S331J
R	39	RS1/16S0R0J
R	51	RS1/16S331J
R	55	RS1/16S102J
R	56	RS1/16S823J
R	61	RS1/16S392J
R	62	RS1/16S393J
R	103	RS1/16S333J
R	104	RS1/16S334J
R	105	RS1/16S683J
R	107	RS1/16S222J
R	152	RS1/16S393J
R	155	RS1/16S393J
R	157	RS1/10S203J
R	160	RS1/16S222J
R	161	RS1/16S563J
R	162	RS1/16S225J
R	163	RS1/16S222J
R	164	RS1/16S563J
R	165	RS1/16S102J
R	202	RS1/16S223J
R	203	RS1/16S225J
R	204	RS1/16S103J
R	205	RS1/16S471J
R	206	RS1/16S220J
R	207	RS1/16S101J
R	208	RS1/16S102J
R	209	RS1/16S0R0J
R	214	RS1/16S563J
R	215	RS1/16S473J
R	217	RS1/16S393J
R	220	RS1/10S0R0J
R	231	RS1/16S242J
R	232	RS1/16S473J
R	233	RS1/16S0R0J

FX-MG8156ZT, MG8156ZT-91, MG8317ZT, MG8317ZT-91

====Circuit Symbol and No.====Part Name	Part No.	====Circuit Symbol and No.====Part Name	Part No.
Q 501	Transistor	IMX1	D 809 Diode
Q 503	Chip Transistor	2SC2712	D 810 Diode
Q 504	Transistor	DTC114EU	D 811 Diode
Q 505	Transistor	2SD2351	D 812 Diode
Q 506	Transistor	DTC114EU	D 813 Diode
Q 507	Transistor	DTC114EU	D 814 Diode
Q 551	Chip Transistor	2SC2712	D 818 Diode
Q 601	Transistor	2SA1162	D 821 Diode
Q 603	Transistor	DTA144EK	D 871 Diode
Q 604	Transistor	DTA114EK	D 891 Diode
Q 607	Transistor	DTA114EK	D 892 Diode
Q 702	Transistor	DTA114EK	L 201 Chip-Inductor
Q 801	Transistor	DTC114EK	L 202 Inductor
Q 802	Transistor	IMX1	L 251 Inductor
Q 804	Transistor	2SD1664	L 501 Inductor
Q 805	Transistor	DTC144TK	L 502 Inductor
Q 806	Transistor	DTC144TK	L 503 Inductor
Q 807	Transistor	DTC144TK	L 504 Inductor
Q 808	Transistor	2SB1184F5	L 511 Inductor
Q 809	Transistor	2SB1185	L 512 Inductor
Q 811	Transistor	2SB1185	L 513 Inductor
Q 812	Transistor	2SB1185	L 515 Inductor
Q 813	Transistor	2SA1162	L 516 Inductor
Q 814	Transistor	2SA1162	L 551 Inductor
Q 815	Transistor	IMX1	L 601 Inductor
Q 816	Transistor	IMX1	L 801 Coil 350µH
Q 818	Transistor	2SB1184F5	CG 501 Surge Protector
Q 819	Transistor	2SA1162	CG 502 Surge Protector
Q 820	Transistor	IMX1	X 201 Crystal Resonator 7.200MHz
Q 822	Transistor	2SB1132	X 251 Crystal Resonator 4.332MHz
Q 823	Transistor	DTC123EK	X 601 Radiator 10.00MHz
Q 825	Transistor	2SA1162	VR 251 2.2kΩ(B)
Q 829	Transistor	2SB1188	VR 552 10kΩ(B)
Q 830	Transistor	DTC123YK	FU 801 Fuse 5A
Q 831	Transistor	DTA114EK	FM/AM Tuner Unit
Q 861	Transistor	2SB1132	
Q 862	Transistor	2SB1132	
Q 863	Transistor	2SB1132	
Q 864	Transistor	IMX1	
Q 871	Transistor	2SA1162	
Q 872	Transistor	DTC144EK	
Q 891	Transistor	2SA1162	
Q 892	Transistor	2SA1162	
Q 893	Transistor	DTC144EK	
Q 894	Transistor	DTC144EK	
D 201	Diode	1SS355	
D 301	Diode	UDZ20(B)	
D 302	Diode	UDZ20(B)	
D 303	Diode	UDZ20(B)	
D 304	Diode	UDZ20(B)	
D 305	Diode	HZU4LL(C)	
D 306	Diode	HZU8R2(B3)	
D 400	Diode	1SS355	
D 501	Diode	1SV241	
D 502	Diode	1SV241	
D 503	Diode	DAP202K	
D 507	Diode	1SS355	
D 519	Diode	DAN202K	
D 605	Diode	1SS355	
D 611	Diode	UDZ18(B)	
D 612	Diode	UDZ18(B)	
D 655	Diode	DAN202K	
D 801	Diode	1SS355	
D 802	Diode	UDZS5R6(B)	
D 803	Diode	RM4LFJ10	
D 804	Diode	1SS355	
D 805	Diode	UDZ20(B)	
D 806	Diode	ERA15-02VH	
D 807	Diode	UDZS5R6(B)	
D 808	Diode	HZU8R2(B1)	
RESISTORS			
		R 200	RS1/10S183J
		R 201	RS1/10S473J
		R 202	RS1/10S102J
		R 203	RS1/10S222J
		R 204	RS1/10S222J
		R 205	RS1/10S103J
		R 206	RS1/10S473J
		R 207	RS1/10S102J
		R 208	RS1/10S102J
		R 209	RS1/10S123J
		R 210	RS1/10S472J
		R 211	RS1/10S682J
		R 212	RS1/10S222J
		R 213	RS1/10S682J
		R 214	RS1/10S102J
		R 215	RS1/10S472J
		R 216	RS1/10S561J
		R 217	RS1/10S682J
		R 218	RS1/10S472J
		R 219	RS1/10S152J
		R 220	RS1/10S392J
		R 221	RS1/10S222J
		R 222	RS1/10S392J
		R 223	RS1/10S272J
		R 224	RS1/10S102J
		R 225	RS1/10S102J
		R 226	RS1/10S102J
		R 227	RS1/10S102J
		R 228	RS1/10S103J
		R 229	RS1/10S473J

FX-MG8156ZT, MG8156ZT-91, MG8317ZT, MG8317ZT-91

====Circuit Symbol and No.====Part Name	Part No.	====Circuit Symbol and No.====Part Name	Part No.
R 231	RS1/10S105J	R 408	RS1/10S222J
R 232	RS1/10S151J	R 409	RS1/10S222J
R 233	RS1/10S0R0J	R 411	RS1/10S223J
R 251	RS1/10S102J	R 412	RS1/10S223J
R 252 1kΩ	CCN1120	R 413	RS1/10S153J
R 256	RS1/10S102J	R 414	RS1/10S153J
R 257	RS1/10S102J	R 415	RS1/10S103J
R 258	RS1/10S0R0J	R 416	RS1/10S103J
R 259	RS1/10S333J	R 434	RS1/10S224J
R 260	RS1/10S104J	R 435	RS1/10S224J
R 261	RS1/10S104J	R 436	RS1/10S224J
R 262	RS1/10S681J	R 437	RS1/10S222J
R 263	RS1/10S684J	R 438	RS1/10S222J
R 264	RS1/10S222J	R 501	RS1/10S104J
R 265	RS1/10S222J	R 502	RS1/10S103J
R 266	RS1/10S562J	R 503	RS1/10S103J
R 267	RS1/10S222J	R 504	RS1/10S334J
R 268	RS1/10S102J	R 505	RS1/10S101J
R 271	RS1/10S562J	R 506	RS1/10S101J
R 301	RS1/10S182J	R 507	RS1/10S104J
R 302	RS1/10S182J	R 508	RS1/10S104J
R 303	RS1/10S473J	R 509	RS1/10S103J
R 304	RS1/10S473J	R 510	RS1/10S182J
R 307	RS1/10S363J	R 511	RS1/10S683J
R 308	RS1/10S363J	R 512	RS1/10S153J
R 309	RS1/10S473J	R 513	RS1/10S103J
R 310	RS1/10S473J	R 514	RS1/10S224J
R 311	RS1/10S563J	R 515	RS1/10S473J
R 312	RS1/10S563J	R 516	RS1/10S473J
R 313	RS1/10S102J	R 517	RS1/10S102J
R 314	RS1/10S102J	R 519	RS1/10S393J
R 315	RS1/10S473J	R 521	RS1/10S103J
R 316	RS1/10S473J	R 522	RS1/10S913J
R 319	RS1/10S223J	R 523	RS1/10S223J
R 320	RS1/10S223J	R 525	RS1/10S103J
R 321	RS1/10S223J	R 530	RS1/10S225J
R 322	RS1/10S223J	R 531	RS1/10S225J
R 323	RS1/10S222J	R 532	RS1/10S225J
R 324	RS1/10S222J	R 533	RS1/10S225J
R 325	RS1/10S222J	R 536	RS1/10S472J
R 326	RS1/10S222J	R 537	RS1/10S471J
R 327	RS1/10S510J	R 538	RS1/10S102J
R 328	RS1/10S510J	R 541	RS1/10S103J
R 329	RS1/10S510J	R 570	RS1/10S104J
R 330	RS1/10S510J	R 571	RS1/10S123J
R 333	RS1/10S510J	R 572	RS1/10S105J
R 334	RS1/10S510J	R 573	RS1/10S682J
R 335	RS1/10S510J	R 574	RS1/10S822J
R 336	RS1/10S510J	R 575	RS1/10S222J
R 337	RS1/10S103J	R 576	RS1/10S184J
R 339	RS1/10S392J	R 577	RS1/10S223J
R 340	RS1/10S392J	R 578	RS1/10S473J
R 341	RS1/10S473J	R 601	RS1/10S102J
R 342	RS1/10S473J	R 602	RS1/10S222J
R 343	RS1/10S472J	R 603	RS1/10S222J
R 344	RS1/10S102J	R 604	RS1/10S471J
R 345	RS1/10S223J	R 605	RA3C102J
R 346	RS1/10S103J	R 607	RS1/10S473J
R 347	RS1/10S104J	R 608	RS1/10S102J
R 348	RS1/10S153J	R 609	RS1/10S681J
R 349	RS1/10S392J	R 610	RS1/10S102J
R 351	RS1/10S0R0J	R 611	RS1/10S473J
R 352	RS1/10S0R0J	R 612	RA2CQ102J
R 353	RS1/10S0R0J	R 613	RS1/10S473J
R 401	RS1/10S103J	R 614	RS1/10S0R0J
R 402	RS1/10S103J	R 616	RS1/10S473J
R 403	RS1/10S222J	R 617	RS1/10S102J
R 405	RS1/10S102J	R 618	RS1/10S472J
R 406	RS1/10S102J	R 619	RA2CQ102J
R 407	RS1/10S222J	R 620	RA2CQ473J

FX-MG8156ZT, MG8156ZT-91, MG8317ZT, MG8317ZT-91

====Circuit Symbol and No.====Part Name	Part No.	====Circuit Symbol and No.====Part Name	Part No.
C 260	CKSQYB105K16	C 510	CKSQYB472K50
C 261	CKSQYB104K50	C 511	CEAL100M16
C 262	CKSQYB222K50	C 512	CKSQYB473K50
C 264	CKSQYB103K50	C 513	CEAL2R2M50
C 265	CKSQYB103K50	C 514	CKSQYB102K50
C 266	CKSQYB223K50	C 515	CKSQYB103K50
C 267	CKSQYB104K50	C 516	CKSQYB103K50
C 301	4.7μF/35V CCH1016	C 517	CKSQYB392K50
C 302	4.7μF/35V CCH1016	C 519	CKSQYB472K50
C 305	4.7μF/35V CCH1016	C 521	CKSQYB222K50
C 306	4.7μF/35V CCH1016	C 522	CKSQYB104K25
C 307	4.7μF/35V CCH1016	C 523	CKSQYB102K50
C 308	4.7μF/35V CCH1016	C 535	CKSQYB103K50
C 309	CCSQCH120J50	C 536	CKSQYB103K50
C 310	CCSQCH120J50	C 537	CKSQYB103K50
C 311	4.7μF/35V CCH1016	C 581	CEAL3R3M50
C 312	4.7μF/35V CCH1016	C 582	CKSQYB333K50
C 313	4.7μF/35V CCH1016	C 583	CEALNP1R0M50
C 314	4.7μF/35V CCH1016	C 584	CQMA683J50
C 315	CCSQCH330J50	C 585	QOMA333J50
C 316	CCSQCH330J50	C 586	CQMA333J50
C 317	CKSQYB331K50	C 587	CQMA333J50
C 318	CKSQYB331K50	C 588	CKSQYB183K50
C 319	CKSQYB682K50	C 589	CKSQYB682K50
C 320	CKSQYB682K50	C 590	CKSQYB682K50
C 321	CKSQYB682K50	C 591	CKSQYB392K50
C 322	CKSQYB682K50	C 592	CKSQYB102K50
C 323	CEALNP4R7M16	C 593	CKSQYB334K16
C 324	CEALNP4R7M16	C 594	CKSQYB334K16
C 325	CEALNP4R7M16	C 601	CKSQYB102K50
C 326	CEALNP4R7M16	C 603	CEAL100M16
C 327	CCSQCH101J50	C 604	CKSQYB104K50
C 328	CCSQCH101J50	C 605	CKSQYB103K50
C 329	CCSQCH101J50	C 606	CCSQCH101J50
C 330	CCSQCH101J50	C 607	CCSQCH101J50
C 331	CKSQYB224K16	C 608	CCSQCH101J50
C 333	CKSQYB103K50	C 609	CCSQCH101J50
C 334	CEAL101M6R3	C 610	CCSQCH101J50
C 335	CEJA470M10	C 611	CCSQCH101J50
C 336	CKSQYB103K50	C 612	CCSQCH101J50
C 337	CEAL4R7M35	C 615	CCSQCH101J50
C 339	4.7μF/35V CCH1016	C 616	CCSQCH101J50
C 340	4.7μF/35V CCH1016	C 619	CCSQCH101J50
C 341	CEAL100M16	C 625	CKSQYB103K50
C 343	CCSQCH101J50	C 626	CKSQYB103K50
C 344	CCSQCH101J50	C 627	CKSQYB221K50
C 401	CKSQYB683K25	C 628	CKSQYB221K50
C 402	CKSQYB683K25	C 648	CKSQYB102K50
C 405	CKSQYB103K50	C 650	CKSQYB102K50
C 406	CKSQYB103K50	C 655	CKSQYB473K50
C 407	CKSQYB473K50	C 801	CKSQYB102K50
C 408	CKSQYB473K50	C 802	CEAL1R0M50
C 413	4.7μF/35V CCH1016	C 803	CKSQYB102K50
C 414	4.7μF/35V CCH1016	C 804	CCH1186
C 415	CCSQCH101J50	C 805	CKSQYB473K50
C 416	CCSQCH101J50	C 806	CKSQYB102K50
C 434	CKSQYB153K50	C 807	CEAL1R0M50
C 435	CKSQYB563K16	C 808	CKSQYB102K50
C 436	CEJA101M10	C 809	CCH1186
C 503	CKSQYB222K50	C 811	CCSQCH101J50
C 504	CKSQYB222K50	C 812	CKSQYB103K50
C 505	CKSQYB222K50	C 813	CEJA221M6R3
C 507	CKSQYB103K50	C 814	CEAL1R0M50
C 508	CKSQYB103K50	C 815	CEAL1R0M50
C 509	CEAL100M16	C 816	CKSQYB103K50

FX-MG8156ZT, MG8156ZT-91, MG8317ZT, MG8317ZT-91

====Circuit Symbol and No.====	Part Name	Part No.
C 817	100µF/10V	CCH1402
C 818		CKSQYB103K50
C 819	100µF/10V	CCH1282
C 820		CKSQYB103K50
C 824		CKSQYB472K50
C 825	100µF/10V	CCH1402
C 826		CKSQYB472K50
C 828		CKSQYB102K50
C 829		CKSQYB103K50
C 830		CKSQYB103K50
C 831		CKSQYB103K50
C 832		CKSQYB103K50
C 861		CKSQYB223K50
C 862		CKSQYB223K50
C 863		CKSQYB223K50
C 871		CKSQYB103K50
C 891		CKSQYB103K50
C 892		CKSQYB103K50

Q Unit Number : CWM7280
Unit Name : Control Unit

MISCELLANEOUS

IC 701	IC	PD5673A
Q 701	Transistor	DTA144EK
D 701	Diode	1SS355
L 701	Inductor	LCTB100K3216
L 702	Inductor	LCTB100K3216
TH 701	Thermistor	CCX1036
X 701	Ceramic Resonator 6.290MHz	CSS1367

RESISTORS

R 701		RS1/10S433J
R 702		RS1/10S103J
R 703		RS1/10S222J
R 704		RS1/8S103J
R 705		RS1/10S102J
R 706		RA2CQ222J
R 707		RA2CQ103J
R 708	330Ω	CCN1116
R 709		RA2CQ222J
R 710		RS1/10S104J
R 711		RS1/10S331J
R 712		RS1/10S103J
R 713		RS1/10S102J
R 714		RA2CQ222J
R 715		RA2CQ103J
R 716		RA2CQ102J
R 717		RS1/10S102J
R 718		RS1/10S471J
R 719		RS1/10S102J
R 720		RA2CQ471J
R 721		RS1/10S102J
R 722		RA2CQ222J
R 723		RA2CQ473J
R 724		RS1/10S102J
R 725		RA3C471J
R 726		RA2CQ102J
R 727		RA2CQ102J
R 728	470Ω	CCN1117
R 729	470Ω	CCN1117
R 730	470Ω	CCN1117
R 731		RS1/10S471J
R 732		RS1/10S912J
R 733		RS1/10S102J
R 734	2.2kΩ	CCN1121
R 735		RS1/10S273J

====Circuit Symbol and No.====	Part Name	Part No.
R 736		RS1/10S512J
R 737		RS1/10S104J
R 738		RS1/10S154J
R 739		RS1/10S183J
R 740		RS1/10S102J

CAPACITORS

C 701		CKSYB102K50
C 702		CKSQYB102K50
C 704		CKSQYB102K50
C 705		CKSQYB102K50
C 706		CKSQYB102K50
C 709		CCSQCH101J50
C 711		CKSQYB102K50
C 712		CKSQYB102K50
C 714		CCSQCH180J50
C 715		CCSQCH180J50
C 716		CKSQYB102K50
C 717		CKSQYB102K50
C 718		CKSQYB102K50
C 719		CKSQYB102K50
C 721		CKSQYB102K50
C 722		CKSQYB105K10
C 723		CKSQYB103K50
C 724		CKSQYB102K50
C 725		CKSQYB102K50
C 726		CKSQYB102K50
C 727		CKSQYB102K50
C 728		CKSQYB102K50

C Unit Number : CWS1333
Unit Name : Keyboard Unit

MISCELLANEOUS

IC 901	IC	LC75804W
Q 901	Transistor	2SB1132
Q 902	Transistor	DTC123YK
D 901	Chip LED	NSCW310-0371
D 902	Chip LED	NSCW310-0371
D 904	Chip LED	NSCW310-0371
D 905	Chip LED	NSCW310-0371
D 907	Diode	DAP202K
D 908	Diode	1SS355
D 909	Diode	1SS355
D 910	Diode	1SS355
D 911	Diode	1SS355
D 912	Diode	1SS355
D 913	LED	SML210FT
D 914	LED	SML210FT
D 920	Diode	HZU4R7(B3)
S 924	Switch(DCLOSE)	CSN1051
IL 901	Lamp 8V 60mA	CEL1685
IL 902	Lamp 8V 60mA	CEL1685
IL 903	Lamp 8V 60mA	CEL1686
IL 904	Lamp 8V 60mA	CEL1686
IL 905	Lamp 8V 60mA	CEL1686
IL 906	Lamp 8V 60mA	CEL1686
IL 907	Lamp 8V 60mA	CEL1685
IL 908	Lamp 8V 60mA	CEL1685
IL 909	Lamp 8V 60mA	CEL1685
IL 910	Lamp 8V 60mA	CEL1685
IL 911	Lamp 8V 60mA	CEL1685
IL 912	Lamp 8V 60mA	CEL1685
IL 913	Lamp 8V 60mA	CEL1685
IL 914	Lamp 8V 60mA	CEL1685
VR 901	Encoder	CSD1048
VR 902	Encoder	CSD1065
LCD 901	LCD	CAW1682

====Circuit Symbol and No.====Part Name	Part No.
RESISTORS	
R 901	RS1/8S241J
R 902	RS1/8S241J
R 904	RS1/8S241J
R 905	RS1/8S241J
R 907	RS1/16S223J
R 908	RS1/16S223J
R 909 1kΩ	CCN1120
R 910 1kΩ	CCN1120
R 912	RS1/16S681J
R 914 1kΩ	CCN1120
R 917	RS1/16S102J
R 918	RS1/16S103J
R 919	RS1/16S223J
R 920	RS1/10S561J
R 921	RS1/10S222J
R 923	RS1/10S222J
R 924	RS1/10S222J
R 925	RS1/16S393J
R 932 1kΩ	CCN1120
R 934	RS1/10S241J
R 935	RS1/10S161J
R 936	RS1/10S241J
R 937	RS1/10S103J
R 940	RS1/10S0R0J
R 941	RS1/10S0R0J

CAPACITORS

C 901	CKSQYB104K50
C 902	CKSQYB104K50
C 904	CKSQYB104K50
C 905	CKSQYB104K50
C 907	CCSRCH101J50
C 908	CCSRCH101J50
C 909	CKSRYB474K10
C 910	CKSRYB103K50
C 911	CKSRYB104K16
C 913	CKSRYB104K16
C 914	CKSRYB104K16
C 917	CKSRYB102K50
C 919	CKSQYB104K50
C 923	CCSRCH101J50
C 924	CCSRCH101J50
C 925	CCSRCH101J50
C 926	CCSRCH101J50

E Unit Number : CWX2421
 Unit Name : CD Core Unit(Servo Unit)

MISCELLANEOUS

IC 101	IC	UPC2572GS
IC 201	IC	UPD63702AGF
IC 301	IC	BA5986FM
Q 101	Transistor	2SD1664
Q 102	Transistor	UMD2N
D 301	Diode	1SR154-400
L 201	Inductor	LCYBR15J1608
L 202	Inductor	LCYBR15J1608
X 201	Ceramic Resonator	16.934MHz
EF 201	Filter	CSS1457
EF 202	Filter	CCG1076

====Circuit Symbol and No.====Part Name	Part No.
RESISTORS	
R 101	RS1/8S100J
R 102	RS1/8S120J
R 104	RS1/16S822J
R 105	RS1/16S682J
R 106	RS1/16S183J
R 107	RS1/16S822J
R 108	RS1/16S333J
R 109	RS1/16S683J
R 110	RS1/16S134J
R 111	RS1/16S273J
R 112	RS1/16S222J
R 113	RS1/16S103J
R 114	RS1/16S103J
R 115	RS1/16S102J
R 116	RS1/16S163J
R 117	RS1/16S163J
R 120	RS1/16S101J
R 121	RS1/16S101J
R 201	RS1/16S104J
R 202	RS1/16S103J
R 203	RS1/16S332J
R 204	RS1/16S752J
R 205	RS1/16S752J
R 206	RS1/16S101J
R 250	RS1/16S331J
R 251	RS1/16S331J
R 252	RS1/16S331J
R 253	RS1/16S331J
R 254	RS1/16S331J
R 255	RS1/16S471J
R 256	RS1/16S471J
R 263	RS1/16S471J
R 270	RS1/16S101J
R 271	RS1/16S101J
R 274	RS1/16S471J
R 277	RS1/16S471J
R 301	RS1/16S103J
R 302	RS1/16S153J
R 303	RS1/16S103J
R 304	RS1/16S273J
R 305	RS1/16S103J
R 306	RS1/16S752J
R 307	RS1/16S103J
R 308	RS1/16S103J
R 309	RS1/16S471J
R 311	RS1/16S471J

CAPACITORS

C 101	CEV101M6R3
C 102	CKSQYB104K16
C 103	CEV470M6R3
C 104	CKSQYB334K16
C 105	CCSRCH240J50
C 106	CKSRYB222K50
C 107	CEV4R7M35
C 108	CKSRYB273K25
C 109	CCSRCH101J50
C 110	CKSQYB104K16
C 111	CKSRYB332K50
C 112	CKSQYB473K16
C 113	CKSRYB103K25
C 114	CKSRYB391K50
C 115	CCSRCH121J50

FX-MG8156ZT, MG8156ZT-91, MG8317ZT, MG8317ZT-91

====Circuit Symbol and No.====Part Name	Part No.
C 116	CKSRYPB682K50
C 117	CKSRYPB333K16
C 118	CKSQYB334K16
C 119	CKSQYB334K16
C 120	CKSQYB334K16
C 121	CKSQYB334K16
C 122	CKSQYB104K16
C 123	CKSRYPB472K50
C 124	CKSQYB104K16
C 125	CCSRCH5R0C50
C 126	CKSRYPB153K25
C 127	CKSRYPB102K50
C 201	CKSQYB334K16
C 202	CKSQYB104K16
C 203	CKSQYB104K16
C 204	CKSRYPB471K50
C 207	CKSQYB683K16
C 208	CKSRYPB821K50
C 209	CKSRYPB273K25
C 210	CKSQYB334K16
C 211	CKSQYB334K16
C 212	CKSQYB334K16
C 213	CCH1349
C 301	CEV101M10
C 302	CEV101M10

10µF/10V

G Unit Number : CWX2422
Unit Name : CD Core Unit(STS Unit)

MISCELLANEOUS

IC 501	IC	CXD2511R
IC 502	IC	MSM514400DP-60TS
IC 601	IC	AK4321VF
IC 701	IC	BA05SFP
IC 801	IC	LB1836M
IC 802	IC	LB1836M
Q 801	Transistor	DTA123JK
Q 802	Transistor	UN2211
D 701	Diode	1SR154-400
D 702	Diode	1SR154-400
D 703	Diode	1SS355
D 704	Diode	1SS355
D 705	Diode	1SS355
D 706	Diode	1SS355
D 707	Diode	1SS355
D 708	Diode	1SS355
S 801	Spring Switch(LOAD)	CSN1052
S 802	Spring Switch(DOOR)	CSN1052
S 803	Spring Switch(MODE)	CSN1052
EF 701	Filter	CCG1051
EF 702	Filter	CCG1051
EF 703	Filter	CCG1051

RESISTORS

R 501	RS1/16S102J
R 502	RS1/16S202J
R 503	RS1/16S392J
R 504	RS1/16S822J
R 505	RS1/16S163J
R 506	RS1/16S512J
R 507	RS1/16S182J
R 508	RS1/16S222J
R 509	RS1/16S102J
R 510	RS1/16S102J
R 511	RS1/16S102J
R 512	RS1/16S102J
R 513	RS1/16S102J
R 514	RS1/16S471J
R 601	RS1/16S101J

====Circuit Symbol and No.====Part Name	Part No.
R 602	RS1/16S101J
R 603	RS1/16S471J
R 604	RS1/16S471J
R 702	RS1/10S100J
R 716	RS1/16S471J
R 717	RS1/16S471J
R 718	RS1/16S471J
R 801	RS1/10S102J

CAPACITORS

C 501	CKSQYB334K16
C 502	CKSQYB334K16
C 503	CKSQYB334K16
C 504	CCSRCH471J50
C 506	CCSRCH221J50
C 601	CKSQYB334K16
C 602	CCSRCH221J50
C 603	CKSQYB334K16
C 604	CKSQYB334K16
C 605	CSZSR100M10
C 606	CKSQYB334K16
C 701	10µF/10V
C 702	CCH1349
C 703	CEV101M10
C 704	CKSQYB334K16

C 705	CCSRCH151J50
C 706	CCSRCH151J50
C 707	CCSRCH151J50
C 801	CKSQYB104K25
C 802	CKSQYB104K25

C 803	CEVL220M16
-------	------------

L Unit Number :
Unit Name : PCB Unit(A)

D 891	Chip LED	CL205IRXTU
D 892	Chip LED	CL205IRXTU

H Unit Number :
Unit Name : PCB Unit(B)

S 886	Spring Switch(ELV Home)	CSN1052
S 887	Spring Switch(Clamp)	CSN1051

J Unit Number :
Unit Name : PCB Unit(C)

Q 881	Photo-transistor	CPT230SCTD
D 883	Chip LED	CL205IRXTU
S 885	Spring Switch(MAX DETECT)	CSN1052
L 801	Inductor	LCYBR15J1608
L 802	Inductor	LCYBR15J1608

M Unit Number :
Unit Name : PCB Unit(D)

Q 851	Photo-transistor	CPT230SCTD
Q 852	Photo-transistor	CPT230SCTD
L 1	Inductor	LCYBR15J1608
L 2	Inductor	LCYBR15J1608

I Unit Number :
Unit Name : PCB Unit(E)

R 856	RS1/8S911J
R 857	RS1/8S821J

F Unit Number :
Unit Name : Motor PCB(A)

Q 1	Photo-interrupter	RPI-221
M 1	Motor Unit(Cam Gear)	CXB6929
M 3	Motor Unit(ELV)	CXB3175

====Circuit Symbol and No.====Part Name Part No.

D Unit Number :
Unit Name : Motor PCB(B)
M 4 Motor Unit(Carriage) CXB3178
M 5 Motor(Spindle) CXM1120

K Unit Number :
Unit Name : Load Motor PCB
M 2 Motor Unit(Load) CXB3177

N Unit Number : EWM1030
Unit Name : Deck Unit

MISCELLANEOUS

IC 251 IC HA12216F
IC 351 IC PA2020A
Q 271 Transistor 2SC4116
Q 351 Transistor 2SB1260
Q 352 Transistor 2SC4102
D 351 Diode 1SS355
VR 301 Semi-fixed 33kΩ(B) CCP1280
VR 302 Semi-fixed 33kΩ(B) CCP1280

RESISTORS

R 255 RS1/16S181J
R 256 RS1/16S181J
R 257 RS1/16S183J
R 258 RS1/16S183J
R 259 RS1/16S133J
R 260 RS1/16S133J
R 261 RS1/16S274J
R 262 RS1/16S274J
R 271 RS1/16S183J
R 272 RS1/8S0R0J
R 273 RS1/8S0R0J
R 275 RS1/16S473J
R 276 RS1/16S104J
R 277 RS1/16S224J
R 278 RS1/16S104J
R 281 RS1/8S0R0J
R 282 RS1/8S0R0J
R 283 RS1/8S0R0J
R 284 RS1/8S0R0J
R 285 RS1/8S0R0J
R 286 RS1/8S0R0J
R 287 RS1/8S0R0J
R 288 RS1/8S0R0J
R 292 RS1/8S0R0J
R 296 RS1/16S0R0J
R 321 RS1/8S0R0J
R 322 RS1/16S0R0J
R 351 RS1/16S102J
R 352 RS1/16S102J
R 353 RS1/16S102J
R 354 RS1/16S102J
R 355 RS1/10S274J
R 356 RS1/10S202J
R 357 RS1/10S472J
R 358 RS1/10S103J
R 359 RS1/10S103J
R 360 RS1/10S102J
R 361 RS1/10S622J
R 362 RS1/8S181J
R 373 RS1/8S0R0J

====Circuit Symbol and No.====Part Name Part No.

R 374 RS1/8S0R0J
R 375 RS1/8S0R0J
R 401 RS1/16S123J
R 402 RS1/16S332J
R 403 RS1/16S911J
R 404 RS1/16S274J

CAPACITORS

C 251 CKSRYB391K50
C 252 CKSRYB391K50
C 253 CKSRYB391K50
C 254 CKSRYB391K50
C 255 CKSRYB103K50
C 256 CKSRYB103K50
C 271 CEV1R0M50
C 272 CKSQYB104K16
C 301 CKSRYB104K16
C 302 CKSRYB104K16
C 309 CKSQYB104K16
C 310 CKSQYB104K16
C 351 CKSYB224K25
C 352 CKSQYB392K50
C 353 CKSQYB103K50
C 354 CKSQYB103K50
C 355 CKSYB104K50
C 356 CKSQYB103K50
C 401 CKSQYB472K50
C 402 CKSQYB334K16
C 403 CKSQYB223K25
C 404 CKSRYB103K50
C 405 CKSRYB333K16

O Unit Number :
Unit Name : PCB Unit

L 1 Inductor ETH0002
S 1 Switch (LOAD) ESG1004
S 2 Switch (70µs) ESG1004
EGN 1 Photo-Interrupter EGN1005

P Unit Number :
Unit Name : Reel PCB

EGN 2 Photo-Interrupter EGN1006
EGN 3 Photo-Interrupter EGN1006

Miscellaneous Parts List

C 1 CEAL4R7M35
M 1 Motor Unit (Main) EXA1499
M 2 Motor Unit (Sub) EXA1382
HD 1 Head Assy EXA1594
Pickup Unit(Service)(P8) CXX1313

6. ADJUSTMENT

6.1 TUNER, CASSETTE SECTION

● Connection Diagram

EMV Type

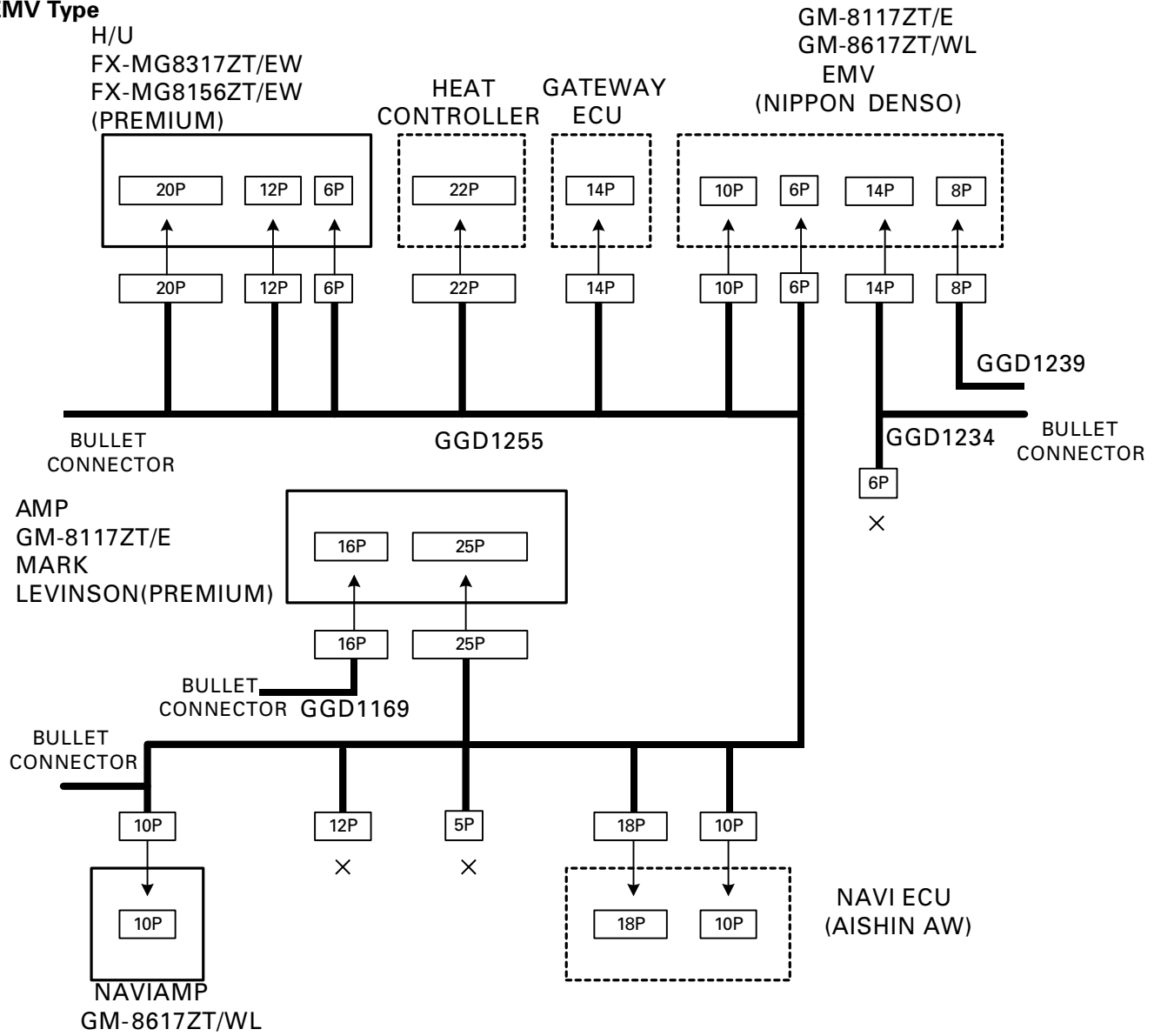

Except for EMV Type

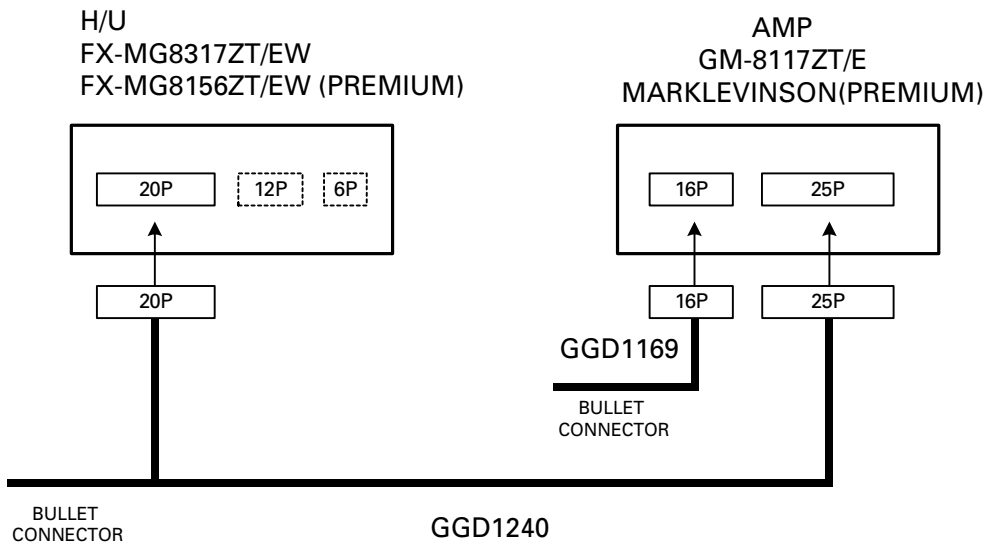

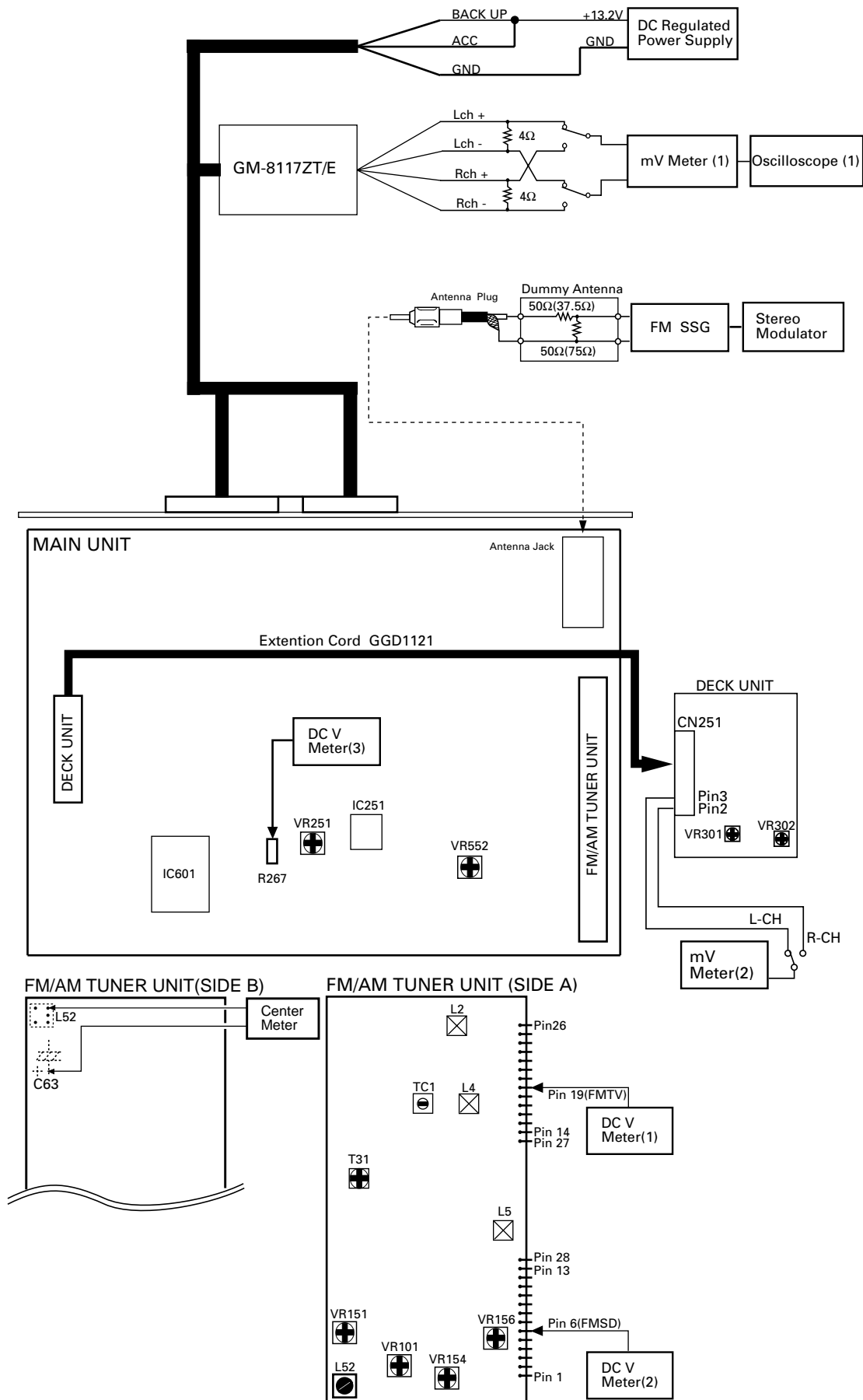

FM ADJUSTMENT

Modulation M: MONO MOD., 400Hz 30%(22.5kHz Dev.)

S1: STEREO MOD., 1kHz, L or R=30%(20.25kHz+7.5kHz Dev.)

S2: STEREO MOD., 1kHz, L or R=60%(40.5kHz+7.5kHz Dev.)

NOTE: Before proceeding to further adjustments after switching power ON, let the tuner run for ten minutes to allow the circuits to stabilize.

	No.	FM SSG		Displayed Frequency(MHz)	Adjustment Point	Adjustment Method (Switch Position)
		Frequency(MHz)	Level(dBf)			
TUN Volt	1	•••••	•••••	108.0	L5	DC V Meter(1) : 6.0V
Center Meter	1	98.1 M	65-85	98.1	L52	Center Meter : 0
IFT	1	98.1 M	5-15	98.1	T31	mV Meter(1) : Maximum
ANT Coil	1	89.9 M	5-15	89.9	L2	mV Meter(1) : Maximum
RF Coil	1	89.9 M	5-15	89.9	L4	mV Meter(1) : Maximum
RF Trimmer	1	129.3 M	60-80	107.9	TC1	mV Meter(1) : Minimum
Separation	1	98.1 S	65	98.1	VR101	mV Meter(1) : Maximum
ARC Separation	1	98.1 S	40	98.1	VR154	mV Meter(1) : Separation 5dB
Interstation	1	98.1 M	65	98.1	•••••	mV Meter(1) : AdB
Noise	2	98.1 M	-∞	98.1	VR151	mV Meter(1) : A-20dB
Search	1	98.1 M	27	98.1	VR156	DC V Meter(2) : more than 3.5V
Sensitivity	2	98.1 M	26	98.1	VR156	DC V Meter(2) : 0V
	3	Repeat steps 1 and 2 until the adjustment standards are satisfied.				

RDS SL ADJUSTMENT

	No.	FM SSG		Displayed Frequency(MHz)	Adjustment Point	Adjustment Method (Switch Position)
		Frequency(MHz)	Level(dBf)			
TUN Volt	1	104.1 S2	35	104.1	VR251	DC V Meter(3) : 1.75V+0.05V -0.35V

DOLBY NR ADJUSTMENT

No.	Test Tape	Adjustment Point	Adjustment Method (Switch Position)
1	NCT-150 (400Hz, 200nwb/m)	VR301(Lch), VR302(Rch)	mV Meter(2) : -8.24dBm(300mV)±1dB (DOLBY NR Switch : OFF)

AM NOISE CANCELER ADJUSTMENT

Connection:

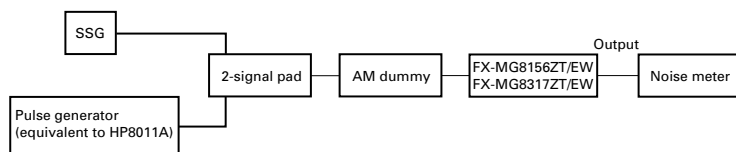

Setting of the pulse generator (setting of superimposed pulse)

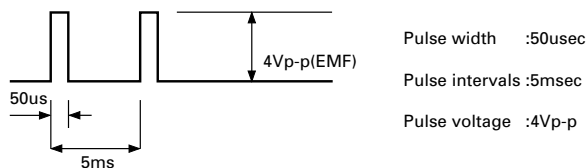

Adjustment:

1. Setting of SSG
 - Receiving frequency : 999 kHz
 - Percentage modulation : 30%
 - Modulation frequency : 400 Hz
 - Antenna input : 74 dBuV (EMF)
2. Set the system as shown in 1., then tune to a radio station.
3. Superimpose the pulse over signal to set modulation of SSG to OFF.
4. Use a noise meter to monitor output. Adjust VR552 to minimize the noise level.

6.2 CHECKING THE GRATING AFTER CHANGING THE PICKUP UNIT

• Note :

The grating angle of the PU unit cannot be adjusted after the PU unit is changed. The PU unit in the CD mechanism module is adjusted on the production line to match the CD mechanism module and is thus the best adjusted PU unit for the CD mechanism module. Changing the PU unit is thus best considered as a last resort. However, if the PU unit must be changed, the grating should be checked using the procedure below.

• Purpose :

To check that the grating is within an acceptable range when the PU unit is changed.

• Symptoms of Mal-adjustment :

If the grating is off by a large amount symptoms such as being unable to close tracking, being unable to perform track search operations, or taking a long time for track searching.

• Method :

- | | |
|-----------------------|----------------------------|
| • Measuring Equipment | • Oscilloscope, Two L.P.F. |
| • Measuring Points | • E, F, REFOUT |
| • Disc | • ABEX TCD-784 |
| • Mode | • TEST MODE |

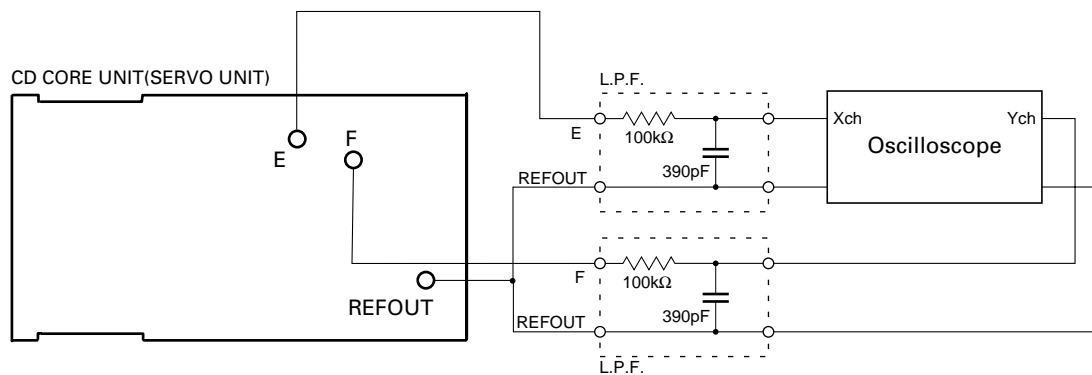

• Checking Procedure

1. In test mode, load the disc and switch the 5V regulator on.
2. Using the SEEK UP and SEEK DOWN buttons, move the PU unit to the innermost track.
3. Press key 5 to close focus, the display should read "91". Press key 3 to implement the tracking balance adjustment the display should now read "81". Press key 5 4 times. The display will change, returning to "81" on the fourth press.
4. As shown in the diagram above, monitor the LPF outputs using the oscilloscope and check that the phase difference is within 75°. Refer to the photographs supplied to determine the phase angle.
5. If the phase difference is determined to be greater than 75° try changing the PU unit to see if there is any improvement. If, after trying this a number of times, the grating angle does not become less than 75° then the mechanism should be judged to be at fault.

• Note

Because of eccentricity in the disc and a slight misalignment of the clamping center the grating waveform may be seen to "wobble" (the phase difference changes as the disc rotates). The angle specified above indicates the average angle.

• Hint

Reloading the disc changes the clamp position and may decrease the "wobble".

Grating waveform

Ech → Xch 20mV/div, AC

Fch → Ych 20mV/div, AC

0°

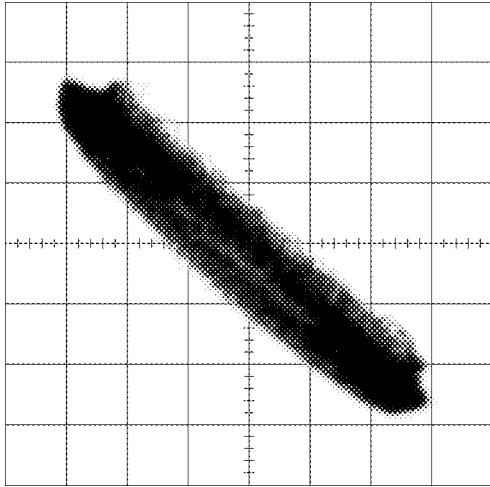

30°

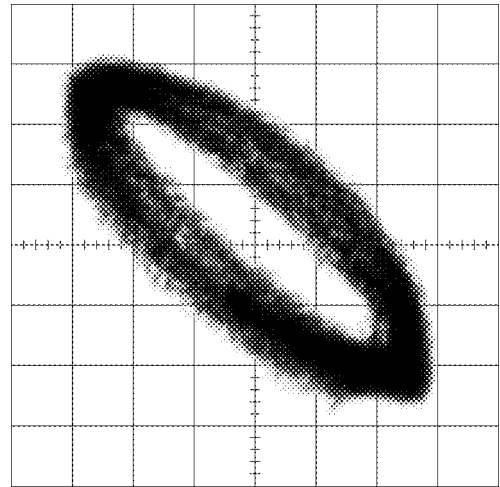

45°

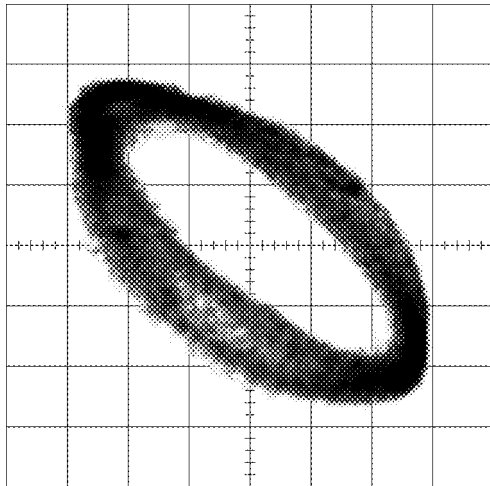

60°

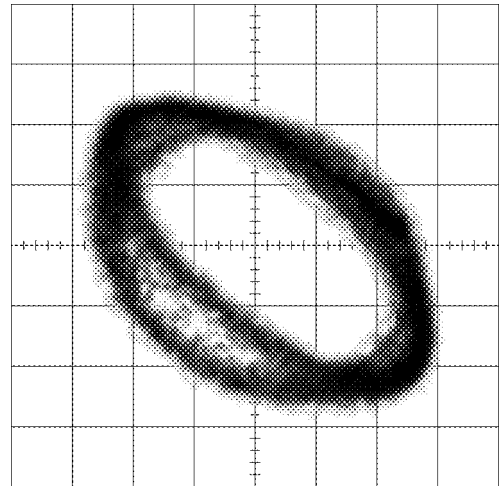

75°

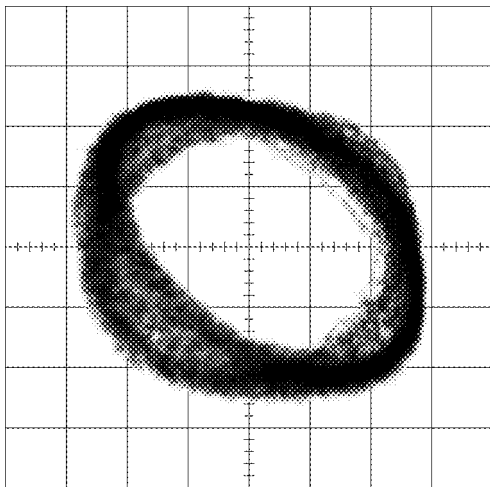

90°

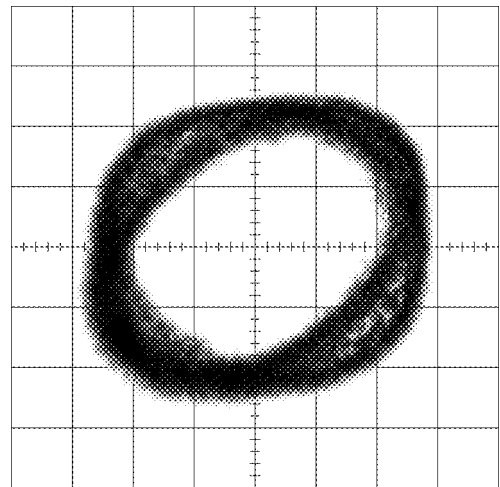

7. GENERAL INFORMATION

7.1 DIAGNOSIS

7.1.1 TEST MODE

● CD Test Mode

1) Precautions on Adjustment

- The unit employs a single voltage (+5V) for the regulator, thus the reference potential of the signal is RFOUT (approximately 2.5V) rather than GND. Inadvertent contact of RFOUT and GND during adjustment can result not only in disabling normal potential measurement but also in exposing the pickup to strong impacts due to malfunctioning of the servo. Therefore, you are requested to observe the following precautions.
- Make sure that the negative probe of the measuring instrument is not connected to RFOUT or GND. Special care must be exercised so that the channel 1 negative probe may not be connected to the oscilloscope and the channel 2 negative probe to GND. Since the frame of the measuring instrument is usually at the same potential as the negative probe, the frame of the measuring instrument must be changed to floating status. When RFOUT is inadvertently connected to GND, you must immediately turn off the regulator or power supply.
- The regulator must be turned off before mounting or dismounting filters or wiring materials.
- You should not start adjustment or measurement immediately after the regulator is turned on. It is recommended to run the player for approximately one minute so that it may stabilize.
- When the test mode is turned on, various protective functions from the software become unavailable. Thus, you must make sure that undesirable electric or mechanical shocks are not be given to the system.
- This model employs a photo-transistor for detecting discs at their loading or ejection. Thus, if its outer case is removed during repair work and internal parts are exposed to light of strong intensity, malfunctions including the following can result:
 - * The eject button becomes inoperable during play. Pressing the eject button does not eject a disc and play is continued.
 - * Loading becomes unavailable.
 If a malfunction is recognized, appropriate remedial actions must be taken. Such actions include changing the light source position, changing the unit position and applying a cover to the photo-transistor.
- When you press the EJECT key to eject a disc, you must not touch any other key until the ejection is complete.
- If you press the SEEK UP or SEEK DOWN for the focus search in the test mode, you must turn the power off immediately. (Otherwise, the lens will be forced to stick to the top or bottom, potentially resulting in the burning of the actuator.)

2) Description of the Test Mode

- Turning on the Test Mode
See page 77.
- Ending the Test Mode
Apply the reset (the reset will be applied two minutes after the power is turned from off).
- Operation of TR JUMPs (except 100TR) continues after your finger has left the key. CRG, MOVE and 100TR JUMP are forced to the tracking close mode as soon as the key is released.
- Turning the power on or off resets the JUMP MODE to the Single TR.

● How to enter the CD Test Mode

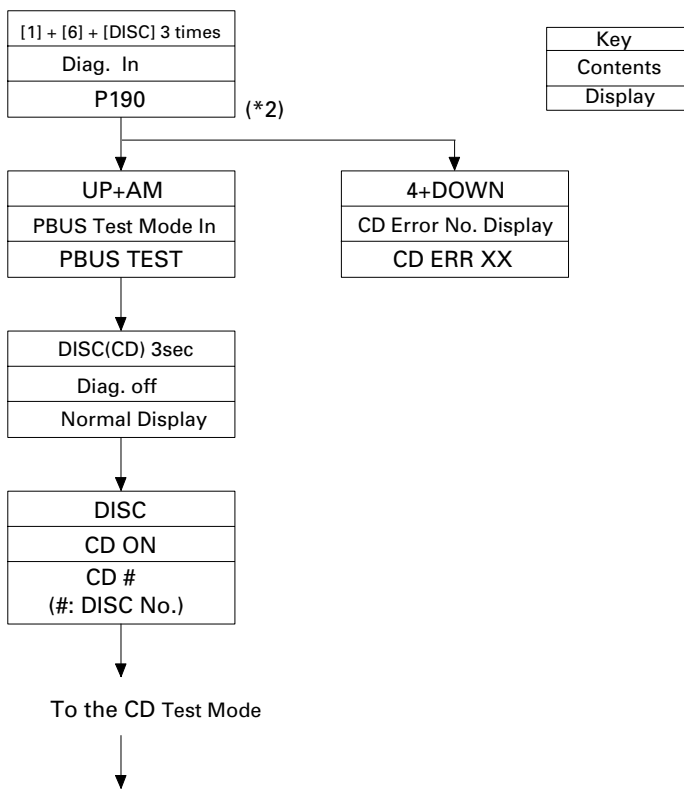

Return to the normal mode by resetting the microcomputer.(*1)

(*1) For canceling test mode, reset the unit.
(*2) No display unit connected

● CD Player Flow Chart

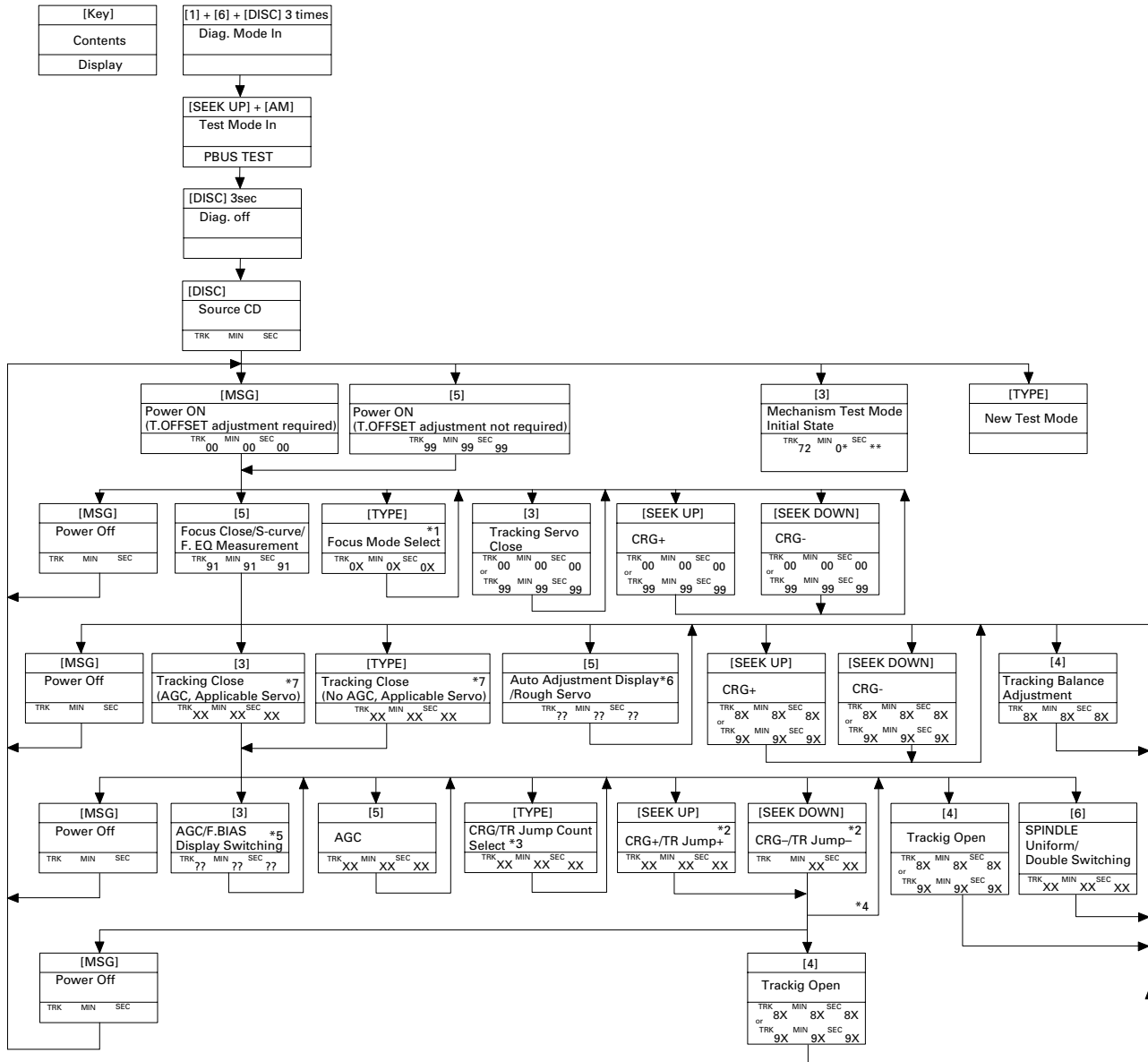

*1) Switching must take place in the following sequence.
 Focus Close → S.Curve Check → Focus EQ Measurement.
 MIN_SEC 00 00 MIN_SEC 01 01 MIN_SEC 02 02
 (MIN_SEC 99)

*2) Single TR /4TR / 10TR / 32TR / 100TR

*3) Switching must take place in the following sequence.
 Single TR → 4 TR → 10 TR → 32 TR → 100 TR → CRG Move
 9X(8X):91(81) 92(82) 93(83) 94(84) 95(85) 96(86)

*4) It applies to the CRG Move and 100TR Jump alone.

*5) Switching must take place in the following sequence.
 Min/Sec (or Track No.) → F.AGC Gain → T.AGC Gain → F. BIAS Setting
 (AGC Gain = (Current value/Initial value) x 20)

*6) Switching must take place in the following sequence.
 F.Cancel Display → T.Offset Display → T.Bal Display → Rough Servo.
 (F.Bias value, F.Cancel value, T.Offset value, T.Bal value = (Upper 8 bits of the setting (7F[H] to 80[H] + 128)/4 = 63[D] to 32[D] to 00[D]).

*7) No sound is reproduced even if Tracking Closes, because the STS IC is not controlled during the test mode.

[Key]	Operation	
	Test Mode	New Test Mode
[MSG] B0H	Power ON/OFF	Error occurrence time/Cause display selection
[SEEK UP] B1H	CRG+/TR Jump+ (Toward the outer tracks)	Track+/FF
[SEEK DOWN] B2H	CRG-/TR Jump- (Toward the inner tracks)	Track-/REV
[3] B3H	Tracking Close/AGC gain, F.Bias adjustment value display selection	—
[4] B4H	Auto Tracking Balance adjustment/ Tracking Open	Mode
[5] B5H	Focus Close, S.Curve, F.EQ measurement/ Rough Servo/AGC	—
[6] B6H	Focus Open	RANDOM
[TYPE] B8H	Focus Mode select/Tracking Close/ CRG+TR Jump selection	Auto/Manual selection
[2] A8H	DISC UP	DISC UP
[1] A9H	DISC DOWN	DISC DOWN
[EJECT] D1-D6	DISC Eject	DISC Eject
[LOAD] 61-66	DISC Load	DISC Load

Note: • If [SEEK UP] or [SEEK DOWN] key is pressed during Focus search, turn off the power immediately to prevent the actuator's damage caused by the lens stuck.
 • For all TR jumps (except for 100TR jump), the track jump operation continues even after the key is released. For the CRG Move and 100TR jump, the tracking closes at the same time when the key is released.
 • With the Power Off/On, the Jump Mode is reset to the Single TR(91).
 • To exit from the test mode, reset the unit. (All modes are completely reset about 2 minutes after the Power is turned off.)

● CD Mechanism Test Mode Flow Chart

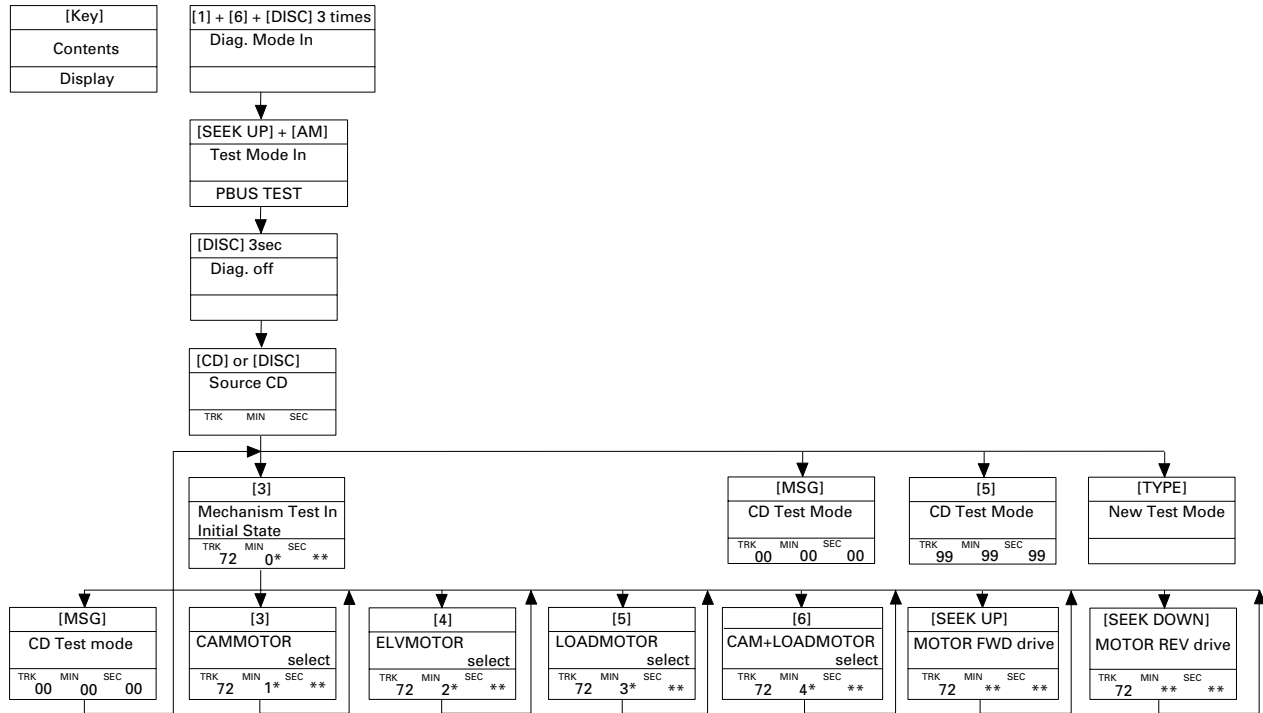

< Display in the Mechanism Test Mode >

[TRK] : 72

[MIN] : Upper (10th order): Type of motors selected
 Lower (order of 1): State of DISC sensing phototransistor and switch

- 1* : CAM motor
- 2* : ELV motor
- 3* : LOAD motor
- 4* : CAM+LOAD motors

PH1	PH2	MAXSW	Display
L	L	L	*0
H	L	L	*1
L	H	L	*2
H	H	L	*3
L	L	H	*4
H	L	H	*5
L	H	H	*6
H	H	H	*7

L: Phototransistor is OPEN and switch is ON.
 H: Phototransistor is CLOSE and switch is OFF.

[SEC] : ① When ELV motor is selected, ELV position is indicated.
 01: ELV home position (Disc 1).
 10: Each Disc position (Disc 2 to 6).
 11: Between Positions
 (The other operations except for ELV are impossible) * Note 1
 00: Not used (Abnormal condition)

② When CAM and LOAD motors selected, the state of the CAM SW (or the CAM gear) is indicated.

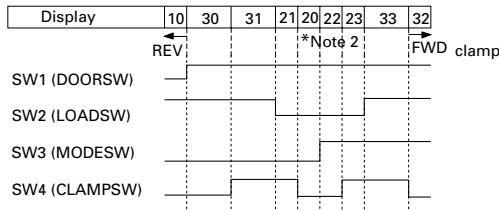

□ Operating Procedures:

- 1) Enter the DIAG mode, turn the CD TEST MODE On, exit from the DIAG mode, then switch the SOURCE to CD.
- 2) Press the [3] key to enter the MECH TEST MODE.
 TRK MIN SEC
 72* X* **
- 3) Press one of the [3] to [6] keys to select the motor to be driven.
 TRK MIN SEC
 72* X* **
- 4) When the [SEEK UP] or [SEEK DOWN] is pressed, the motor selected at Step 3) is driven.

[Key]	Operation
[MSG] B0H	To the Mech Test initial state
[SEEK UP] B1H	Drives the motor selected by [F.7] to [F.10] in the FWD direction. Operative only while the key is pressed.
[SEEK DOWN] B2H	Drives the motor selected by [F.7] to [F.10] for the REV direction. Operative only while the key is pressed.
[3] B3H	Selects the CAM MOTOR.
[4] B4H	Selects the ELV MOTOR.
[5] B5H	Selects the LOAD MOTOR.
[6] B6H	Selects the CAM + LOAD motors.
[2] A8H	DISC UP
[1] A9H	DISC DOWN
[EJECT] 43H	DISC Eject
[LOAD] 60H	DISC Load

□ Cautions

- * During the mech operation, each key input is ignored.
- * When the ELV position is '11'(*Note 1), the other motors cannot be moved.
- * For elevation, the CAMSW should be at the state *Note 2 as shown above. Basically, right after the display for the CAM SW changes from 22 to 20, drive the ELV MOTOR.)
- * When the CAM MOTOR is moved in the REV mode (31 → 30 → 10), the Elevation should be at the EJECT/LOAD position.

○ Operation steps from CLAMP to EJECT

- ① Press the [3] key to select the CAM MOTOR, and drive the CAM MOTOR from the CLAMP position (CAMSW:32) for the REV direction. The CAMSW display changes as 32→33→23→22.
- ② If the disc clamped is not the disc to be ejected, around the shifting point between 22 and 20, press the [4] key to select the ELV MOTOR and to position the elevation to the disc to be ejected. After selecting the ELV MOTOR, first be sure to move the Elevation down (in the REV direction) till the ELV position display shows 01 (Disc 1). When the Elevation is moved upward (in the FWD direction), the first indication of 10 shows the position of Disc 2, and the second indication of 10 shows that of Disc 3. Therefore, you can detect the position of the elevation by counting the number of the indication '10'.
(Ex: When the elevation moves from Disc 1 to Disc 6, the display changes as follows: 01→11→10→11→10→11→10→11→10→11→10.)
(If the disc to be ejected has been clamped, step ② is not necessary.)
- ③ Press the [3] key to select the CAM MOTOR, drive the CAM MOTOR in the REV direction till the indication changes from 20 (or 22) to the shifting point between 21 and 31.
- ④ Press the [4] key to select the ELV MOTOR, and move the tray for the disc to be ejected to the EJECT/LOAD position (in the FWD direction). (When the elevation is positioned at the top after moving in the FWD direction (the indication: 10), this is called the EJECT/LOAD position.)
- ⑤ Press the [6] key to select the CAM+LOAD MOTORS, and move the motor in the REV direction until the display changes from 31 to the shifting point between 30 and 10. When the display becomes 10, the door opens and the disc is slightly pushed out.
- ⑥ When the display becomes 10, press the [5] key to select the LOAD MOTOR. Drive the motor in the REV direction to eject the disc completely.

● **Error No. Display**

The error mode is turned on if a CD player becomes not playable or is forced to halt due to an error. Cause(s) of an error will be indicated with numerical characters. The error-number-display function is intended to facilitate the error analysis and resulting repair work.

(1) Error Code

Error code	Category	Troubles	Description/Cause(s)
10	Electricity	Carriage home error	Unable to move to or from inner perimeter → Failure on home switch or carriage move trouble.
11	Electricity	Focus search error	Unable to set a focus → Scratches or stains on backside of the disc, severe vibrations, CD-R is not written to the disc (it can happen on the backside of the disc).
12	Electricity	Spindle lock error Sub-code error	Spindle lock unavailable, sub-code unreadable → Failure on spindle, scratches on the disc, stains or strong vibrations.
14	Electricity	Mirror error	MIRR signal error continues for 500 msec or more → Stains on the disc or strong vibrations.
17	Electricity	Setup error	AGC protection cannot be turned on in time or focus can be easily lost → Scratches or stains on the disc or strong vibrations.
19	Electricity	Tracking Balance error	Tracking error level is low or tracking balance adjustment is unavailable → Failure on the pickup or tracking-error circuit.
30	Electricity	Search time-out	Target address can't be reached → Failure on the carriage/tracking or scratches on the disc.
A0	System	Error on power supply	Ground fault of power supply (VD) → Failure on switching transistor or failure of power supply.

Error code	AVC-LAN Error code
11, 12, 14, 17, 19, 30	ERROR1
10	ERROR3
A0	ERROR4

Code	Name	Description
20	Door OPENING	While the mechanism is in operation, should have been closed a door was opened.
21	Roller OFF time-out	4 seconds have elapsed before completing the roller OFF (the cam gear has not been rotated to the roller-OFF end position).
22	Roller SET time-out (Roller OFF time-out)	4 seconds have elapsed before completing the roller SET. (During the roller OFF operation, 4 seconds have elapsed while the cam gear is rotating in REV direction.)
23	Door CLOSING	Door can't be closed when the roller OFF has ended.
24	Cam started from invalid position	The cam gear attempted to do roller OFF/roller SET from an invalid position.
26	Foreign substance on photo-transistor (before closing the door)	Foreign substance was found on the photo-transistor when closing the door after the loading is complete. An error will be indicated if the disc is still caught by the photo-transistor after 4 seconds of forced eject.
29	Roller being caught	Although the cam gear has been rotated up to the roller OFF end position, the roller can't be moved to the standby position.
41	Lift DOWN time-out	4 seconds have elapsed before completing the lift DOWN operation.
42	Lift UP time-out (Lift DOWN time-out)	4 seconds have elapsed before completing the lift UP operation. (During the lift DOWN operation, 4 seconds have passed with the cam gear rotating in REV direction.)
45	Lift DOWN cam displacement	The lift DOWN complete cam gear has been displaced from its specified position.
52	EJECT time-out	8 seconds have elapsed before completing the EJECT operation. An error will be indicated if the disc is still caught by the photo-transistor after 4 seconds of forced eject.
57	Photo-transistor being caught after forced EJECT	When forced eject was employed for the Bup failure during loading or ejection, an error will be indicated if the disk is still caught by the photo-transistor after 4 seconds of forced eject.
61	CRGIN time-out (CRGOUT time-out)	10 seconds have elapsed before completing CRGIN operation. (During CRGOUT operation, 10 seconds have elapsed with the cam gear rotating in REV direction.)
62	CRGOUT time-out	10 seconds have elapsed before completing the CRGOUT operation.
65	CRGOUT cam displacement	Position of the CRGOUT complete cam gear has been displaced.
71	ELVUP time-out	2 seconds have elapsed before completing 1-stage UP.
72	ELVDN time-out	2 seconds have elapsed before completing 1-stage DOWN.
74	ELV displacement	At the start of ELV, ELVSNS was not set to low. (In case of starting from the 1st floor, ELHOME was not set to low.)
75	ELV counting error	HLHOME was set to low though not on the 1st floor. (There is a conflict between the floor number stored on the microcomputer and the actual floor number.)
91	LOAD time-out	8 seconds have elapsed before completing the LOAD. An error will be indicated if the disc is still caught by the photo-transistor after 4 seconds of forced eject.
96	Settlement of foreign substance	Unauthorized foreign substance such as 8 cm disc has been loaded. An error will be indicated if the disc is still caught by the photo-transistor after 4 seconds of forced eject.

* AVC-LAN Error code : ERROR3

7.1.2 DISASSEMBLY

● **Removing the Case (Fig.1)**

➔ **1** Remove the four screws and then remove the Case.

● **Removing the Grille Assy (Fig.1)**

➔ **2** Remove the two screws.

Disconnect the connector and then remove the Grille Assy.

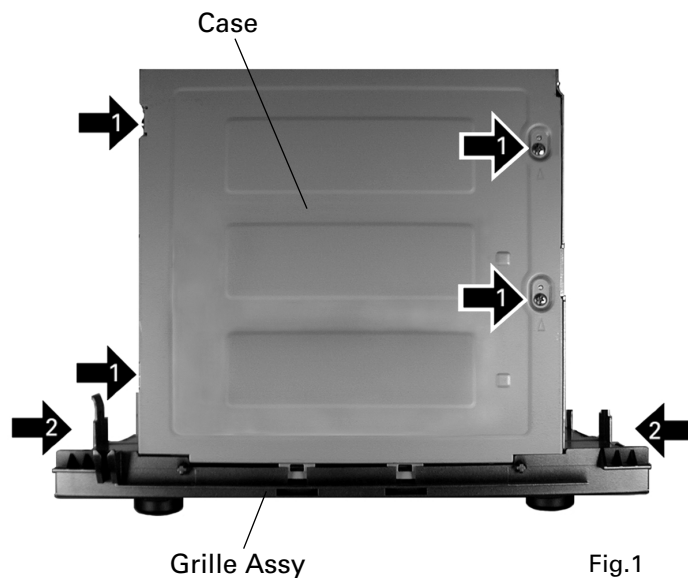

● **Removing the Chassis (Fig.2)**

➔ **1** Remove the eleven screws and then remove the Chassis.

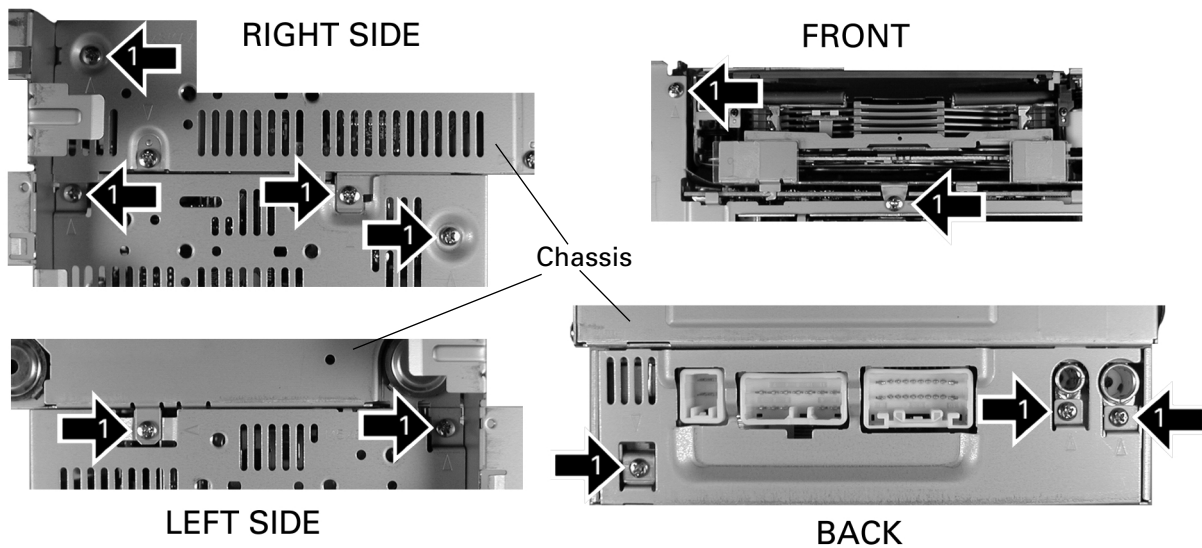

● **Removing the Cassette Mechanism Module (Fig.3)**

- ➔ 1 Remove the four screws and then remove the Cassette Mechanism Module.

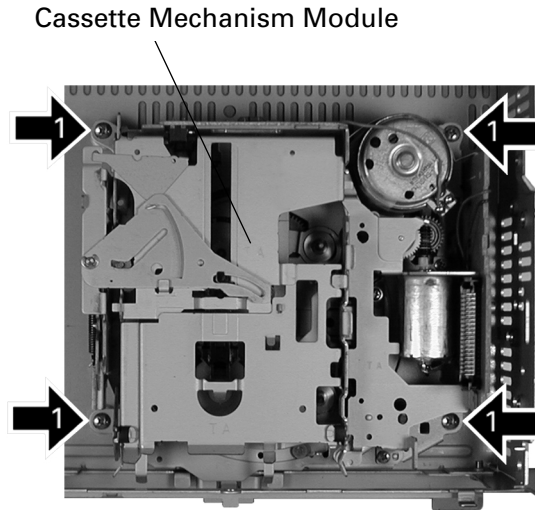

Fig.3

● **Removing the Control Unit (Fig.4)**

1. Unbend the tabs at two locations indicated by arrows until straight.
2. Remove the screw F.
3. Disconnect the two connectors, and then remove the Control Unit.

● **Removing the Mechanism Unit (Fig.4)**

1. Remove the five screws G, and then remove the four Holders and four Dampers.
2. Remove the two springs A, spring B, spring C, and four tubes from the hock.
3. Remove the Mechanism Unit from the Chassis.

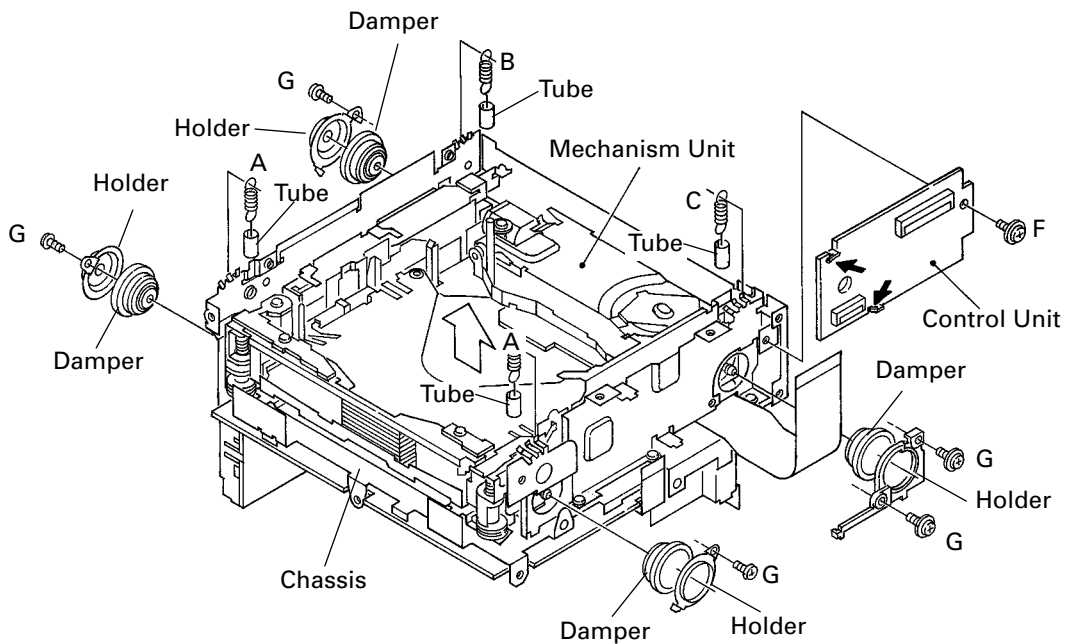

Fig.4

● **Removing the Main Unit (Fig.5)**

- ➔ **1** Straight the tabs at four locations indicated.
- ➔ **2** Remove the screw and then remove the Main Unit.

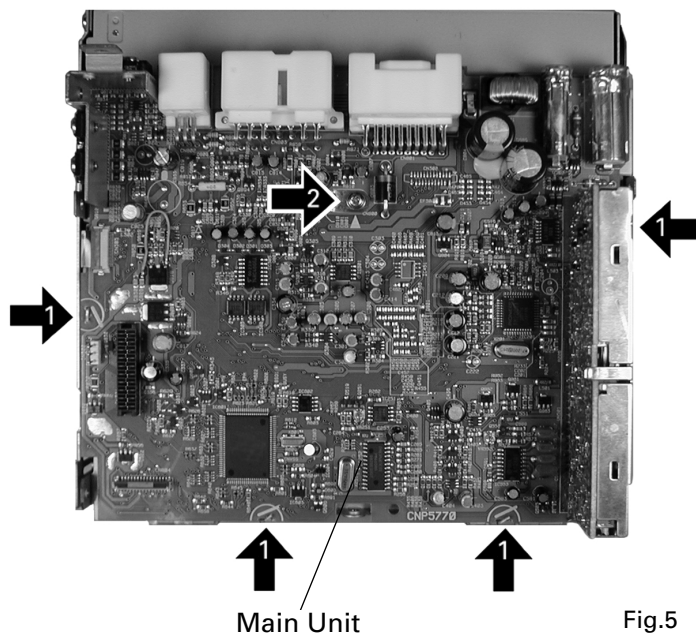

Fig.5

● **How to remove the Tray Assy**

1. Apply about 6V current to the Cam gear motor until all holes match at the position (A) (elevation OK position).
 2. Hook the three springs B temporarily as shown in Fig. 6. While pushing the Tray holder lock arms (right and left) in the direction (C), remove the Tray holder.
 3. Lift up the Tray assy to remove it.
- * Be careful not to remove the Tray hooks from the Tray assy.

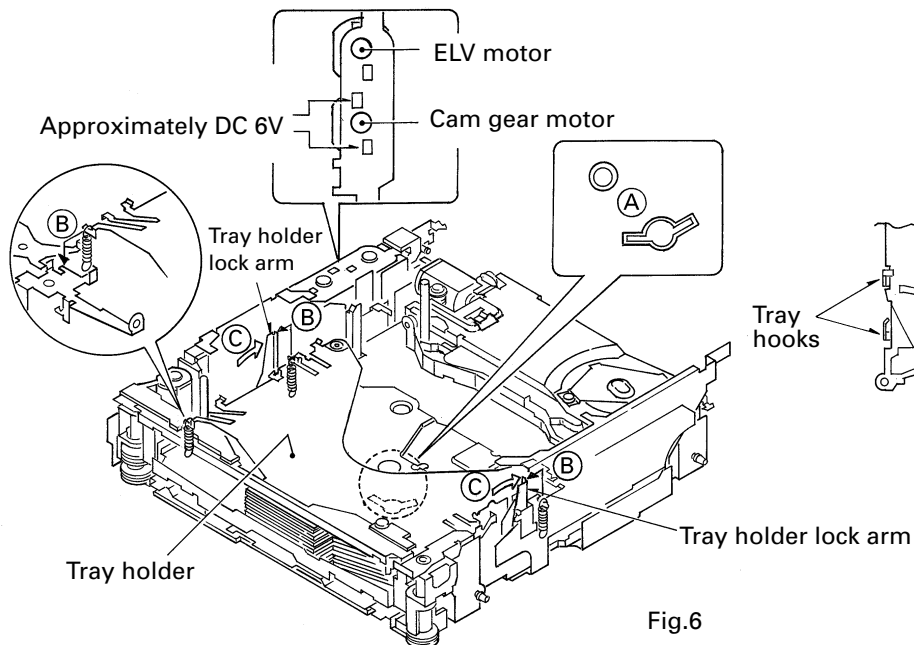

Fig.6

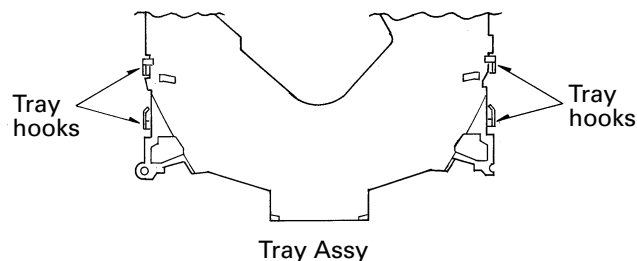

Fig. 7

● **How to remove the Carriage Mech Assy**

1. Insert a short pin into the flexible PCB of the Pickup unit.
2. While opening the resin hooks, remove the cover from the Servo unit.
3. Disconnect the flexible PCBs from the connectors CN101 and CN301.
4. Remove the Tray holder and the Tray assy. (See above)
5. Rotate the Cam gear motor until the positions of all holes (E) match, then stop the motor.
(The Carriage Mech assy will stop as shown in the Fig.8.)

- * When the positions of all holes match, they will be completely covered by the Carriage mech assy.
 - * To rotate the Cam Gear motor, see "How to remove the Tray assy".
6. Unhook the spring A.
 7. Remove the flexible holder B (while opening the hooks).
 8. Remove the flexible PCB (C) from the motor. (The flexible PCB (C) has been stuck on the motor with double-sided adhesive tape.)
 9. Loosen the fixing screw and remove the flexible holder.

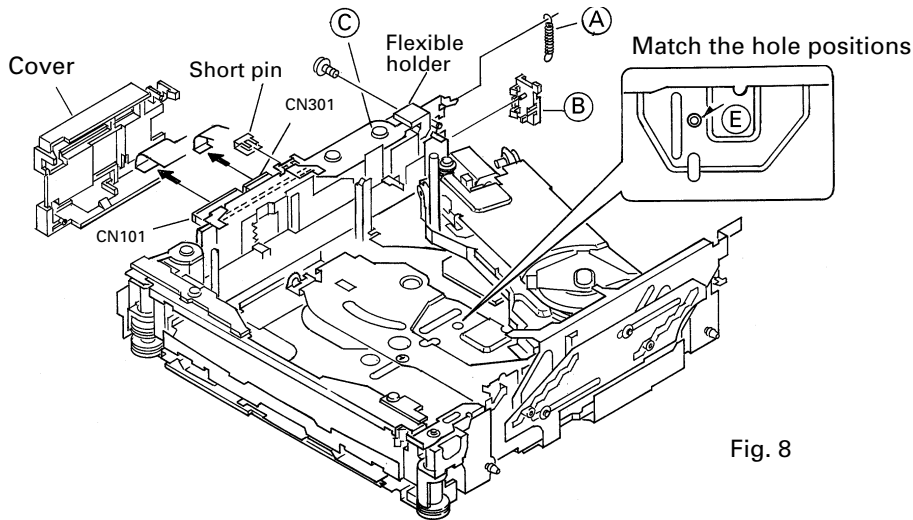

Fig. 8

10. Remove the screw, pressure spring and collar. Lift up the Carriage mechanism assy to remove it.
* Screw tightening torque: 2.6kgfcm

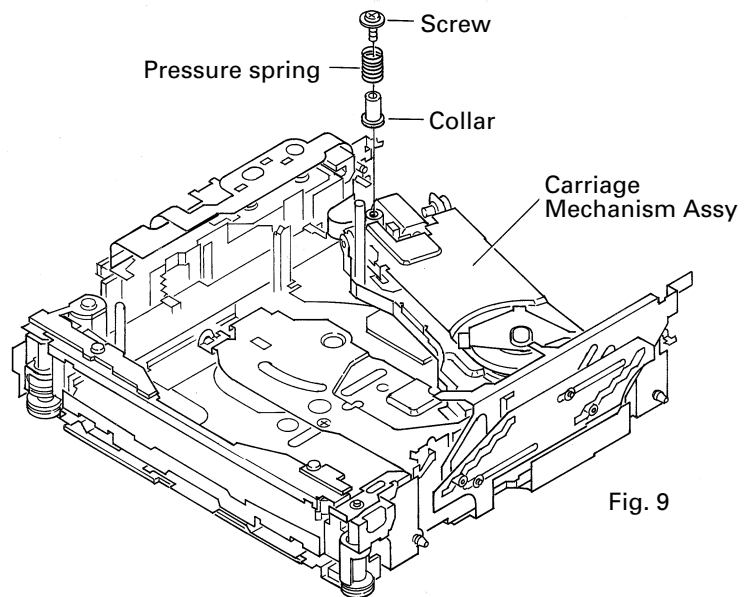

Fig. 9

● **How to remove the Pickup unit**

1. Remove the pulling spring, torsion spring and E-shaped ring. Then remove the Clamper arm.
- * The spring (A) will be removed with the Clamper arm.

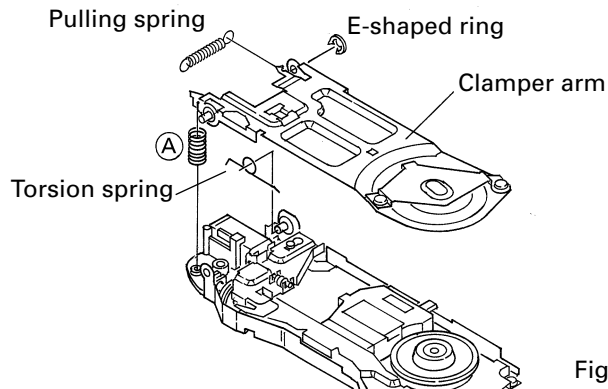

Fig. 10

2. Slide the Clamp UP lever (B) to remove it.
3. Loosen the 2 screws. Remove the feed-screw cover by sliding it.
4. Remove the feed-screw pressure spring (D).
5. Loosen the 2 screws. Remove the feed-screw holder (E).
6. Remove the belt.

7. Remove the Pickup unit together with the feed screw.
- * Be careful not to lose the shaft holders at the both ends of the feed screw.
- * Be careful not to damage the 2 flexible PCBs (for the Pickup and motor) when separating them. The flexible PCBs have been stuck each other with double-sided adhesive tape.

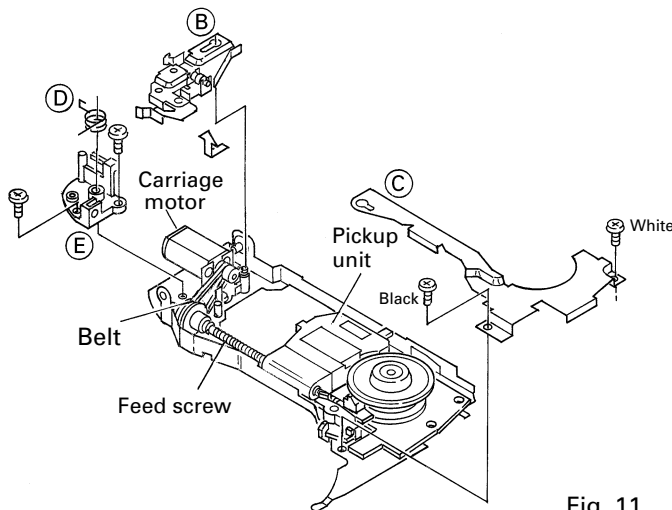

Fig. 11

8. Loosen the 2 screws. Remove the plate spring and the rack.
9. Pull out the feed screw from the Pickup unit.

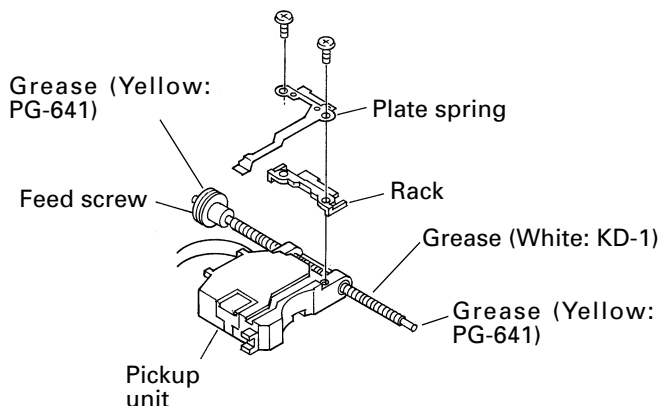
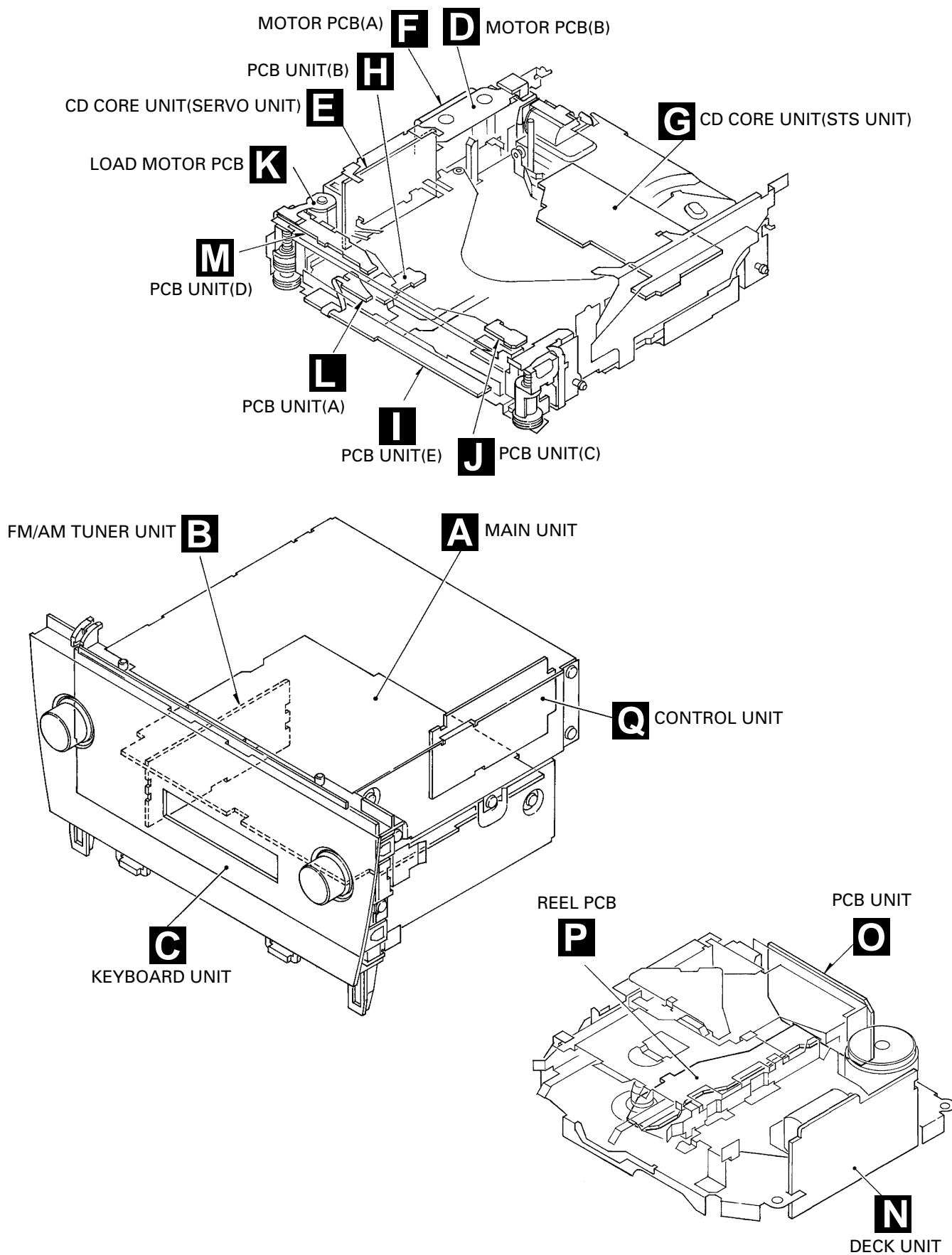
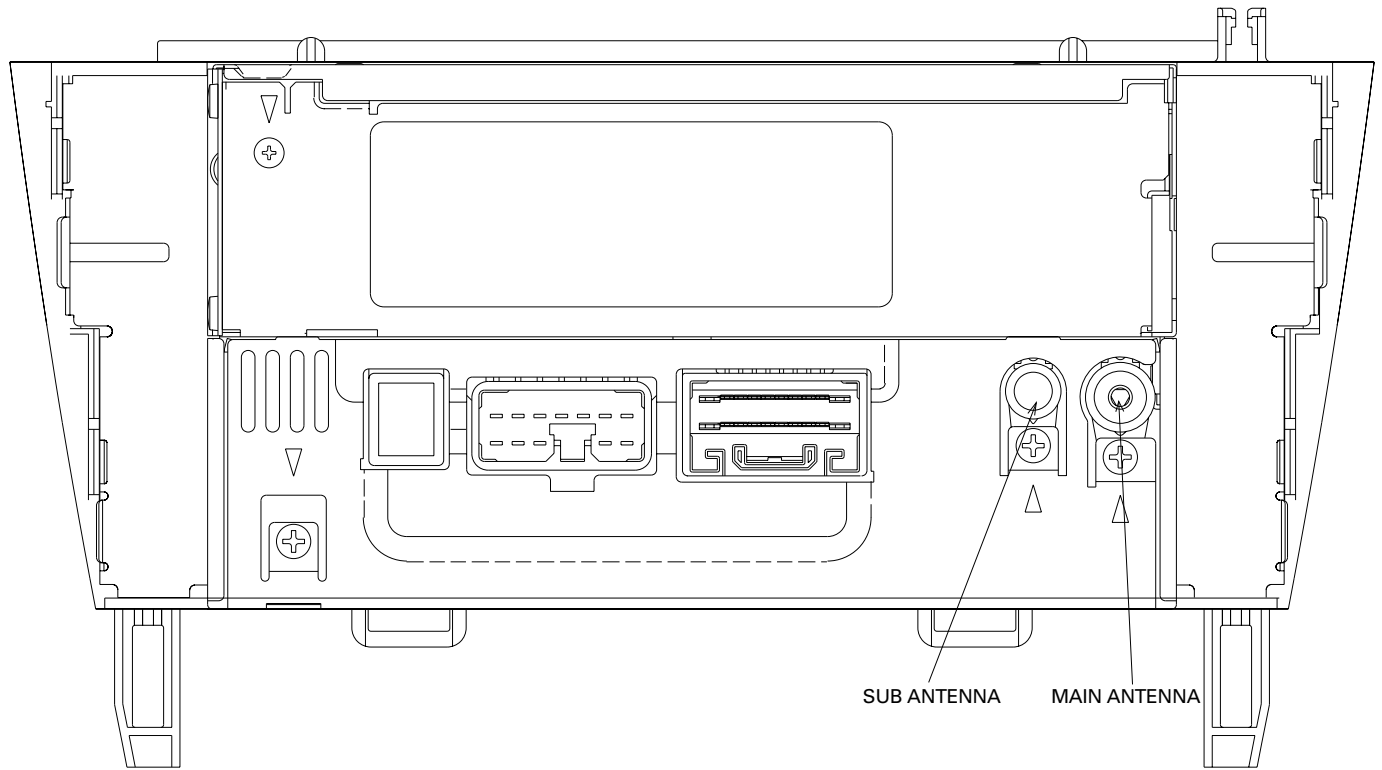

Fig. 12

7.1.3 PCB LOCATIONS



7.1.4 CONNECTOR FUNCTION DESCRIPTION



ANTB		TXS+
ANTA	DOS1	TXS+

R-	L-	GND	TXM-	TXM+		ACC
R+	L+	SGND			MUTE	+B

ACC	ILL-	ANT		TX-		R-	L-	GND	
+B	ILL+			TX+		MUTE	R+	L+	SGND

7.2 PARTS

7.2.1 IC

● Pin Functions (PD5567A)

Pin No.	Pin Name	I/O	Function and Operation
1	SL	I	SD level input from tuner
2	MDSN	I	Modulation level input
3	RDSLK	I	RDS LK signal input
4	LAMP	O	Lamp power supply control output
5	LDO	O	LCD driver data output
6	LDI	I	LCD driver data input
7	LCK	O	Clock output for LCD driver
8	BYTE	I	Connect to VSS
9	CNVSS	I	Connect to VSS
10,11	NC		Not used
12	RESET	I	Reset input
13	XOUT	O	Crystal oscillating element connection pin
14	VSS		GND
15	XIN	I	Crystal oscillating element connection pin
16	VDD		Power supply terminal
17	NMI		Not used
18	RCK	I	RDS clock input
19	LDET	I	PLL lock sense input
20	CDEJ	I	CD eject key sense input
21	RX2	I	IE-BUS data input
22	IPPW	O	IP-BUS driver power supply output
23	ILSENS	I	Illumination sense input
24	DRST	O	RDS decoder reset output
25	57K	I	57kHzBP-OUT sense input
26	CURRO	O	Tuner voltage FIX output
27	SK	I	SK signal input
28	BLIGHT	O	Back light power supply ON/OFF output
29	RX1	I	IE-BUS data input
30	TX	O	IE BUS data output
31	PDO	O	Data output for PLL IC
32	PDI	I	Data input from PLL IC
33	PCK	O	Serial clock output for PLL IC
34	PCE	O	Chip enable output for PLL IC
35	BSO	O	P-BUS serial data output
36	BSI	I	P-BUS serial data input
37	BCK	O	P-BUS serial clock output
38	BRXEN	I/O	P-BUS reception enable input/output pin
39	BRST	I	P-BUS reset input
40	BSRO	O	P-BUS service request output pin
41	ANTPW	O	Antenna power supply control output
42	RDT	I	RDS demodulation data input
43	FMPW	O	FM power supply control output
44	AMPW	O	AM power supply control output
45	SWVDD	O	Keyboard unit power supply control output
46	MW	O	MW/LW select output (not used)
47	SFIX	O	Sub antenna fix output
48	ANSW	O	Analog switch control output
49	CDILL	O	CD illumination output
50	TAPMUTE	O	TAPE mute output
51	MUTE	O	BUS mute output
52	SYSPW	O	System power control output
53	SYSMUTE	O	System mute output
54	POWER	I	POWER key input
55	ENC1+	I	VOL encoder (+) input
56	ENC1-	I	VOL encoder (-) input
57	MODE	I	AUDIO mode key input
58	ENC2+	I	AUD encoder (+) input

Pin No.	Pin Name	I/O	Function and Operation
59	ENC2-	I	AUD encoder (-) input
60	DLOAD	I	CDM load key input
61	ILL	O	LAMP power supply control output
62	VCC		Power supply terminal
63	RECIVE	O	During RDS data reception output
64	VSS		GND
65	RDSMT	O	RDS mute output
66	AMMUTE	O	AM mute output
67	FMMUTE	O	FM mute output
68	DOS	I	Door switch input
69	MS	I	Music sense input
70	FR	O	Cassette mechanism head forward/reverse select output
71	PLAY	O	MS gain select output
72	MTL	I	Cassette mechanism tape select input
73	ASENS	I	ACC power sense input
74	CSEJ	I	Tape eject sense input
75	BSENS	I	Back up power sense input
76	NR	O	Dolby NR ON/OFF select output
77	CSLOAD	I	Tape loading detect input
78	POS	I	Cassette mechanism position sense input
79	RES	I	Cassette mechanism reverse end sense input
80	NES	I	Cassette mechanism forward end sense input
81	TEST	I	Test mode input
82	SC2	O	Cassette mechanism sub motor control 2 output
83	SC1	O	Cassette mechanism sub motor control 1 output
84	CM	O	Cassette mechanism capstan motor control output
85	STBY	O	Cassette mechanism driver stand-by output
86	LRST	I	LCD driver reset output
87	LCE1	O	Chip enable output pin for LCD driver 1
88	LCE2	O	Chip enable output pin for LCD driver 2
89	ST	I	FM stereo input
90	FMSD	I	FM SD input
91	NL	I	Noise level input
92	CL	I	RDS tune off sense input
93	RDSL		RDS signal level
94	ANT0	O	Antenna control A output
95	NC		Not used
96	AVSS	I	A/D converter GND
97	ANT1	O	Antenna control B output
98	VREF	I	A/D converter reference voltage input
99	AVCC		A/D converter power supply
100	LOFF	O	LCD driver inhibit output

*PD5567A

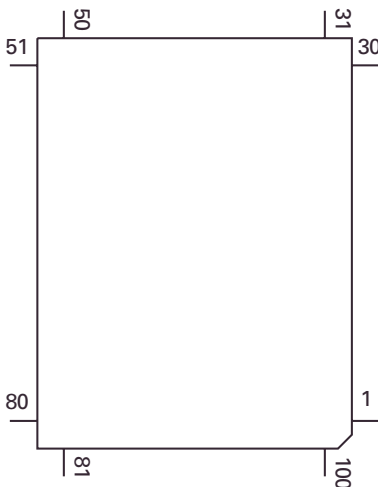

IC's marked by* are MOS type.

Be careful in handling them because they are very liable to be damaged by electrostatic induction.

Format	Meaning
C	C MOS

● Pin Functions (PD5673A)

Pin No.	Pin Name	I/O	Format	Function and Operation
1	VDIN	I		Power supply short sensor input
2	DOORSW	I		Door open position SW input
3	NC			Not used
4	BSRQ	O	C	P-BUS service request output
5	CLAMP	I		DISC clamp SW input
6	ELHOME	I		ELV reset position SW input
7	XSCK	O	C	CD LSI clock output
8	XSO	O	C	CD LSI data output
9	XSI	I		CD LSI data input
10	XSTB	O	C	CD LSI strobe output
11	XRST	O	C	CD LSI reset output
12	XA0	O	C	Control signal distinguishing data from microcomputer
13	VDCONT	O	C	VD control output
14	NC			Not used
15	BSENS	I		Back up power sense input
16	BRXEN	I/O	C	P-BUS reception enable input/output
17	LOADSW	I		Loading position SW input
18	MODESW	I		ELV OK position SW input
19	BSCK	I/O	C	P-BUS serial clock input/output
20	BSO	O	C	P-BUS serial data output
21	BSI	I		P-BUS serial data input
22	BRST	I		P-BUS reset input
23	SBSY	I		Signal indicating head of subcode block
24	CNVSS	I		GND
25	RESET	I		Reset input
26	POWER	O	C	Servo/Mechanism power supply control output
27	CONT	O	C	Servo driver output control
28	Xin	I		Crystal oscillating element connection pin
29	Xout	O	C	Crystal oscillating element connection pin
30	VSS			GND
31-38	NC			Not used
39	TESTIN	I		Chip check program mode input
40	DCLOSE	I		Door close sense input
41	WDSL	O	C	Data comparison area specification signal output
42	XWIH	I		Data write inhibit input
43	XEMP	I		Data read inhibit input
44	CHDT	I		Data comparison mode monitor input
45	CHM0	O	C	Data comparison mode output 0
46	CHM1	O	C	Data comparison mode output 1
47-49	NC			Not used
50	XWRE	O	C	DRAM WRT ENBL
51	XRDE	O	C	DRAM READ ENBL
52	XQOK	O	C	SUB-Q OK output
53	EMPH	O	C	DAC emphasis output
54	SCONT	O	C	Mode select output
55	LOAD	O	C	PHOT power supply control
56	CDMUTE	O	C	CD mute output
57	LO2	O	C	LOAD motor control terminal output 2
58	LO1	O	C	LOAD motor control terminal output 1
59	ELV2	O	C	ELV motor control terminal output 2
60	ELV1	O	C	ELV motor control terminal output 1
61	CG2	O	C	CAM motor control terminal output 2
62	CG1	O	C	CAM motor control terminal output 1
63	MIRR	I		CD LSI mirror detector input
64	LOCK	I		CD LSI spindle lock detector input
65	FOK	I		CD LSI FOK signal input
66-68	NC			Not used
69	ADENA	O	C	A/D reference voltage output

Pin No.	Pin Name	I/O	Format	Function and Operation
70	NC			Not used
71	VCC			VDD
72	VREF	I		A/D converter reference voltage input
73	AVSS			A/D GND
74	ADRMON	I		The remainder amount address monitor input
75	EREF			DRAM A/D reference voltage output
76	PH1	I		Disc photo sense input 1
77	PH2	I		Disc photo sense input 2
78	PH3	I		Disc photo sense input 3
79	ELVSNS	I		ELV position photo sense input
80	TEMP	I		Temperature detector input

*PD5673A

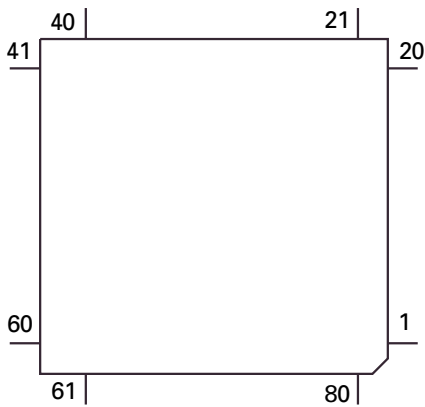

Format	Meaning
C	C MOS

*LC75804W

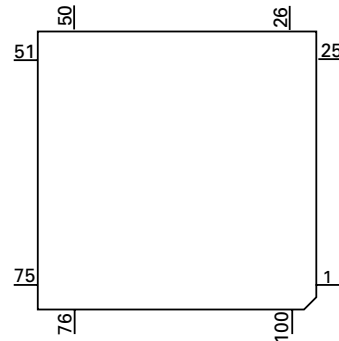

● Pin Functions (LC75804W)

Pin No.	Pin Name	I/O	Function and Operation
1-73	SEG01-73	O	LCD segment signal output
74-77	COM4-1	O	LCD common signal output
78,79	SEG75,76		Not used
80-83	KS3-6		Not used
84-88	KI1-5	I	Key scan input
89	VDD		Power supply
90	VLCD		Power supply for LCD driver
91	VLCD1	I	LCD drive bias impressed voltage (2/3) input
92	VLCD2	I	LCD drive bias impressed voltage (1/3) input
93	VSS		GND
94	TEST		GND
95	OSC	I/O	Oscillator terminal
96	RES	I	Reset signal input
97	DO		Not used
98	CE	I	Chip enable input
99	CL	I	Synchronizing clock input
100	DI	I	Transfer data input

7.2.2 DISPLAY

● CAW1691

SEGMENT

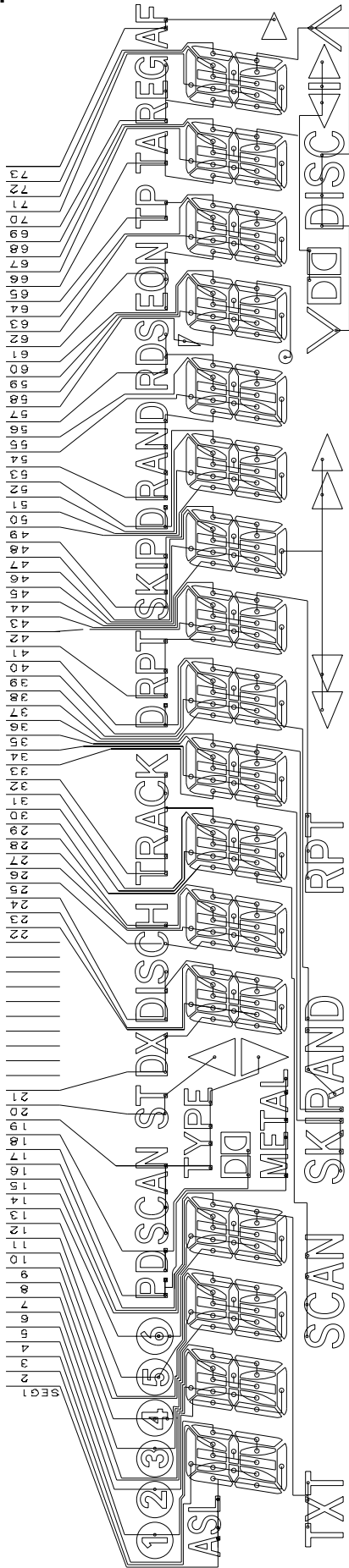

COMMON

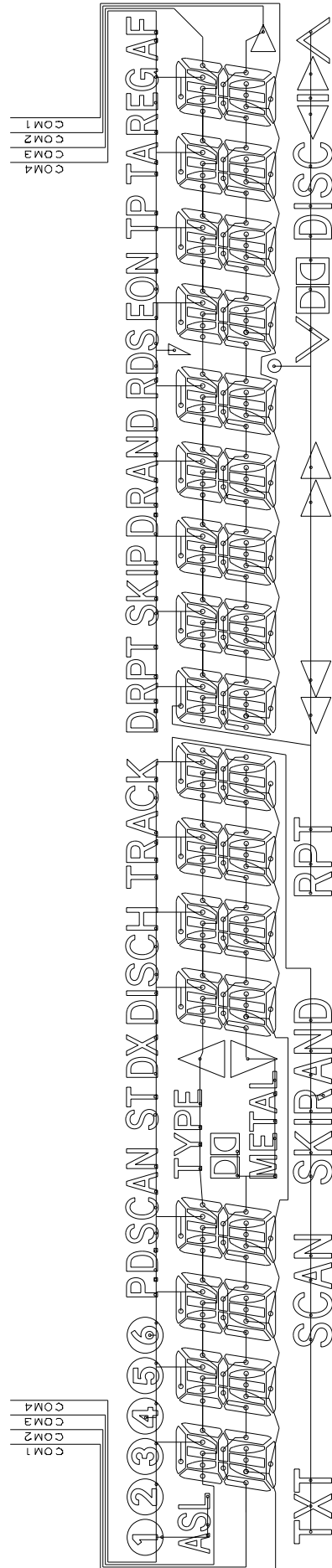

7.3 EXPLANATION

7.3.1 SYSTEM BLOCK DIAGRAM

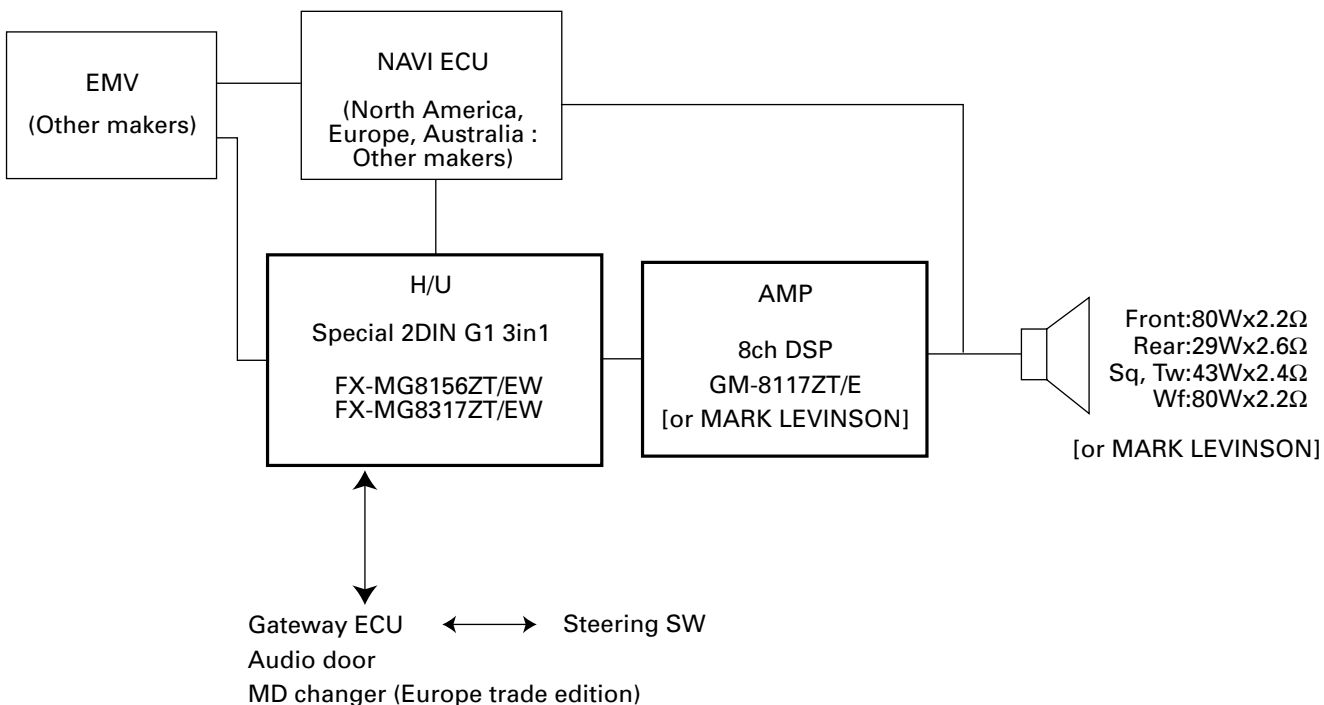

- EMV, NAVI, and TV TU depends on the model.
- MD changers are available for the European models.(Dealer options)
- Amplifier has the sound exchange function between left and right when received BUS information from the gateway.

Product combination

Destination	H/U	Amplifier
Europe	FX-MG8317ZT/EW	GM-8117ZT/E
Europe MARK LEVINSON	FX-MG8156ZT/EW	MARK LEVINSON

7.3.2 OPERATIONAL FLOW CHART

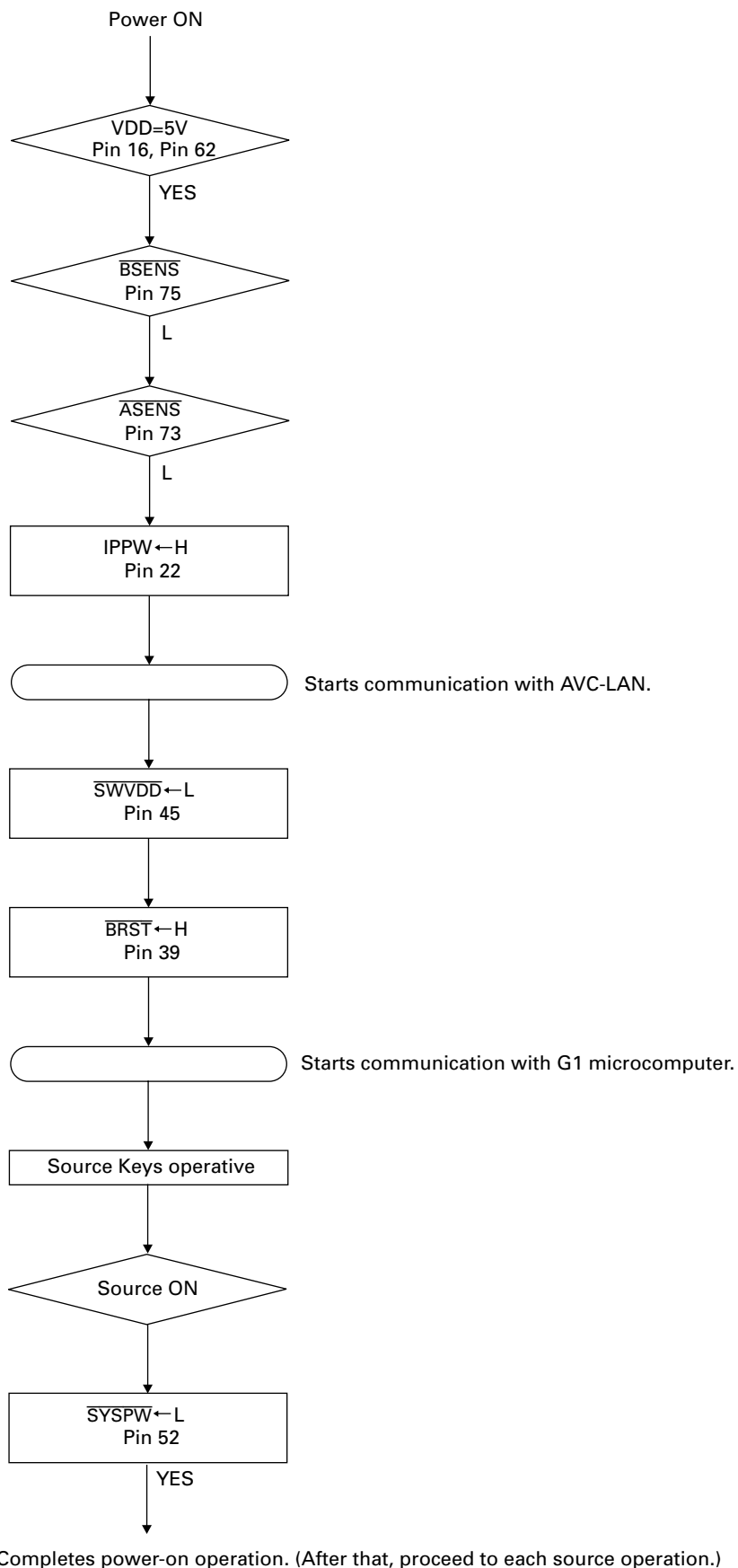

8. OPERATIONS AND SPECIFICATIONS

8.1 OPERATIONS

● RADIO

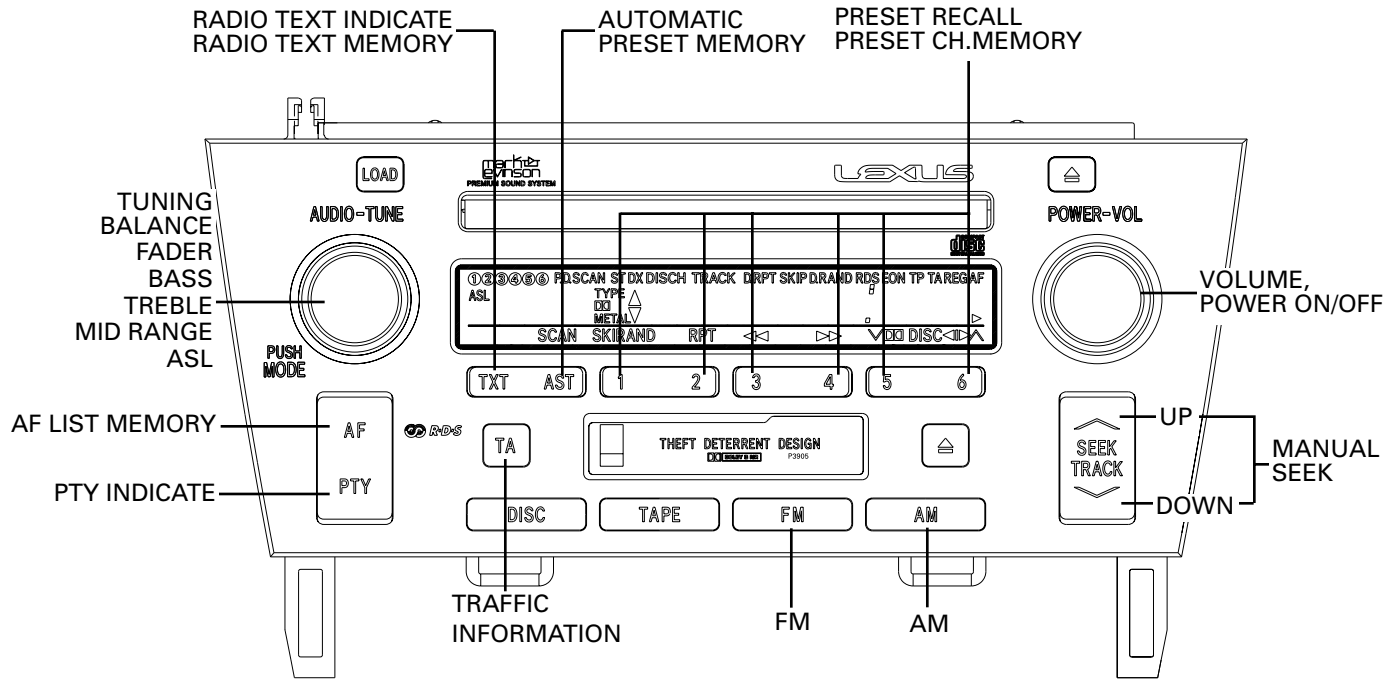

● TAPE

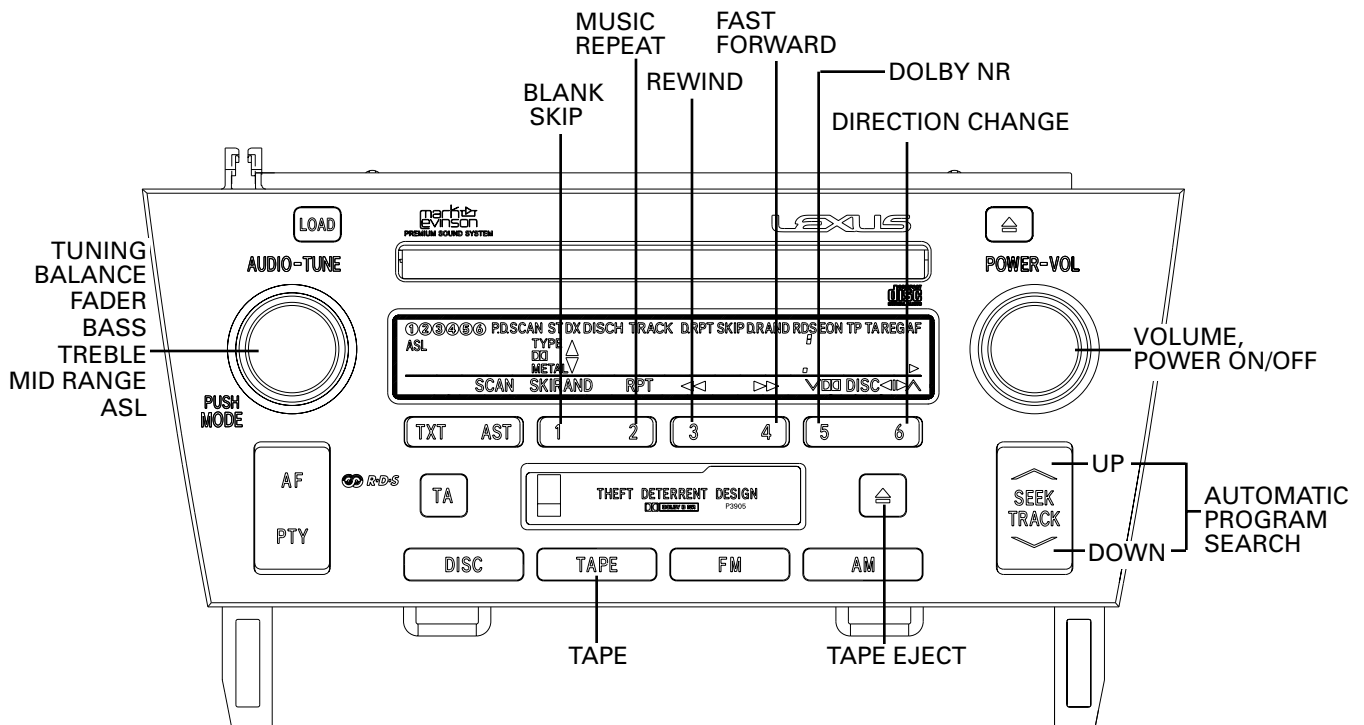

● CD

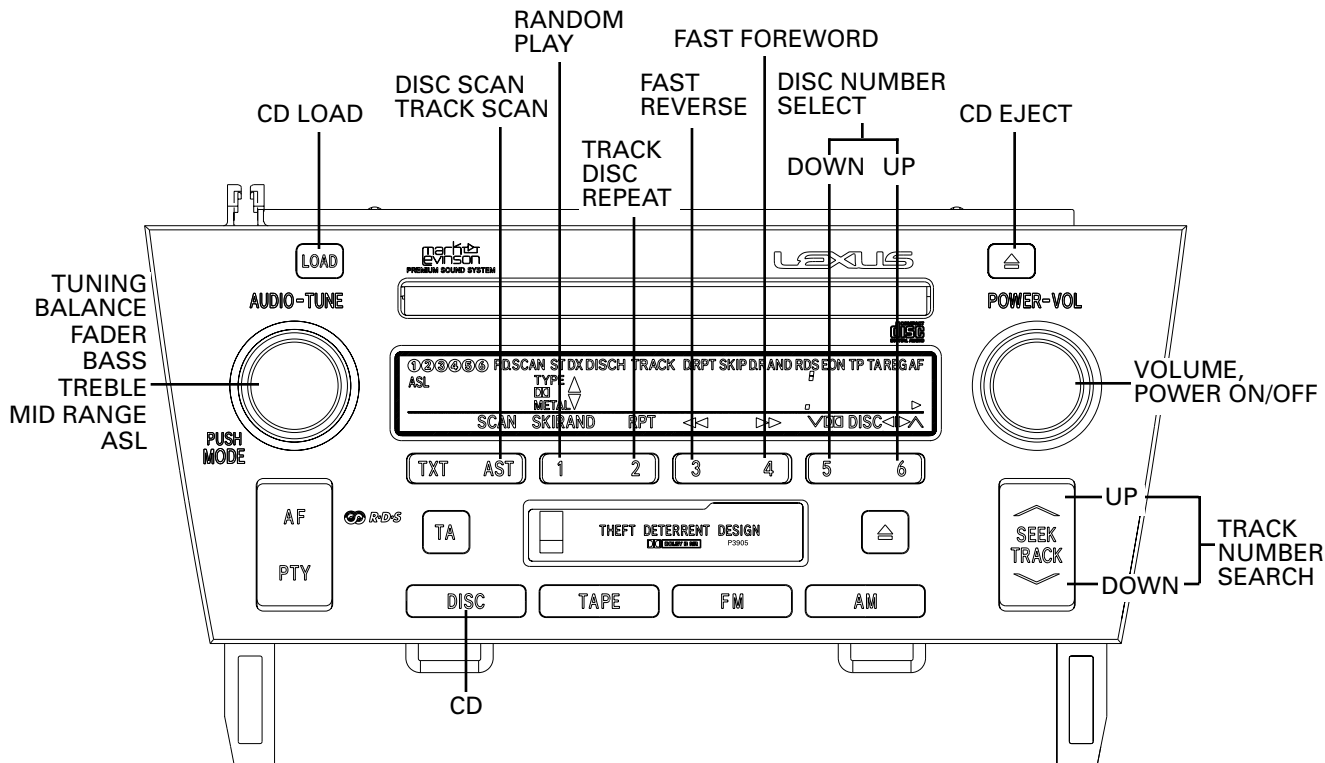

8.2 SPECIFICATIONS

Power source.....13.2V(10.5V-16.0V allowable) DC
 Backup current.....1.2mA or less
 Grounding system.....Negative type
 Dimensions(Chassis).....178(W)x100(H)x160(D)mm
 (Grille).....251(W)x101(H)x20(D)mm
 Weight.....2.6kg

Cassette player

Tape.....Compact cassette tape(C30-C90)
 Tape speed.....4.76 cm/sec.(+0.14 cm/sec.,-0.05 cm/sec.)
 Wow and flutter.....0.2% or less(WRMS)
 Crosstalk.....40dB or less
 Stereo Separation.....30dB or more
 S/N.....41dB or more
 Distortion.....3% or less

CD player

System.....Compact disc audio system
 Usable discs.....Compact disc
 Signal format.....Sampling frequency : 44.1kHz
Number of quantization : 16;linear
 S/N.....70dB or more
 Distortion.....0.2% or less

FM tuner

Frequency.....87.5-108.0 MHz
 S/N.....50dB or more
 Distortion.....1.5% or less
 IF interference.....89dB or more
 Image interference.....55dB or more
 Stereo Separation.....25dB or more(1kHz)

MM tuner

Frequency.....531-1602 kHz
 Selectivity.....50dB or more(±9kHz)
 S/N.....44dB or more
 Distortion.....1.0% or less
 IF interference.....60dB or more
 Image interference.....50dB or more

LM tuner

Frequency.....153-279 kHz
 Selectivity.....50dB or more(±10kHz)
 S/N.....40dB or more
 Distortion.....1.5% or less
 IF interference.....60dB or more
 Image interference.....50dB or more

PIONEER CORPORATION

4-1, Meguro 1-Chome, Meguro-ku, Tokyo 153-8654, Japan

PIONEER ELECTRONICS SERVICE INC. P.O.Box 1760, Long Beach, CA 90801-1760 U.S.A.

PIONEER EUROPE NV Haven 1087 Keetberglaan 1, 9120 Melsele, Belgium

PIONEER ELECTRONICS ASIACENTRE PTE.LTD. 253 Alexandra Road, #04-01, Singapore 159936