

Service Manual

Pioneer
TOYOTA

ORDER NO.
CRT2584

LEXUS SC430 **AUDIO SYSTEM** **HEAD UNIT**

VEHICLE	DESTINATION	PRODUCED AFTER	TOYOTA PART No.	ID No.	PIONEER MODEL No.
LEXUS SC430	U.S.A., CANADA	January 2001	86120-24390	P6813	FX-MG8217ZT/UC
LEXUS SC430	U.S.A., CANADA	January 2001	86120-24390	P6813	FX-MG8217ZT-91/UC

FX-MG8217ZT/UC

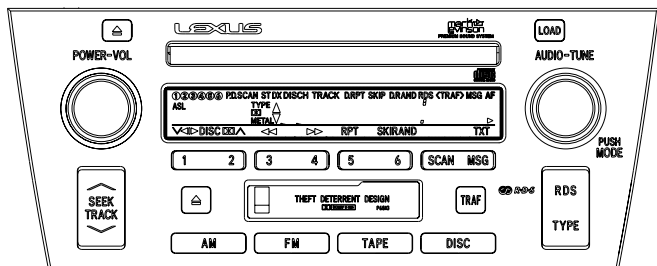

ID No.P6813

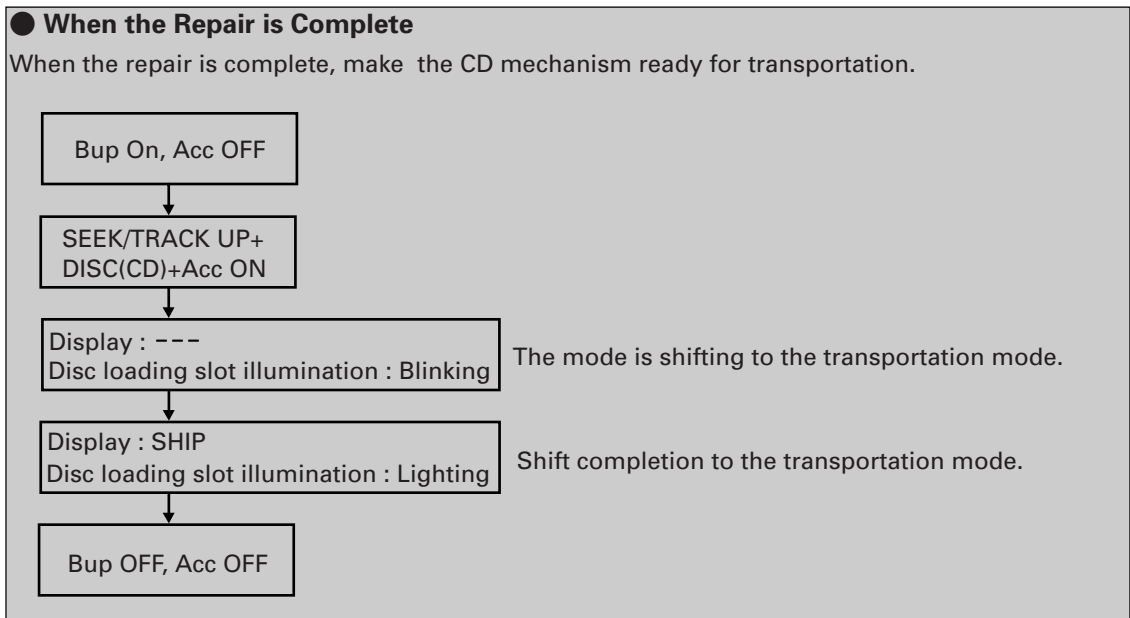

● This service manual should be used together with the following manual(s):

Model No.	Order No.	Mech. Module	Remarks
CX-631	CRT1640	2L	Cassette Mech. Module:Mech.Description, Disassembly
CX-890	CRT2376	G1	CD Mech. Module:Circuit Description, Mech.Description, Disassembly

● **Dolby noise reduction manufactured under license from Dolby Laboratories Licensing Corporation.**

"Dolby" and the double-D symbol are trademarks of Dolby Laboratories Licensing Corporation.

● **See the page 81 of service manual FX-MG9006ZT/UC(CRT2539) for the SELF-DIAGNOSTIC FUNCTION.**

● **Supplementary model is identical to the original except for the addition of following items.**

Description	Part No.
	FX-MG8217ZT-91/UC
Polyethylene Bag	CEG1026
Carton	CHA3117
Contain Box	CHD3117
Protector	CHP2355
Protector	CHP2356

CONTENTS

1. SAFETY INFORMATION	3	7. GENERAL INFORMATION	76
2. EXPLODED VIEWS AND PARTS LIST	4	7.1 DIAGNOSIS	76
3. BLOCK DIAGRAM AND SCHEMATIC DIAGRAM ...	12	7.1.1 TEST MODE	76
4. PCB CONNECTION DIAGRAM	36	7.1.2 DISASSEMBLY	83
5. ELECTRICAL PARTS LIST	60	7.1.3 PCB LOCATIONS	88
6. ADJUSTMENT.....	70	7.1.4 CONNECTOR FUNCTION DESCRIPTION ..	89
		7.2 PARTS	90
		7.2.1 IC	90
		7.2.2 DISPLAY.....	94
		7.3 EXPLANATION.....	95
		7.3.1 SYSTEM BLOCK DIAGRAM	95
		7.3.2 OPERATIONAL FLOW CHART	96
		8. OPERATIONS AND SPECIFICATIONS.....	97

● CD Player Service Precautions

1. Never attempt to turn on this unit when the CD drive mechanism is upside down. Doing so could cause damage or malfunction to the drive mechanism.
2. For pickup unit(CXX1313) handling, please refer to "Disassembly"(see page 83).
During replacement, handling precautions shall be taken to prevent an electrostatic discharge(protection by a short pin).
3. During disassembly, be sure to turn the power off since an internal IC might be destroyed when a connector is plugged or unplugged.
4. Please check the grating after changing the service pickup unit(see page 74).

1. SAFETY INFORMATION

This service manual is intended for qualified service technicians; it is not meant for the casual do-it-yourselfer. Qualified technicians have the necessary test equipment and tools, and have been trained to properly and safely repair complex products such as those covered by this manual. Improperly performed repairs can adversely affect the safety and reliability of the product and may void the warranty. If you are not qualified to perform the repair of this product properly and safely; you should not risk trying to do so and refer the repair to a qualified service technician.

2. EXPLODED VIEWS AND PARTS LIST

2.1 EXTERIOR

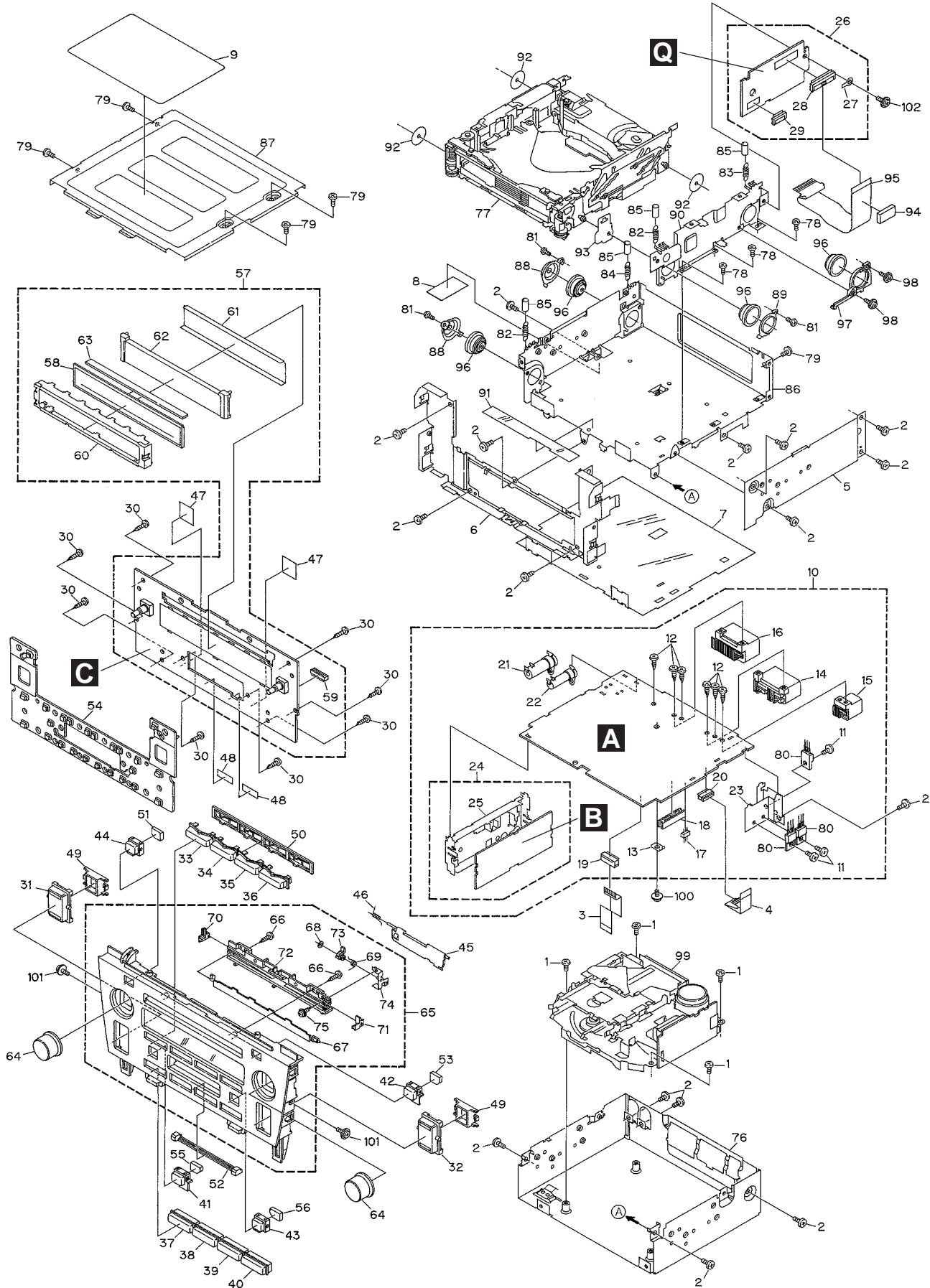

NOTE:

- Parts marked by "*" are generally unavailable because they are not in our Master Spare Parts List.
- Screws adjacent to ∇ mark on the product are used for disassembly.

● EXTERIOR SECTION PARTS LIST

Mark No.	Description	Part No.	Mark No.	Description	Part No.
1	Screw	BMZ26P040FMC	46	Spring	CBH2435
2	Screw	BMZ30P050FMC	47	Seal	CNM7027
3	Connector	CDE6657	48	Seal	CNM7028
4	Connector	CDE6509	49	Holder	CNV6106
5	Chassis	CNA2257	50	Holder	CNV6107
6	Frame	CNC8700	51	Lighting Conductor	CNV6108
7	Insulator	CNM6650	52	Lighting Conductor	CNV6109
8	Seal	CNM7286	53	Lighting Conductor	CNV6118
9	Label	CRW1417	54	Rubber	CNV6119
10	Main Unit	CWM7046	55	Lighting Conductor	CNV6126
11	Screw	BMZ30P060FMC	56	Lighting Conductor	CNV6351
12	Screw(M3x6)	CBA1393	57	Keyboard Unit	CWS1332
13	Terminal(CN800)	CKF1059	58	LCD(LCD901)	CAW1690
14	Plug(CN803)	CKM1221	59	Connector(CN902)	CKS4361
15	Connector(CN802)	CKM1315	60	Holder	CNC8672
16	Connector(CN801)	CKM1322	61	Sheet	CNM6620
17	Plug(CN300)	CKS-291	62	Lighting Conductor	CNV6114
18	Connector(CN301)	CKS3568	63	Connector	CNV6115
19	Connector(CN804)	CKS4361	64	Knob Unit	CXB6372
20	Connector(CN303)	CKS4376	65	Grille Unit	CXB7592
21	86146-48030(ANT1)	CKX1057	66	Screw	BMZ20P080FMC
22	86146-48040(ANT2)	CKX1058	67	Door	CAT2221
23	Holder	CNC8704	68	Washer	CBF1037
24	FM/AM Tuner Unit	CWE1543	69	Spring	CBH2446
25	Holder	CNC6774	70	Lighting Conductor	CNV6110
26	Control Unit	CWM7048	71	Lighting Conductor	CNV6111
27	Terminal(CN703)	CKF1064	72	Holder	CNV6590
28	Connector(CN701)	CKS3989	73	Gear	CNV6726
29	Connector(CN702)	CKS4376	74	Bracket Unit	CXB6083
30	Screw	BPZ20P080FMC	75	Screw	IMS20P030FMC
31	Button(SEEK,TRACK)	CAC6465	76	Chassis Unit	CXB6477
32	Button(RDS,TYPE)	CAC6466	77	Mechanism Assy(Service)	CXX1487
33	Button(1,2)	CAC6467	78	Screw	BMZ20P020FMC
34	Button(3,4)	CAC6468	79	Screw	BMZ26P030FMC
35	Button(5,6)	CAC6469	80	Transistor(Q809,811,812)	2SB1185
36	Button(SCAN,MSG)	CAC6470	81	Screw(M2x2)	CBA1250
37	Button(AM)	CAC6471	82	Spring	CBH2472
38	Button(FM)	CAC6472	83	Spring	CBH2473
39	Button(TAPE)	CAC6473	84	Spring	CBH2478
40	Button(DISC)	CAC6474	85	Tube	CDM1028
41	Button(TAPE EJECT)	CAC6475	86	Chassis	CNA2256
42	Button(LOAD)	CAC6476	87	Case	CNB2549
43	Button(TRAF)	CAC6477	88	Holder	CNC7477
44	Button(CD EJECT)	CAC6493	89	Holder	CNC7826
45	Door	CAT2116	90	Holder	CNC8701

FX-MG8217ZT, MG8217ZT-91

Mark No.	Description	Part No.
91	Insulator	CNM5969
92	Sheet	CNM5981
93	Sheet	CNM6318
94	Cushion	CNM7023
95	PCB	CNP5516
96	Damper	CNV5120
97	Holder	CNV5543
98	Screw	IMS20P040FMC
99	Cassette Mechanism Module	EXK3891
100	Screw	IMS26P040FMC
101	Screw	ISS26P060FMC
102	Screw	PMB26P060FMC

● CD MECHANISM SECTION PARTS LIST

Mark No.	Description	Part No.	Mark No.	Description	Part No.
1-9	●●●●●		59	Gear	CNC7236
10	CD Core Unit(Servo Unit)	CWX2421	60	Gear	CNC9512
11	Connector(CN101)	CKS2764	61	Lever	CNC7243
12	Connector(CN301)	CKS3966	62	Lever	CNC7244
13	Connector(CN201)	CKS3991	63	Lever	CNC7245
14	CD Core Unit(STS Unit)	CWX2422	64	Lever	CXB4944
15	Connector(CN701)	CKS3989	65	Cover	CNC7441
16	Connector(CN801)	CKS3989	66	Holder Unit	CXB4946
17	Connector(CN802)	CKS4054	67	Lever	CNC9088
18	Screw	CBA1037	68	Gear	CNC8140
19	Screw	CBA1041	69	Sheet	CNM6840
20	Screw	CBA1076	70	PCB	CNP5764
21	Screw	CBA1250	71	PCB	CNP6010
22	Washer	CBA1529	72	Gear	CNR1479
23	Screw	CBA1452	73	Gear	CNR1481
24	Screw	CBA1453	74	Gear	CNR1495
25	Screw	CBA1479	75	Gear	CNR1501
26	Washer	CBF1037	76	Gear	CNR1502
27	Washer	CBF1038	77	Gear	CNR1540
28	Washer	CBF1039	78	Gear	CNR1541
29	Washer	CBF1064	79	Belt	CNT1080
30	Spring	CBH2007	80	Worm Gear	CNV5046
31	Spring	CBH2271	81	Gear	CNV5047
32	Spring	CBH2274	82	Gear	CNV5048
33	Spring	CBH2014	83	Gear	CNV5049
34	Spring	CBH2015	84	Holder	CNV5056
35	Spring	CBH2016	85	Pulley	CNV5058
36	Spring	CBH2017	86	Arm	CNV5061
37	Spring	CBH2290	87	Spacer	CNV5066
38	Spring	CBH2366	88	Arm	CNV5189
39	Spring	CBH2064	89	Cover	CNV5207
40	Spring	CBH2195	90	Cover	CNV5424
41	Spring	CBH2196	91	Cover	CNV5425
42	Spring	CBH2224	92	Lever	CNV5427
43	Spring	CBH2250	93	Arm	CNV5491
44	Screw	CBA1082	94	Gear	CNV5519
45	Roller	CLA3154	95	Holder	CNV5648
46	Roller	CLA3157	* 96	Composite PCB	CNX3501
47	Roller	CLA3159	* 97	Composite PCB	CNX3502
48	Roller	CLA3160	98	Chassis Unit	CXB5940
49	Shaft	CLA3179	99	Frame Unit	CXB5806
50	Spacer	CLA3194	100	Lever Unit	CXB6026
51	Roller	CLA3248	101	Arm Unit	CXB2704
52	Bush	CLA3353	102	Lever Unit	CXB2708
* 53	Shaft	CLA3469	103	Lever Unit	CXB2709
54	Shaft	CLA3693	104	Lever Unit	CXB4949
55	Steer	CNC7215	105	Arm Unit	CXB2712
56	Steer	CNC7216	106	Lever Unit	CXB4948
57	Cam	CNC8774	107	Lever Unit	CXB2714
* 58	Holder	CNC7235	108	Carriage Mechanism Unit(G1)	CXB4941

Mark No.	Description	Part No.	Mark No.	Description	Part No.
109	Screw	CBA1041	159	Screw	CBA1453
110	Screw	CBA1250	160	Washer	CBF1038
111	Screw	CBA1362	161	Loading Arm R Assy(Service)	CXX1486
112	Screw	CBA1471	162	Washer	CBF1074
113	Washer	CBF1038	163	Spring	CBH2136
114	Spring	CBH2008	* 164	Arm	CNC7241
115	Spring	CBH2009	* 165	Arm	CXB6911
116	Spring	CBH2010	166	Holder	CBL1508
117	Spring	CBL1335	167	Belt	CNT1079
118	Roller	CLA3913	168	Holder	CNV5055
* 119	Bracket	CNC7228	169	Pulley	CNV5057
120	Guide Unit	CXB4417	170	Roller	CNV6209
121	Cover	CNC7628	171	Guide	CNV5125
122	Sheet	CNM6414	* 172	Bracket Unit	CXB5937
123	Sheet	CNM5378	173	Roller Gear Unit	CXB3176
124	•••••		* 174	Motor Unit(M2 LOAD)	CXB3177
125	Sheet	CNM5827	175	Screw	JFZ14P020FMC
126	PCB	CNP6164	176	Loading Arm R Assy	CXB5839
127	Ball	CNR1189	177	Screw	CBA1453
128	Bearing	CNR1423	178	Washer	CBF1074
129	Belt	CNT1079	179	Spring	CBH2136
130	Holder	CNV5037	* 180	Arm	CNC7242
131	Guide	CNV5040	* 181	Arm	CXB6912
132	Clamper	CNV5042	182	Screw	JFZ20P014FMC
133	Rack	CNV5111	183	Roller	CNV6209
134	Arm	CNV5579	184	Roller Gear Unit	CXB3176
135	Holder	CNV5759	185	Guide	CNV5126
* 136	Chassis	CXB6025	186	Switch(S885 MAX DETECT)	CSN1052
137	Arm Unit	CXB2705	187	LED(D883)	CL205IRXTU
138	Motor Unit(M4 CARRIAGE)	CXB3178	188	Photo-transistor(Q881)	CPT230SCTD
139	Screw Unit	CXB3179	189	LED(D891,892)	CL205IRXTU
140	Lever Unit	CXB4450	190	Switch(S887 CLAMP)	CSN1051
141	Bracket	CNC8584	191	Switch(S886 ELV HOME)	CSN1052
142	Spacer	CNM6345	192	Bracket Unit	CXB6086
143	Motor(M5 SPINDLE)	CXM1120	193	Photo-transistor(Q851,852)	CPT230SCTD
144	Screw	JFZ14P020FZK	194	Resistor(R856)	RS1/8S911J
145	Washer	YE15FUC	195	Resistor(R857)	RS1/8S821J
146	Arm Unit	CXB6052	196	Photo-interrupter(Q1)	RPI-221
147	Arm Unit	CXB6053	197	Screw	CBA1387
148	Tray Assy	CXB4307	198	Pickup Unit(Service)(P8)	CXX1313
149	Spring	CBH2269	199	Spring	CBL1467
150	Sheet	CNM7109	200-202	•••••	
151	Cam Motor Assy	CXB6928	203	Sheet	CNM7025
152	•••••		204	Inductor(L1,2,801,802)	LCYBR15J1608
* 153	Bracket Unit	CXB5201			
* 154	Motor Unit(M1 Cam Gear)	CXB6929			
* 155	Motor Unit(M3 ELV)	CXB3175			
156	Screw	JFZ20P025FMC			
157	Loading Arm L Assy	CXB6957			
158	Loading Arm L Assy(Service)	CXX1469			

2.3 CASSETTE MECHANISM MODULE

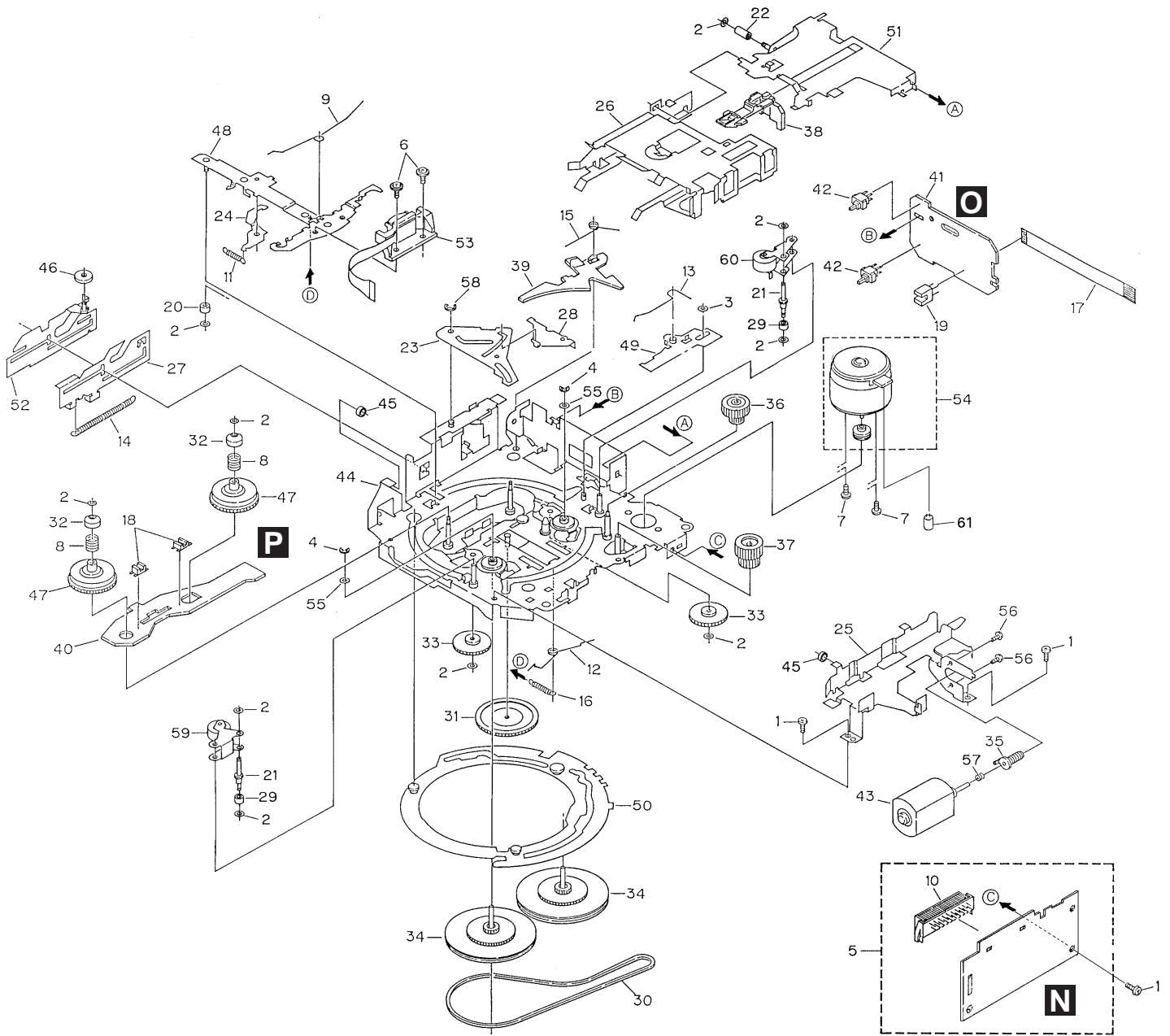

● CASSETTE MECHANISM MODULE SECTION PARTS LIST

Mark No.	Description	Part No.	Mark No.	Description	Part No.
1	Screw	BSZ20P040FMC	31	Gear	ENV1347
2	Washer	CBF1037	32	Collar	ENV1508
3	Washer	CBF1038	33	Gear	ENV1350
4	Washer	CBG1003	34	Flywheel	ENV1500
5	Deck Unit	EWM1030	35	Worm Gear	ENV1439
6	Screw(M2x5)	EBA1028	36	Worm Wheel	ENV1440
7	Screw(M2x2.5)	CBA1037	37	Gear	ENR1037
8	Spring	EBH1531	38	Lever	ENV1533
9	Spring	EBH1589	39	Arm	ENV1525
10	Connector(CN251)	CKS3540	40	Gathering PCB	ENX1037
11	Spring	EBH1515	41	Gathering PCB	ENX1060
12	Spring	EBH1587	42	Switch(S1)(S2)	ESG1004
13	Spring	EBH1517	43	Motor Unit(M2)(SUB)	EXA1382
14	Spring	EBH1518	44	Chassis Unit	EXA1559
15	Spring	EBH1519	45	Tube	ENM1039
16	Spring	EBH1537	46	Roller	ENR1027
17	Cord	EDD1027	47	Reel Unit	EXA1560
18	Photo-interrupter(EGN2,3)	EGN1006	48	Head Base Unit	EXA1434
19	Photo-interrupter(EGN1)	EGN1005	49	Lever Unit	EXA1578
20	Roller	ENR1031	50	Gear Unit	EXA1545
21	Shaft	ELA1362	51	Frame Unit	EXA1476
22	Roller	ELA1348	52	Lever Unit	EXA1439
23	Arm	ENC1490	53	Head Assy(HD1)	EXA1594
24	Arm	ENC1397	54	Motor Unit(M1)(MAIN)	EXA1499
25	Guide	ENC1519	55	Washer	HBF-179
26	Holder	ENC1516	56	Screw	JGZ20P025FNI
27	Lever	ENC1448	57	Spring	EBH1545
28	Arm	ENC1488	58	Washer	YE20FUC
29	Roller	ENR1023	59	Pinch Roller Unit	EXA1533
30	Belt	ENT1027	60	Pinch Roller Unit	EXA1532
			61	Capacitor(C1)	CEAL4R7M35

3. BLOCK DIAGRAM AND SCHEMATIC DIAGRAM

3.1 BLOCK DIAGRAM

A

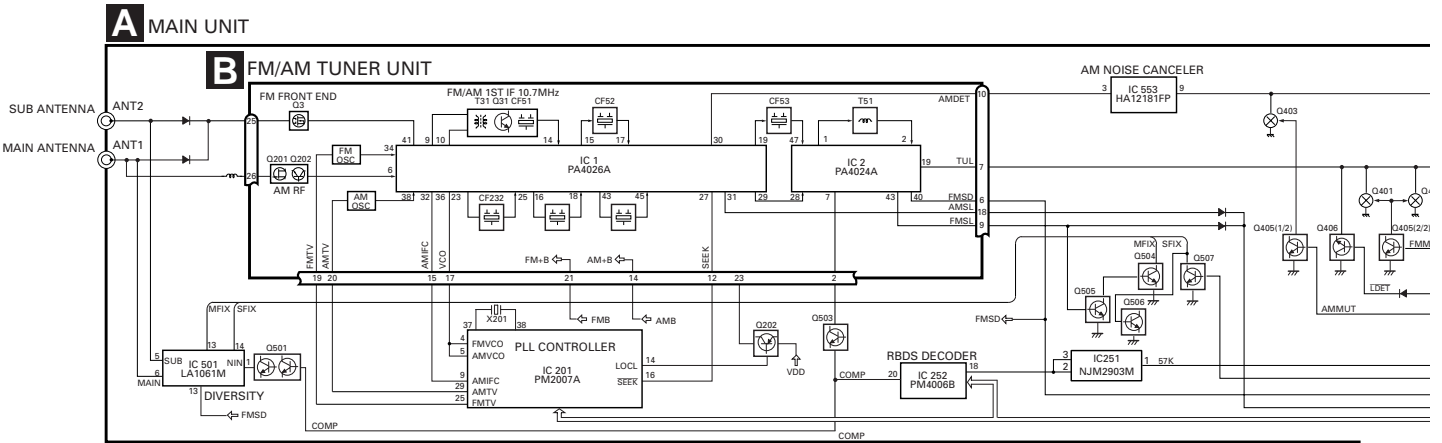

PICKUP UNIT(SERVICE)

B

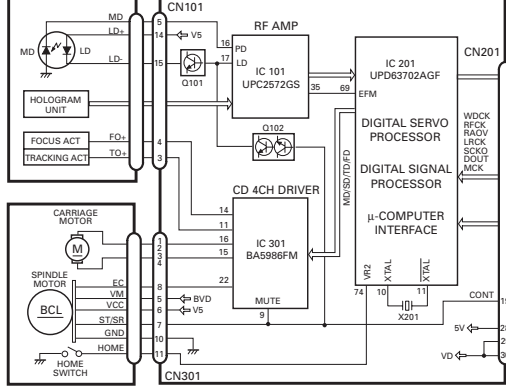

G CD CORE UNIT(STS UNIT)

Q CONTROL UNIT

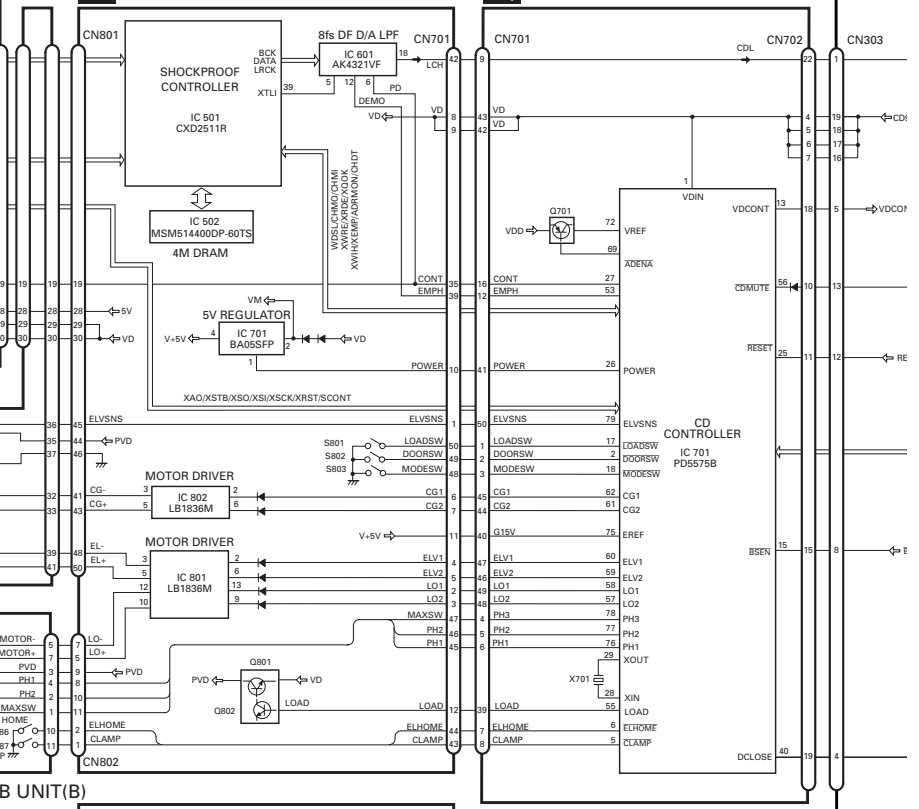

D MOTOR PCB(B)

E CD CORE UNIT(SERVO UNIT)

F MOTOR PCB(A)

M PCB UNIT(D)

K LOAD MOTOR PCB

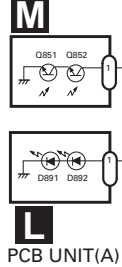

I PCB UNIT(E)

H PCB UNIT(B)

N DECK UNIT

P REEL UNIT

O PCB UNIT

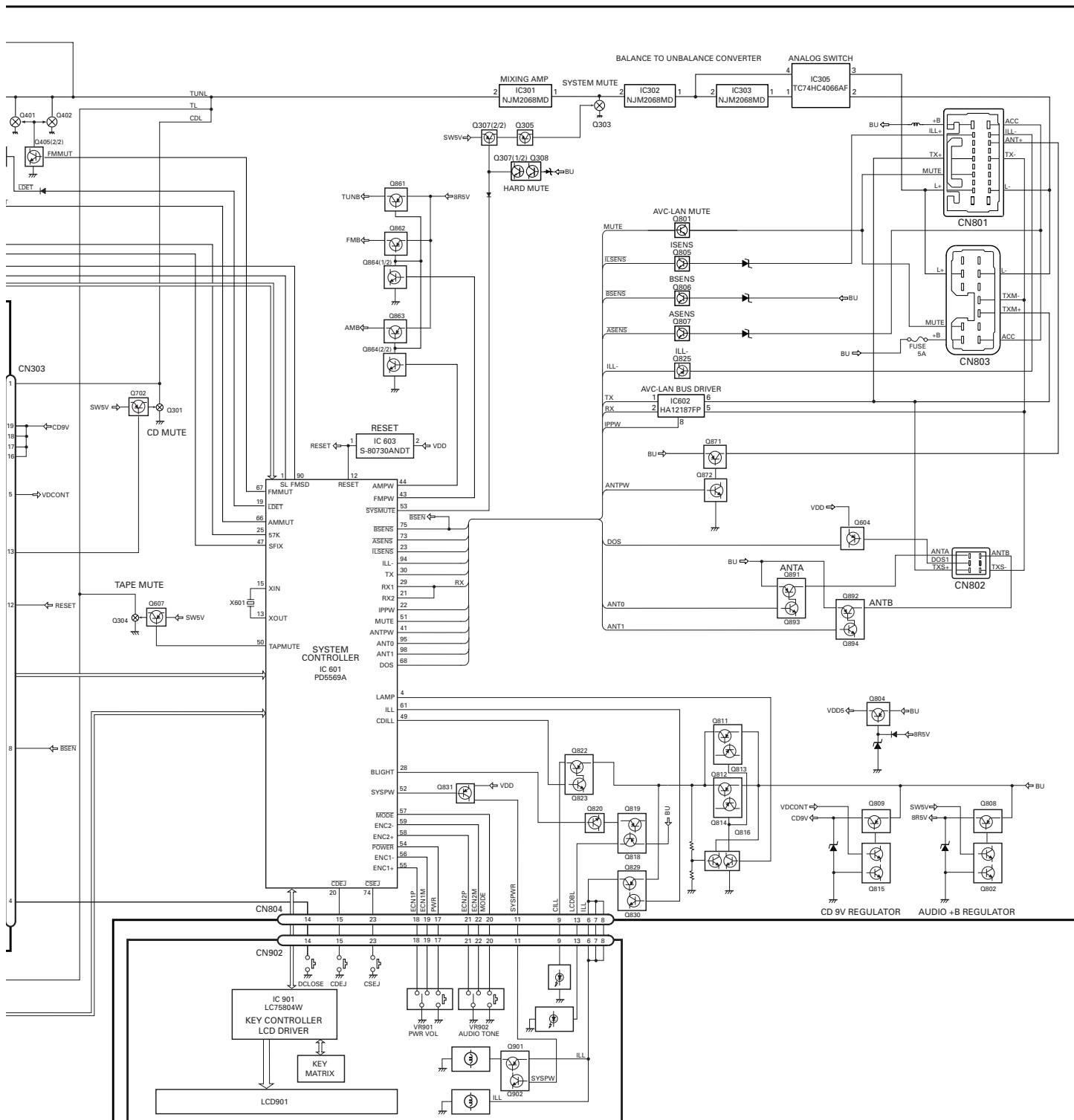

C KEYBOARD UNIT

3.2 OVERALL CONNECTION DIAGRAM(GUIDE PAGE)

A-a

Note: When ordering service parts, be sure to refer to "EXPLODED VIEWS AND PARTS LIST" or "ELECTRICAL PARTS LIST".

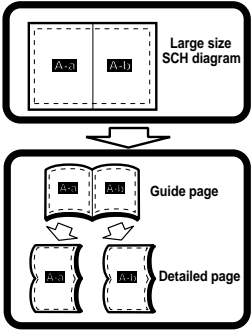

A MAIN UNIT

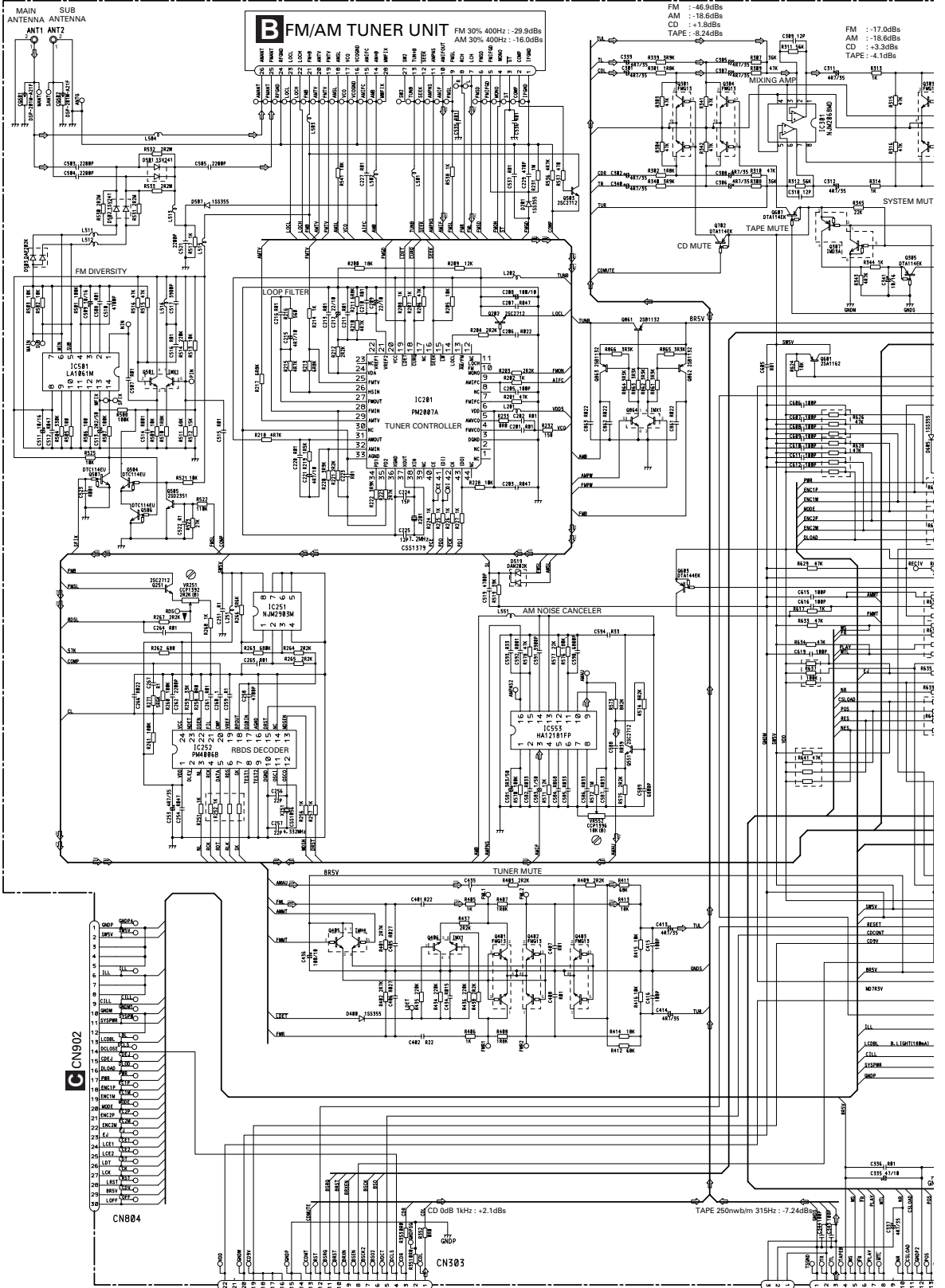

A-b

A

B

C

D

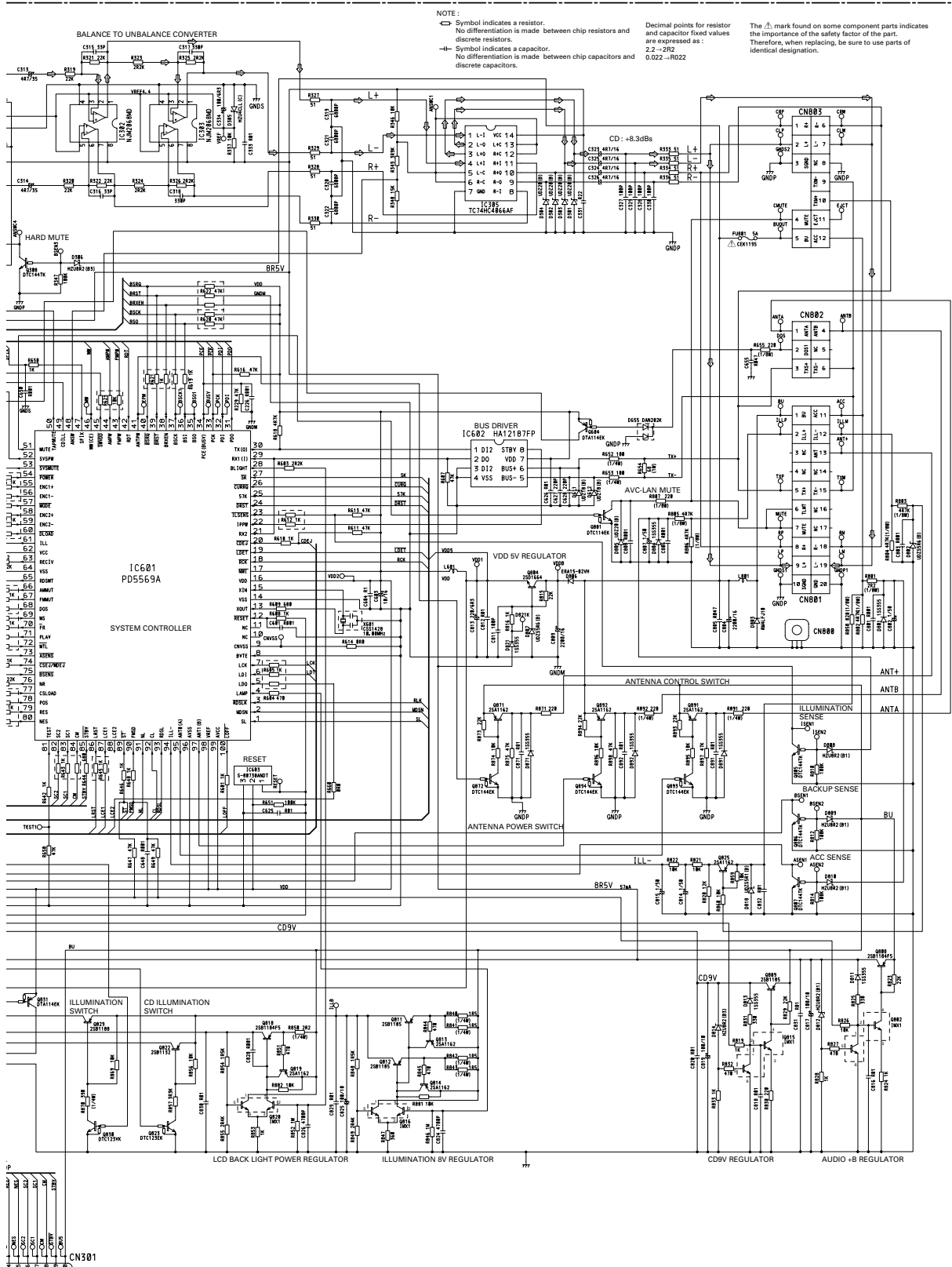

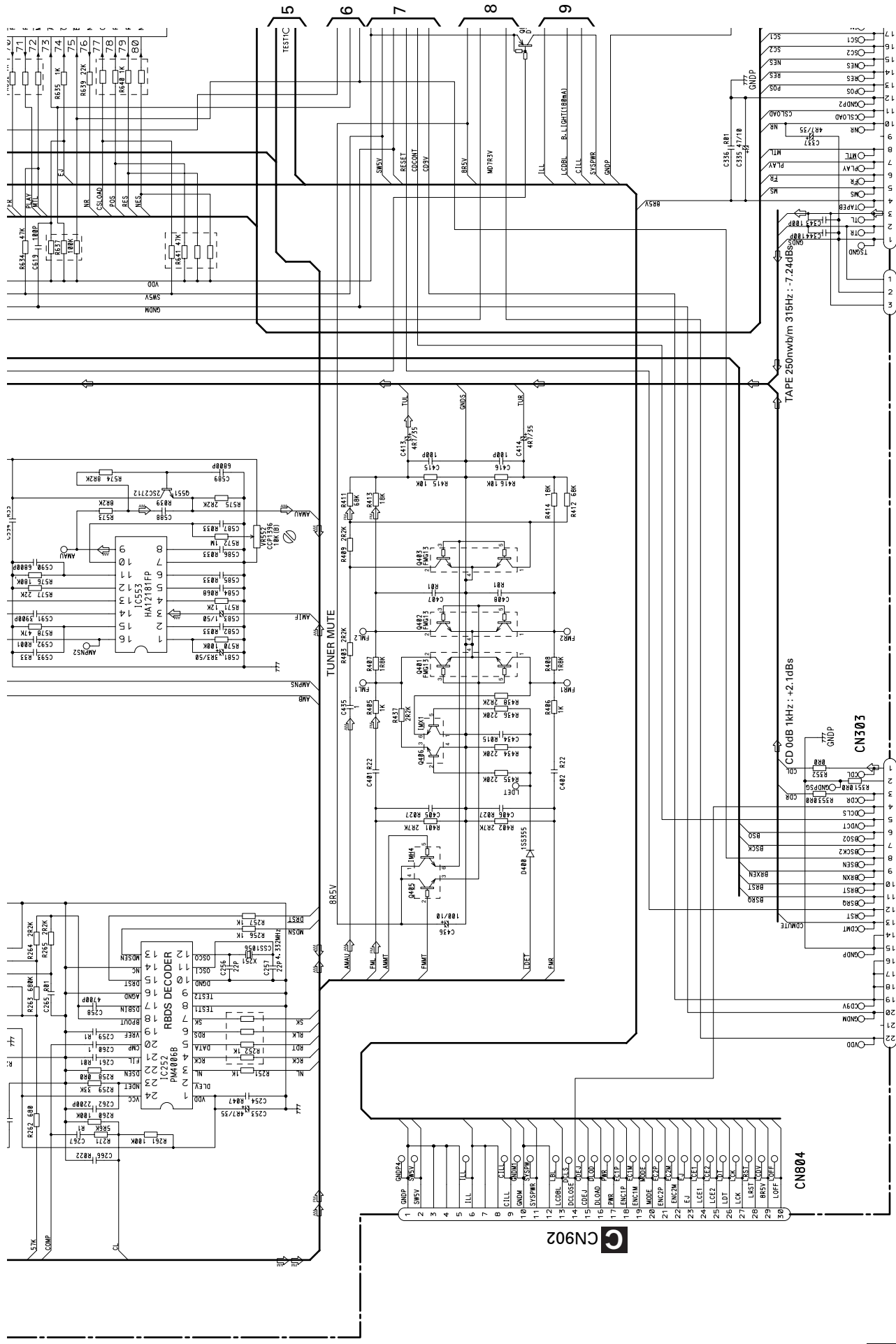

N CN251

A-a A-b

Q CN702

C CN902

CN604

CN503

A-a

NOTE:
 □ Symbol indicates a resistor.
 □ No differentiation is made between chip resistors and discrete resistors.
 □ —□ Symbol indicates a capacitor.
 □ No differentiation is made between chip capacitors and discrete capacitors.

Decimal points for resistor and capacitor fixed values are expressed as:
 2.2 → 2R2
 0.022 → R022

The Δ mark found on some component parts indicates the importance of the safety factor of the part. Therefore, when replacing, be sure to use parts of identical designation.

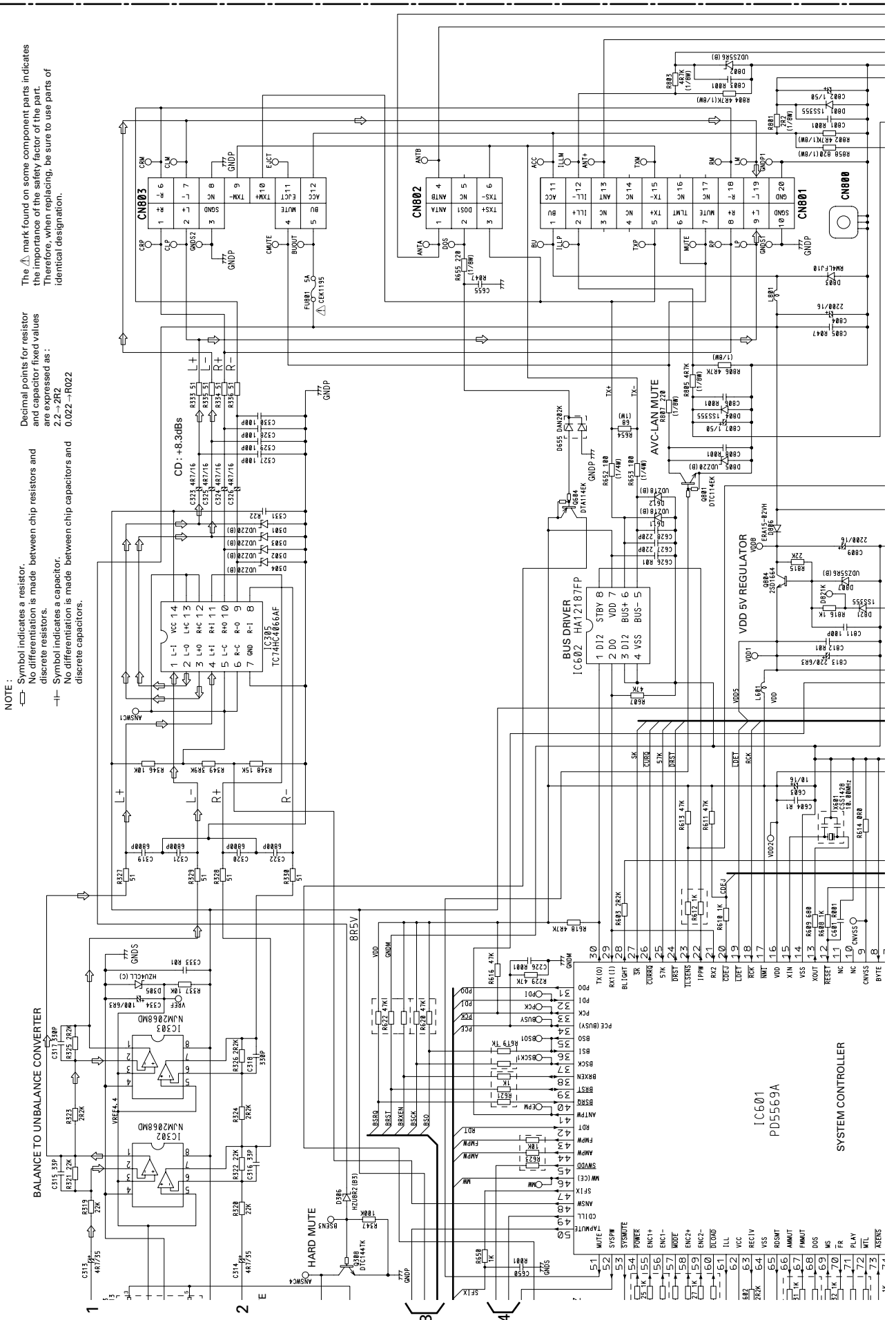

Pin	Signal
51	MUTE
52	TAPOUT
53	SYSTEM
54	POWER
55	ENC1+
56	ENC1-
57	MODE
58	ENC2+
59	ENC2-
60	DIOD
61	ILL
62	VCC
63	RECIV
64	VSS
65	ASMT
66	AMUT
67	FMUT
68	DOS
69	AS
70	FR
71	FLY
72	MTL
73	SENSE

A-a A-b

A

B

C

D

E

A

B

C

D

E

1 2 3 4

FX-MG8217ZT.MG8217ZT-91

3.3 FM/AM TUNER UNIT

B FM/AM TUNER UNIT

A

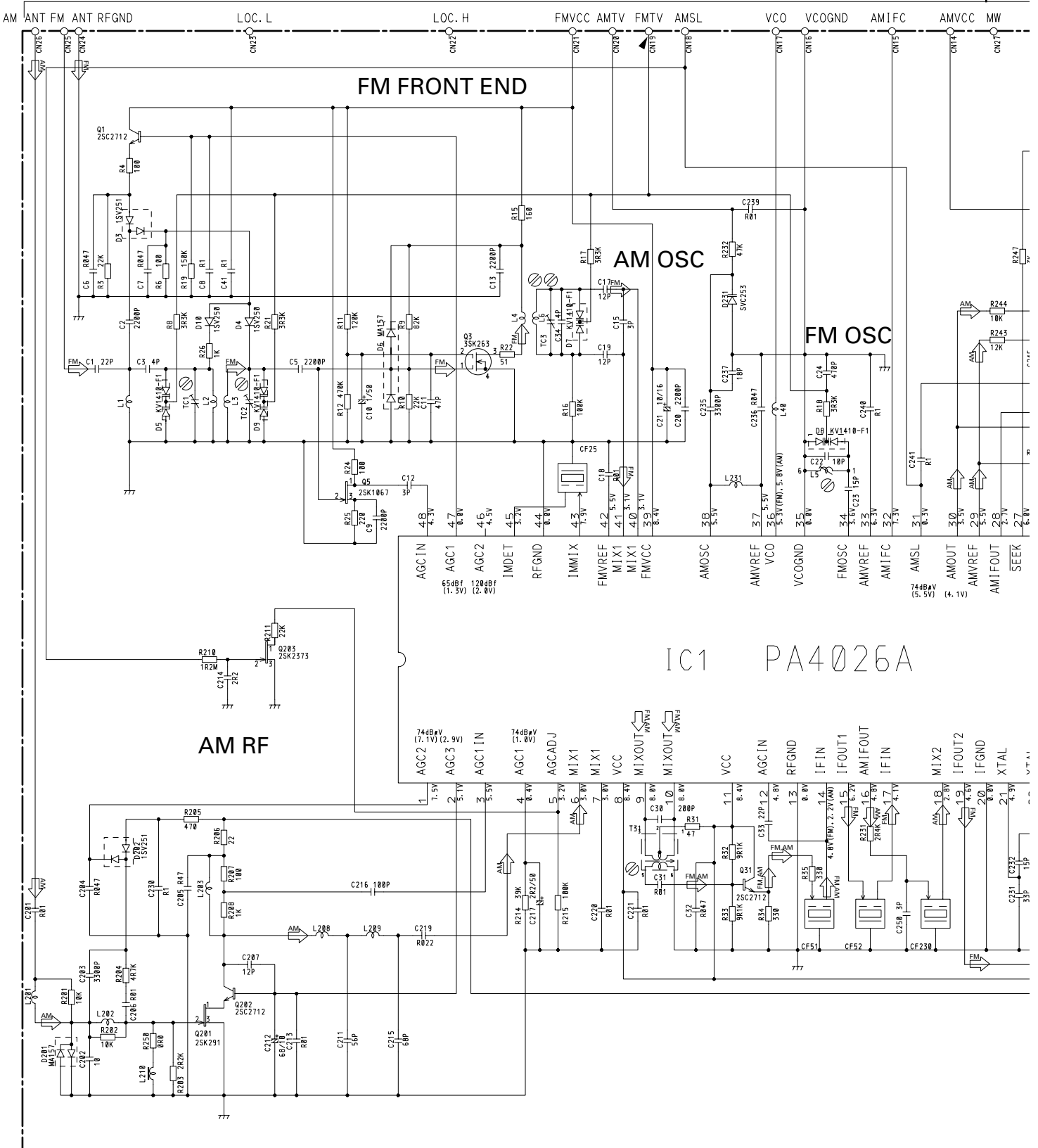

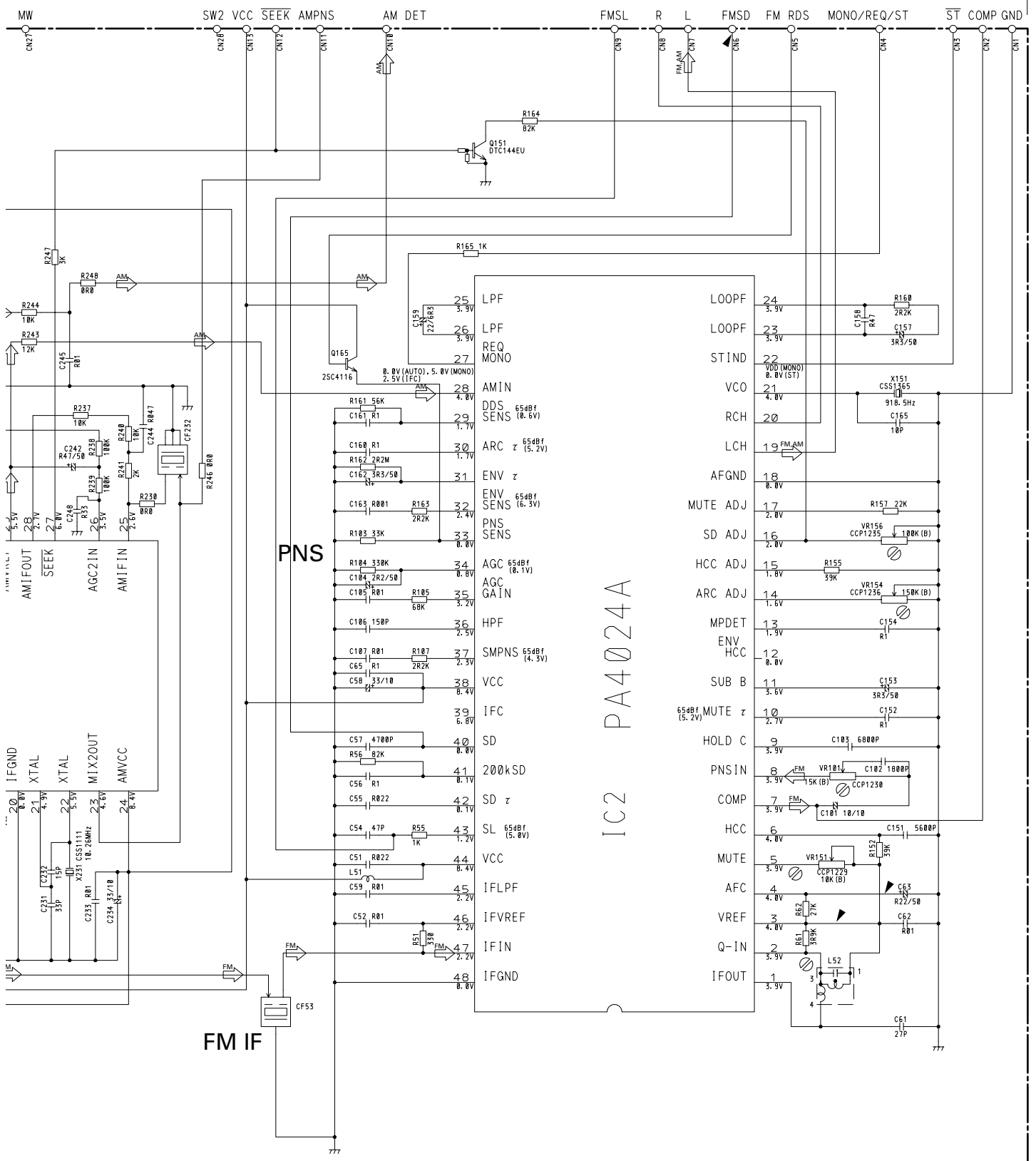

A

B

C

D



3.4 KEYBOARD UNIT

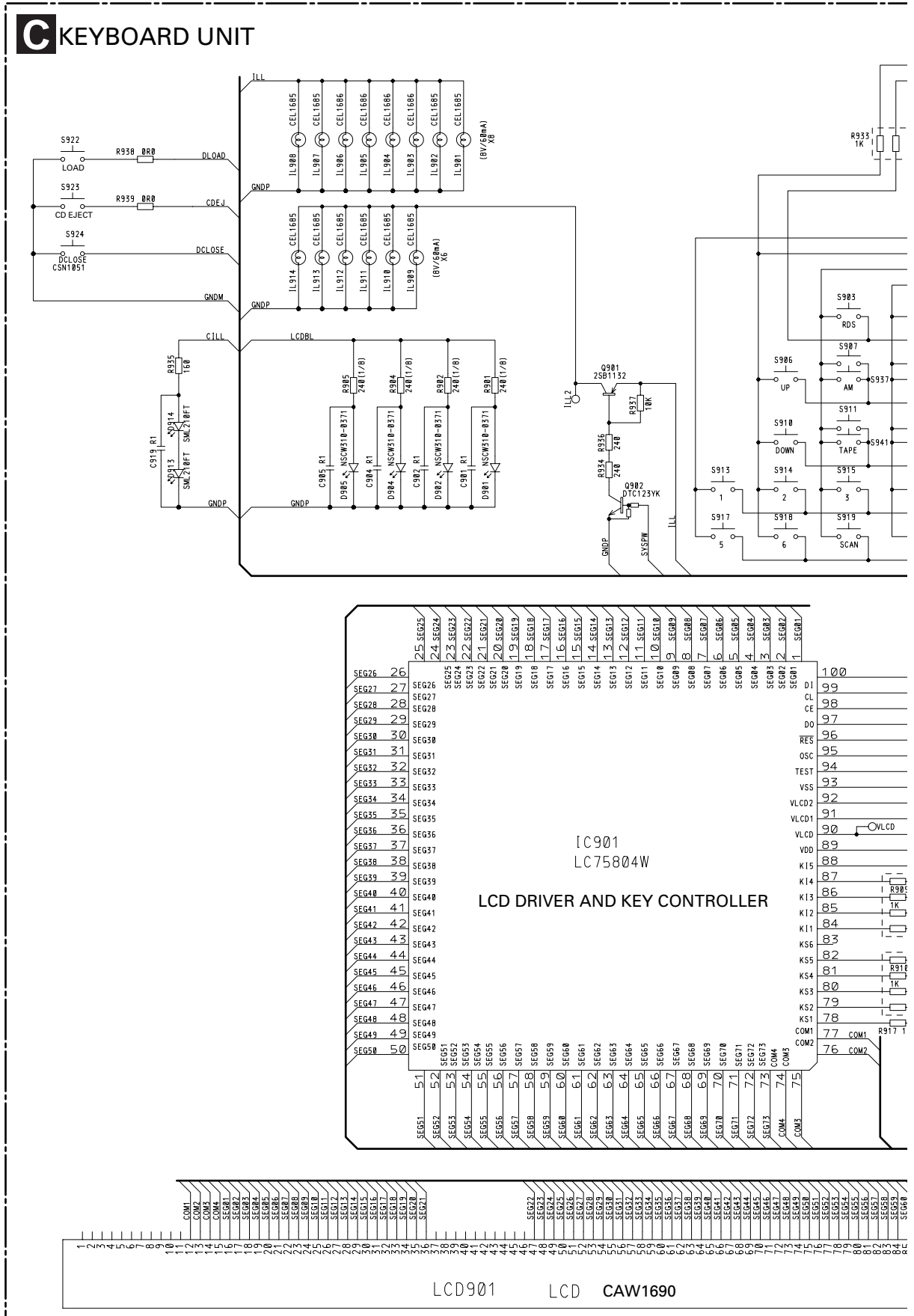

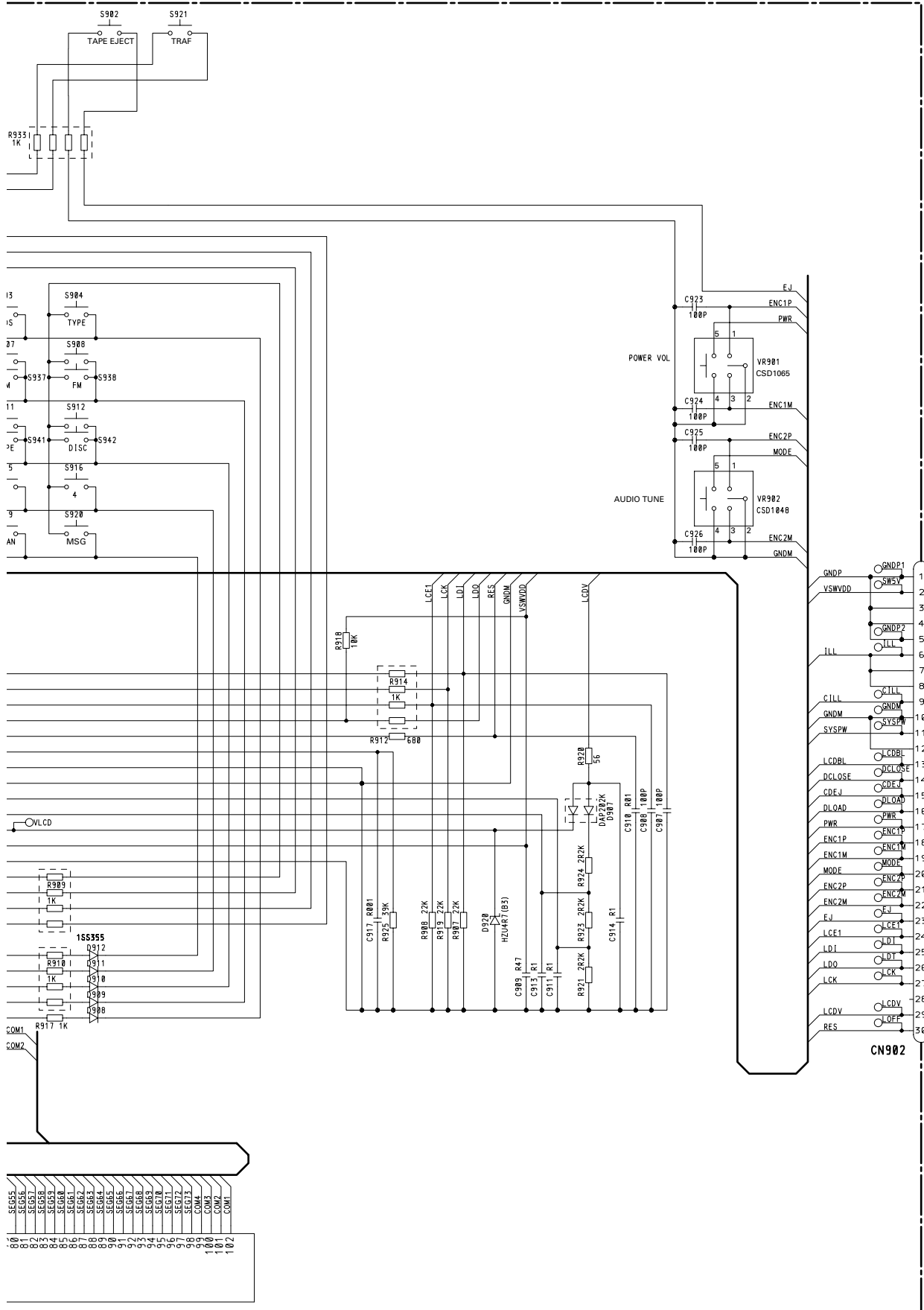

SE655	COM1
SE656	COM2
SE657	COM3
SE658	COM4
SE659	COM5
SE660	COM6
SE661	COM7
SE662	COM8
SE663	COM9
SE664	COM10
SE665	COM11
SE666	COM12
SE667	COM13
SE668	COM14
SE669	COM15
SE670	COM16
SE671	COM17
SE672	COM18
SE673	COM19
SE674	COM20
SE675	COM21
SE676	COM22
SE677	COM23
SE678	COM24
SE679	COM25
SE680	COM26
SE681	COM27
SE682	COM28
SE683	COM29
SE684	COM30
SE685	COM31
SE686	COM32
SE687	COM33
SE688	COM34
SE689	COM35
SE690	COM36
SE691	COM37
SE692	COM38
SE693	COM39
SE694	COM40
SE695	COM41
SE696	COM42
SE697	COM43
SE698	COM44
SE699	COM45
SE700	COM46
SE701	COM47
SE702	COM48
SE703	COM49
SE704	COM50

A

B

C

D

A CN804

CN902



3.5 CD CORE UNIT(SERVO UNIT)

E CD CORE UNIT(SERVO UNIT)

A

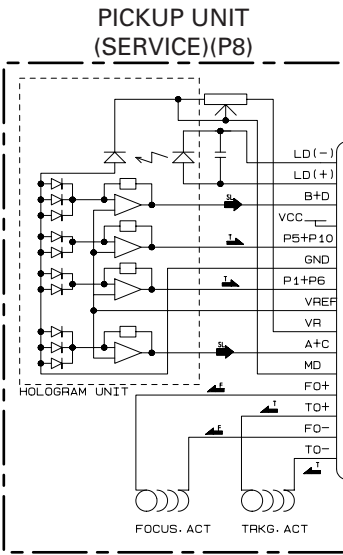

SIGNAL LINE
 FOCUS SERVO LINE
 TRACKING SERVO LINE
 CARRIAGE SERVO LINE
 SPINDLE SERVO LINE

B

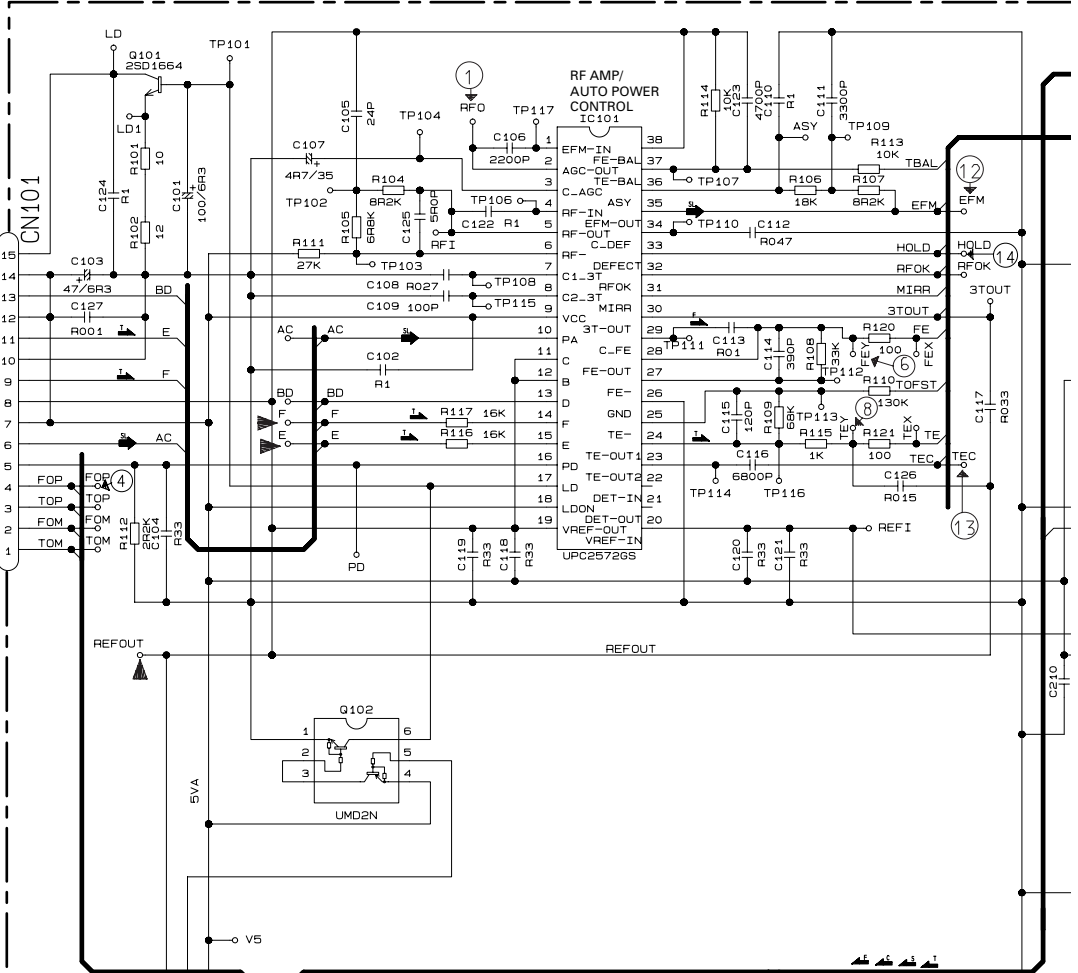

C

D MOTOR PCB(B)

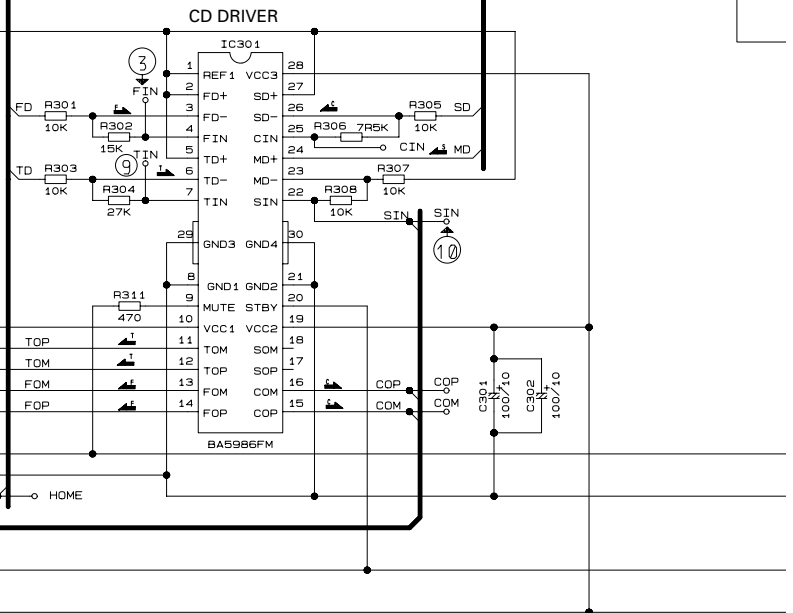
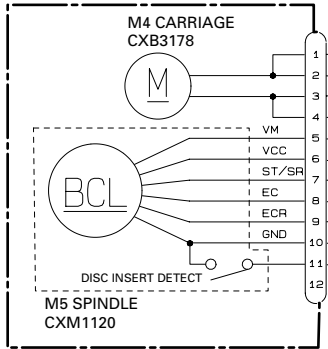

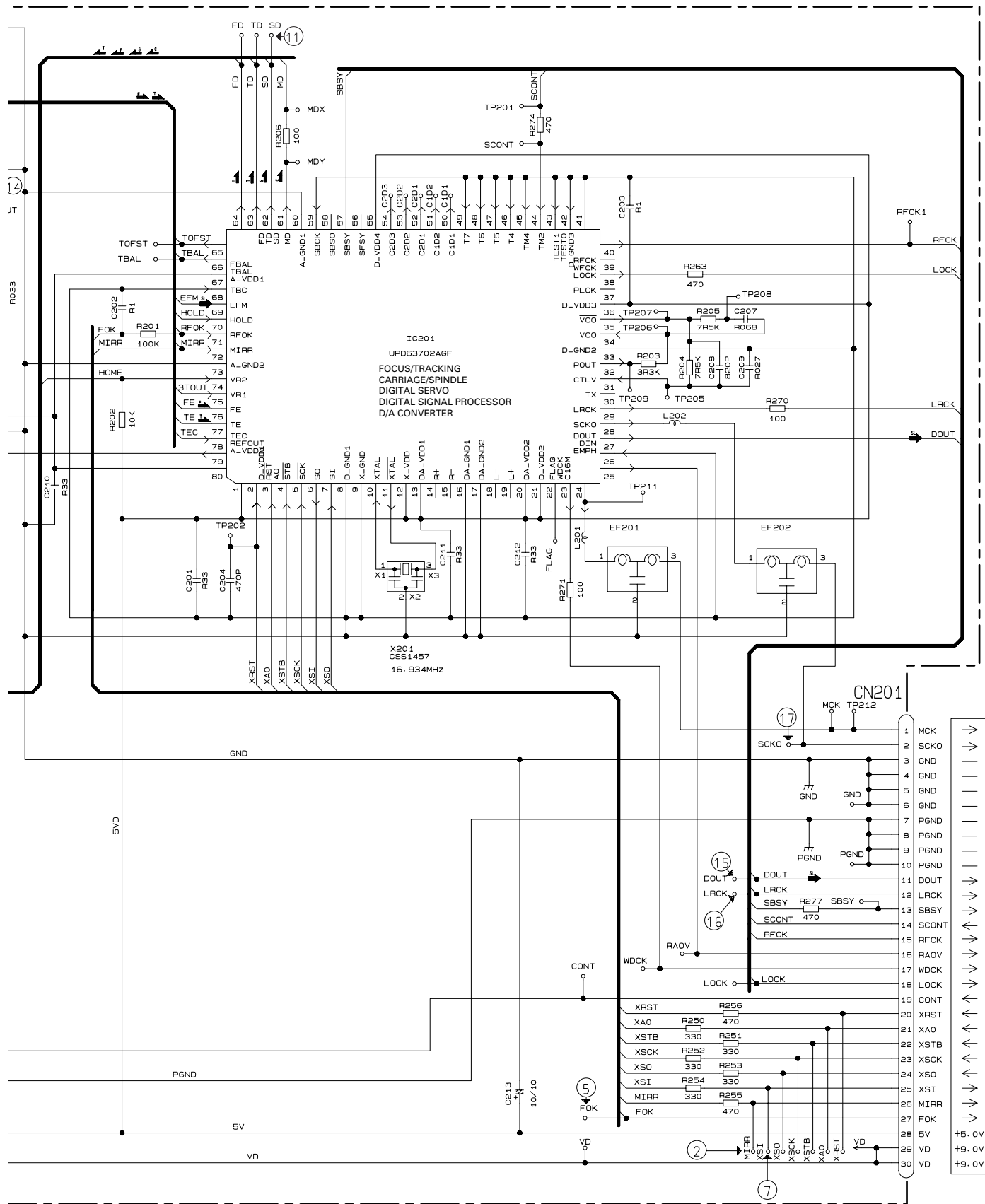

A
B
C
D
E
F
G
H
I
J
K
L
M
N
O
P
Q
R
S
T
U
V
W
X
Y
Z

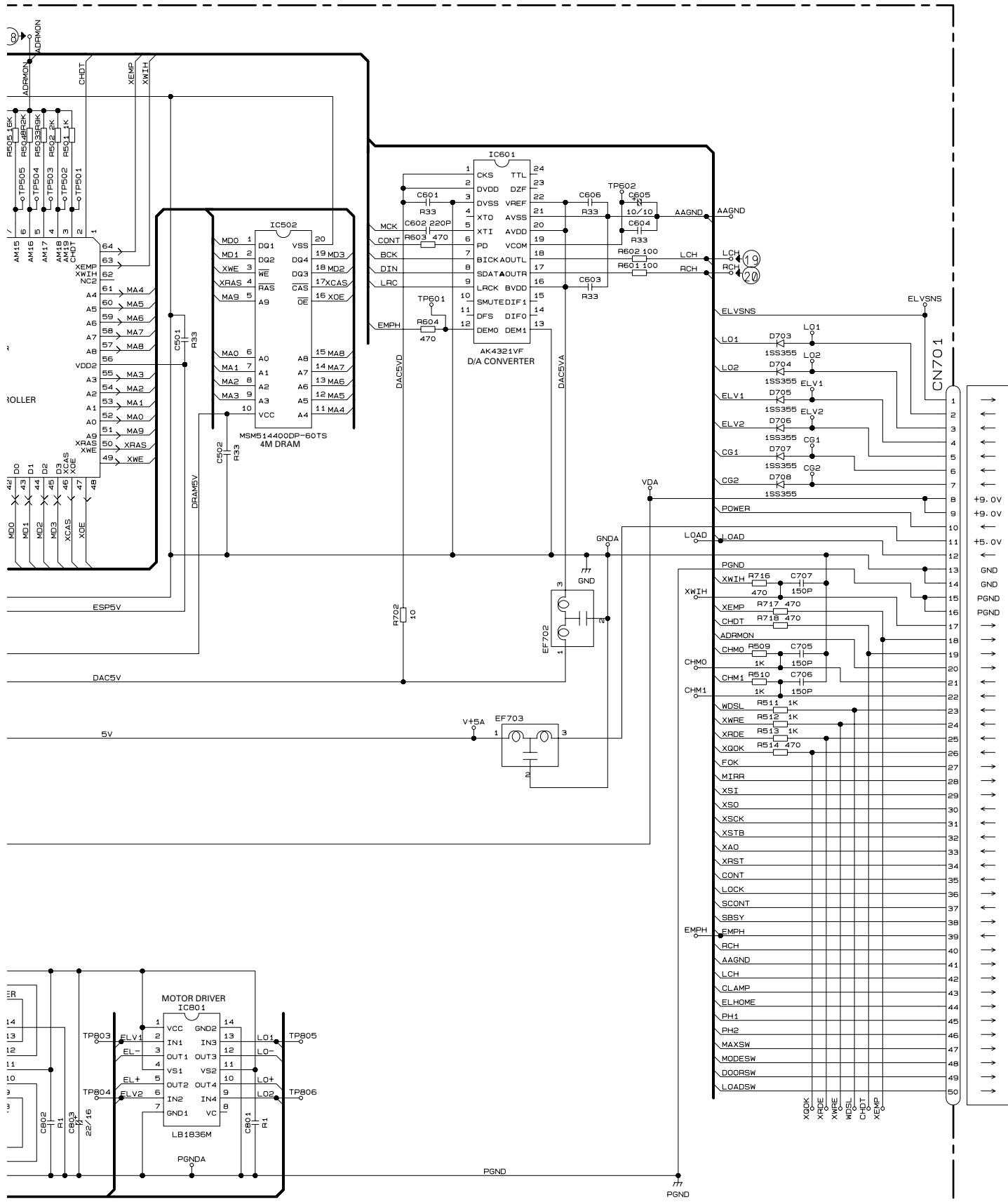

A

B

C

D

Q CN701



Note:1. The encircled numbers denote measuring pointes in the circuit diagram.
 2. Reference voltage
 REFOUT:2.5V

● Waveforms

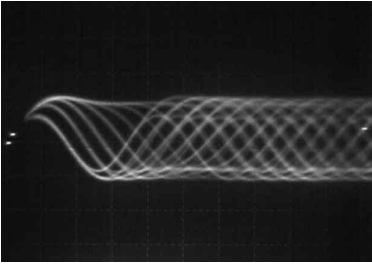
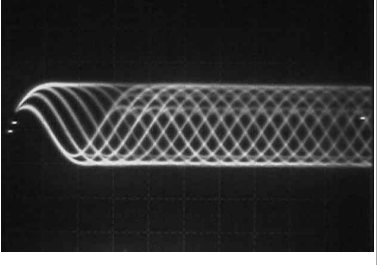
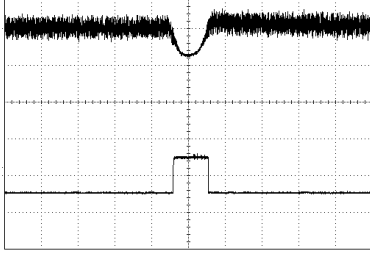
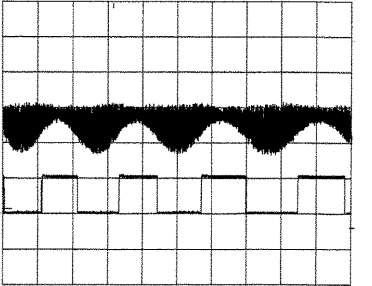
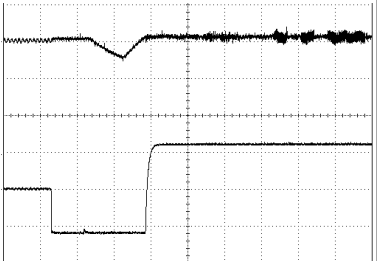
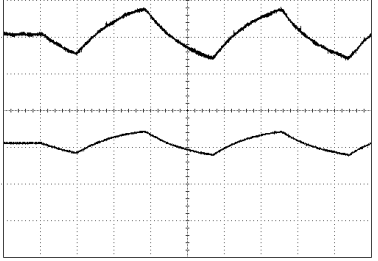
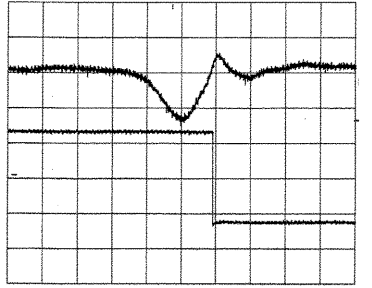
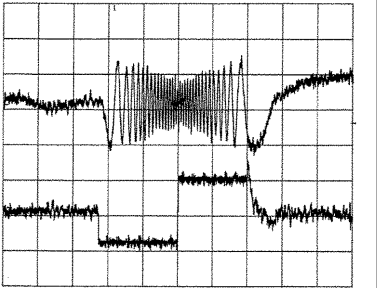
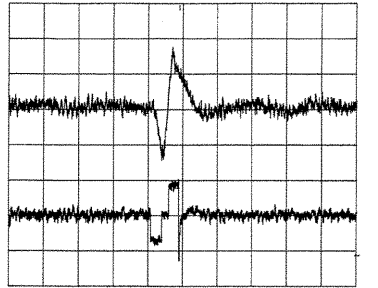
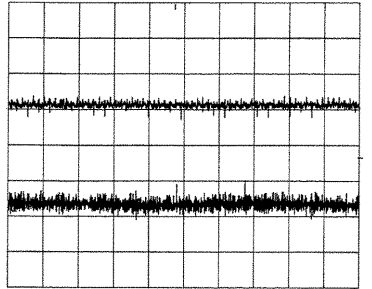
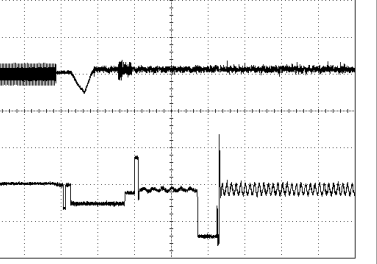
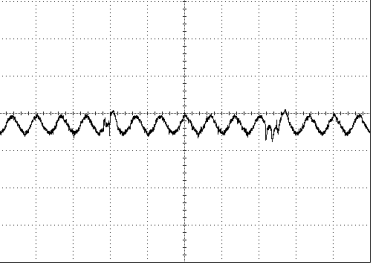
<p>① RFO 0.5V/div. 0.2μs/div. Normal mode: play</p> 	<p>① RFO 0.5V/div. 0.5μs/div. Test mode</p> 	<p>① CH1: RFO 1V/div. 0.5ms/div. ② CH2: MIRR 5V/div. Normal mode: The defect part passes 500μs/div.</p> 
<p>① CH1: RFO 1V/div. 0.5ms/div. ② CH2: MIRR 5V/div. Test mode: Tracking open</p> 	<p>③ CH1: FIN 0.5V/div. 0.2s/div. ⑤ CH2: FOK 2V/div. Normal mode: Focus close</p> 	<p>③ CH1: FIN 0.5V/div. 0.2s/div. ④ CH2: FOP 2V/div. Test mode: No disc, Focus close</p> 
<p>⑥ CH1: FEY 0.5V/div. 1ms/div. ⑦ CH2: XSI 2V/div. Normal mode: Focus close</p> 	<p>⑧ CH1: TEY 0.5V/div. 0.5ms/div. ⑨ CH2: TIN 0.5V/div. Test mode: 32 tracks jump (FWD)</p> 	<p>⑧ CH1: TEY 0.5V/div. 0.5ms/div. ⑨ CH2: TIN 0.5V/div. Test mode: Single jump (FWD)</p> 
<p>⑥ CH1: FEY 0.1V/div. 20ms/div. ③ CH2: FIN 0.2V/div. Normal mode: Play</p> 	<p>③ CH1: FIN 0.5V/div. 0.5s/div. ⑩ CH2: SIN 1V/div. Normal mode: Focus close</p> 	<p>⑩ SIN 0.5V/div. 0.1s/div. Normal mode: Play</p> 

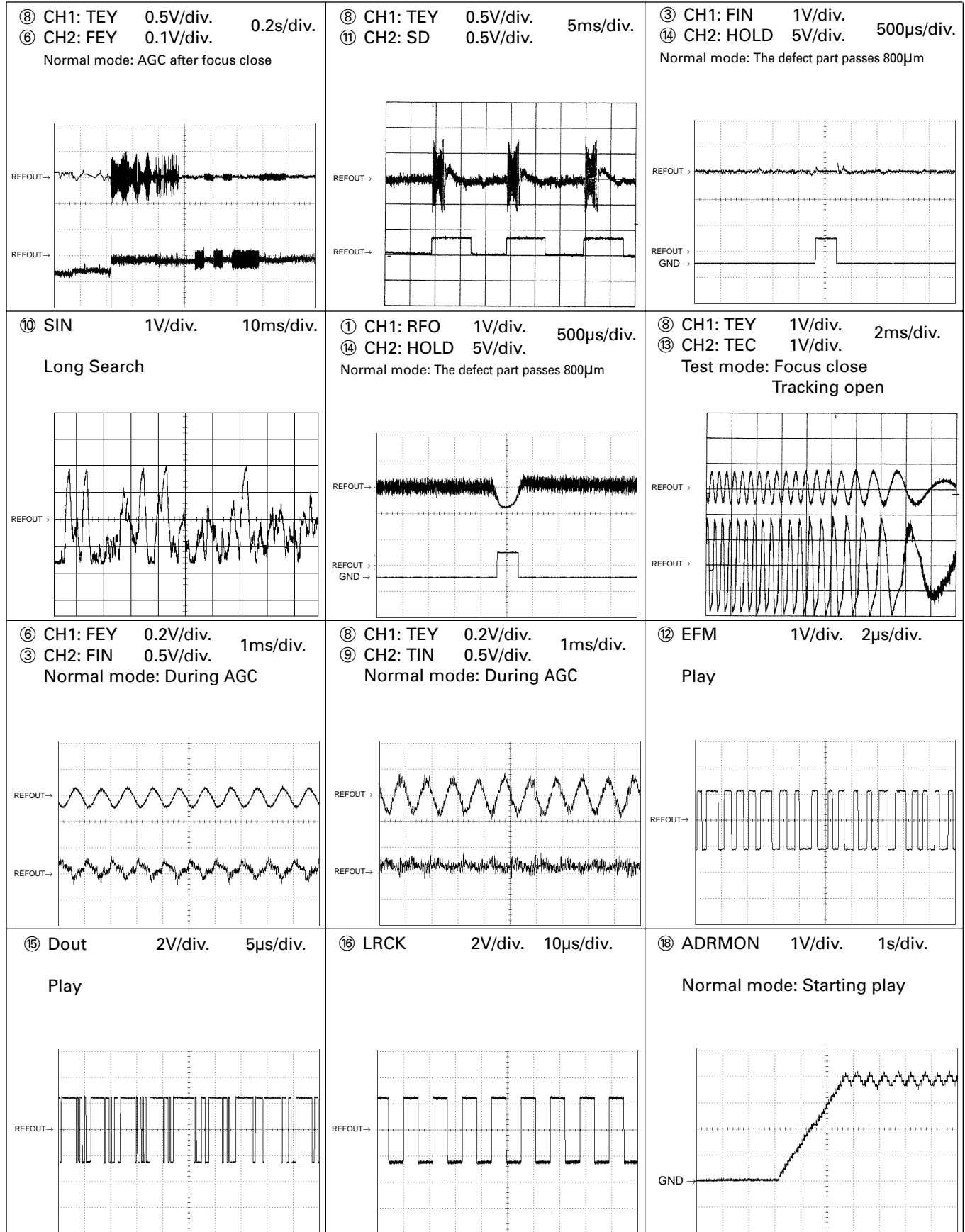

⑧ CH1: TEY 0.5V/div. 5ms/div.
 ⑨ CH2: TIN 0.5V/div.
 Test mode: 100 tracks jump(FWD)

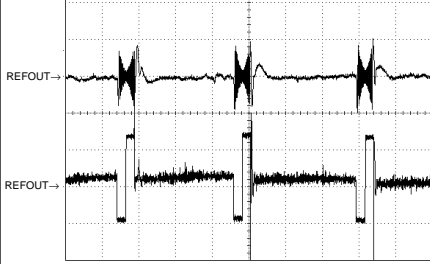

⑧ CH1: TEY 0.5V/div. 10ms/div.
 ⑨ CH2: TIN 0.5V/div.
 Normal mode: Play

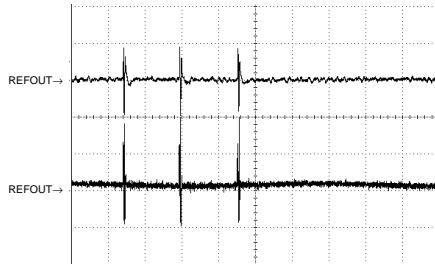

⑰ SCKO 2V/div. 500ns/div.
 Play

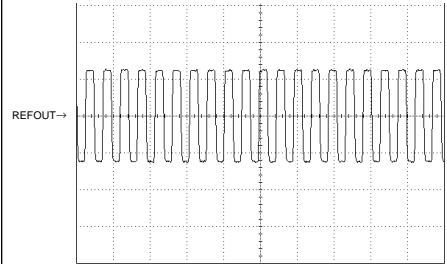

⑳ CH1: RCH 2V/div. 200μs/div.
 ⑲ CH2: LCH 2V/div.
 Normal mode: PLAY (0dB,1kHz)

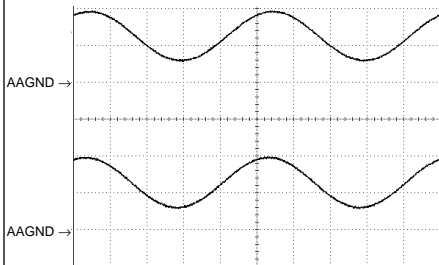

3.7 PCB UNIT(A,B,C,D,E), LOAD MOTOR PCB

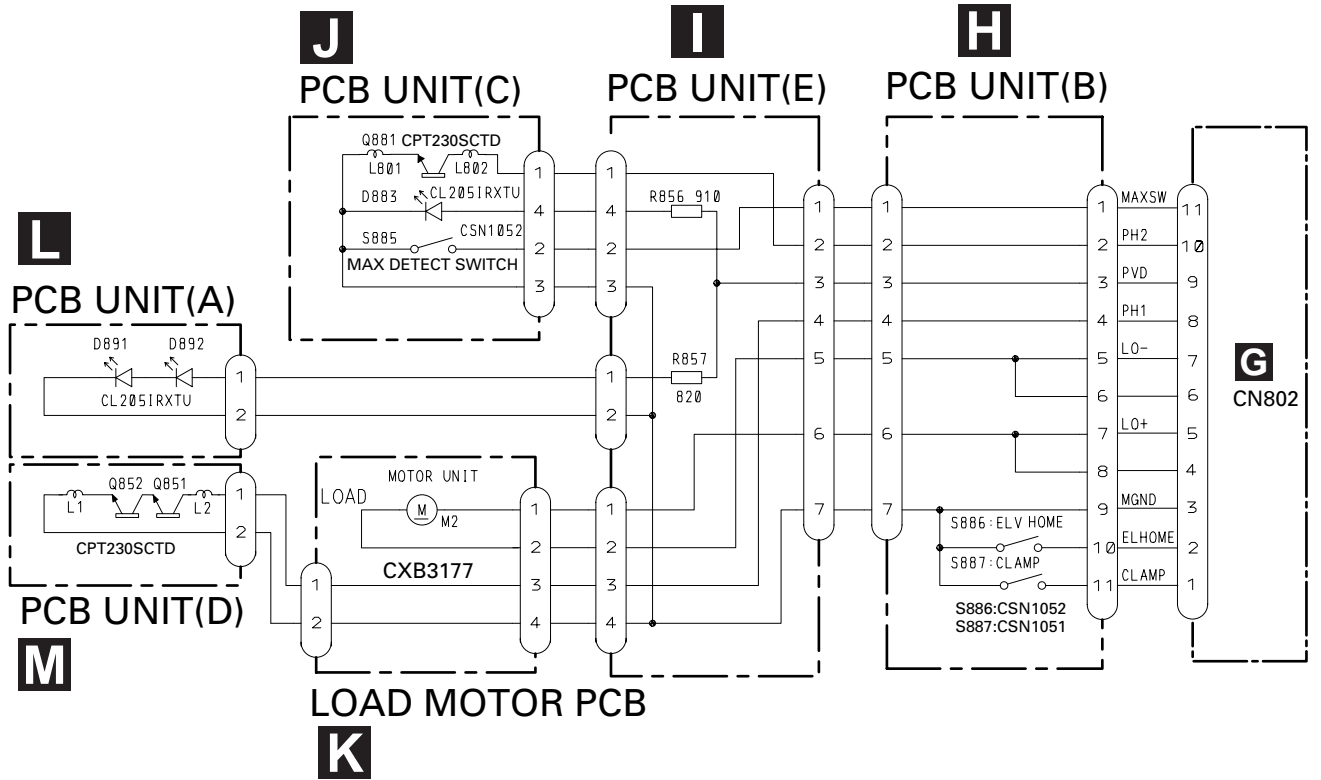

3.8 CASSETTE MECHANISM MODULE

N DECK UNIT

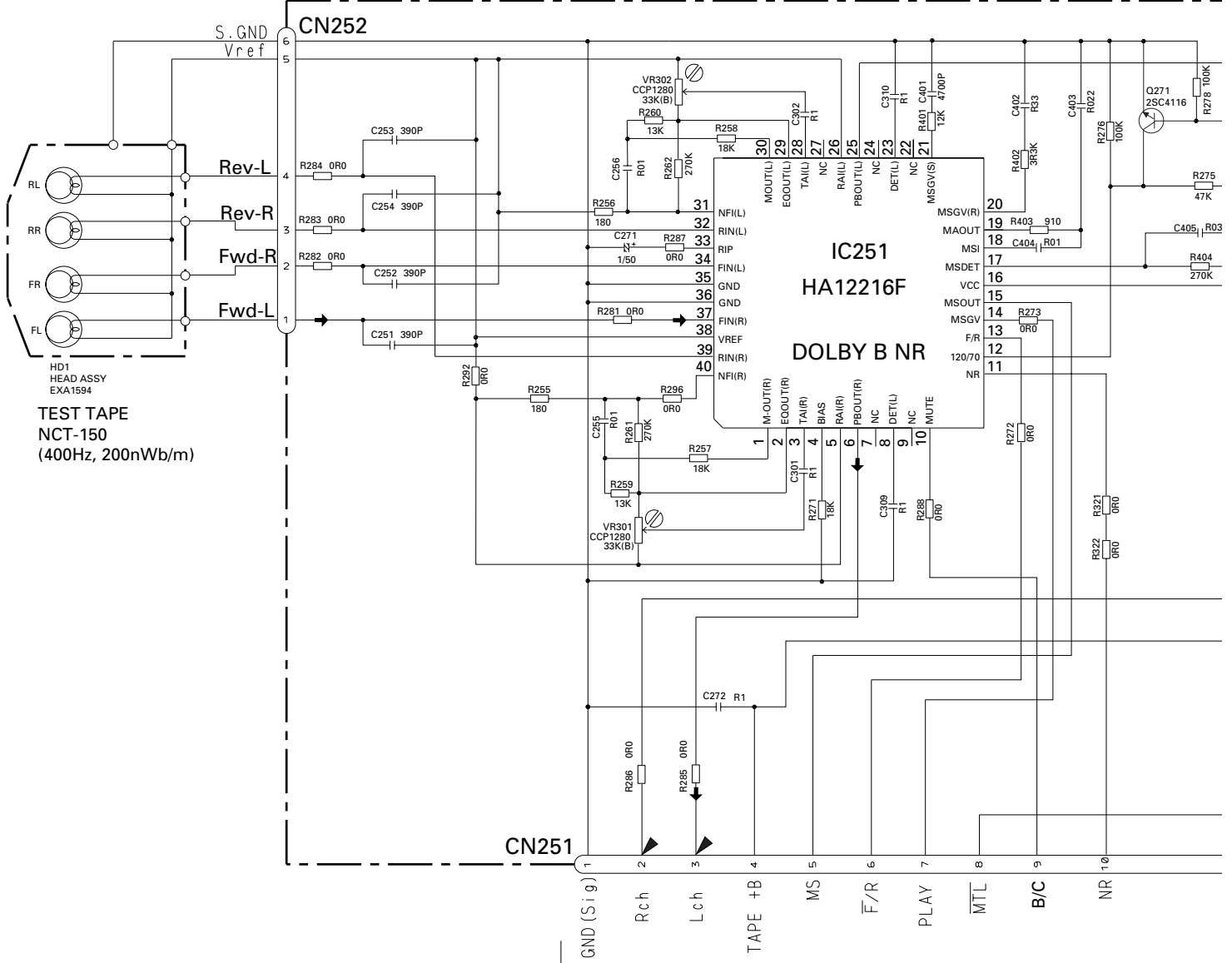

-8.24dBs(300mV)±1dB

A CN301

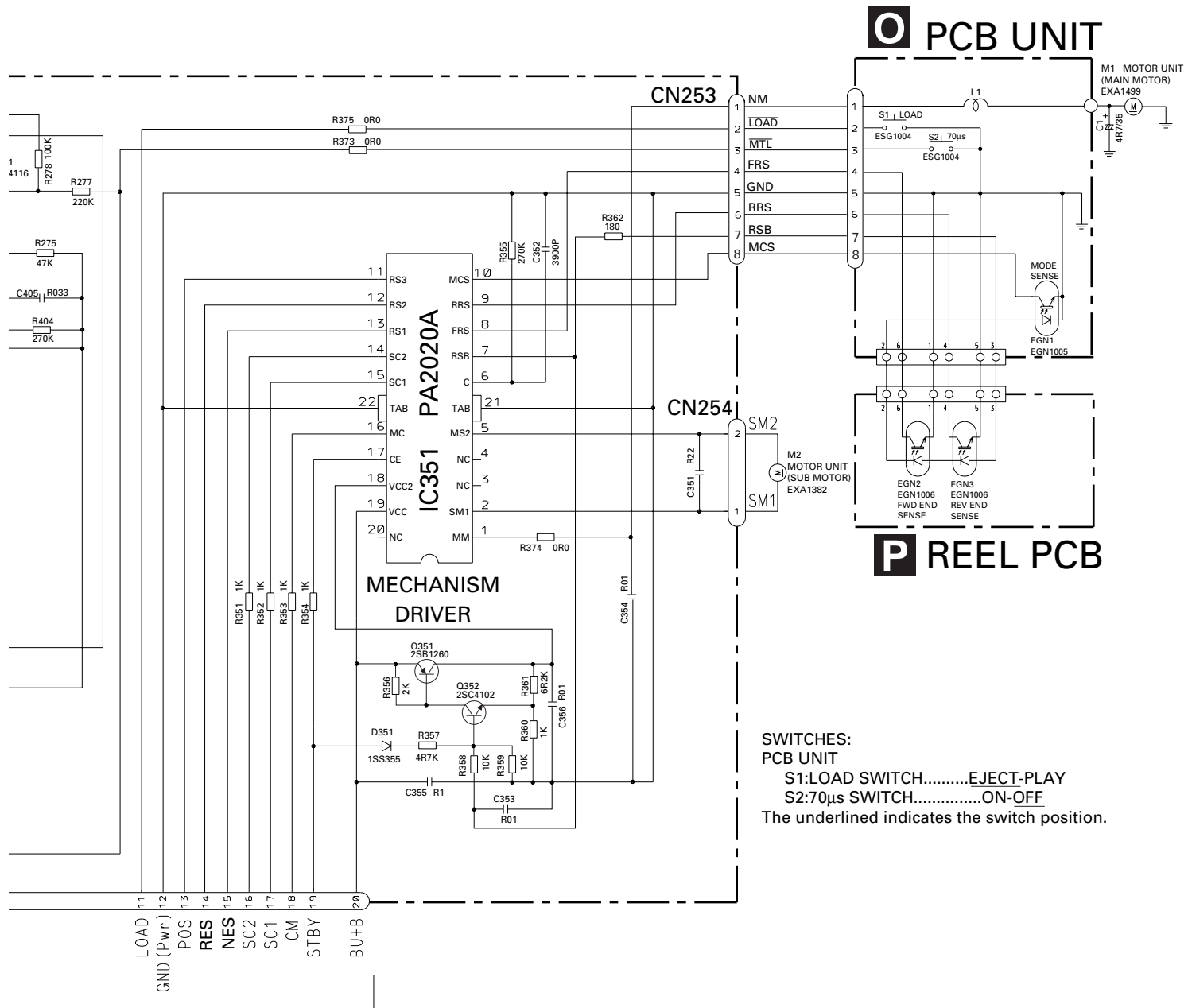

3.9 CONTROL UNIT

Q CONTROL UNIT

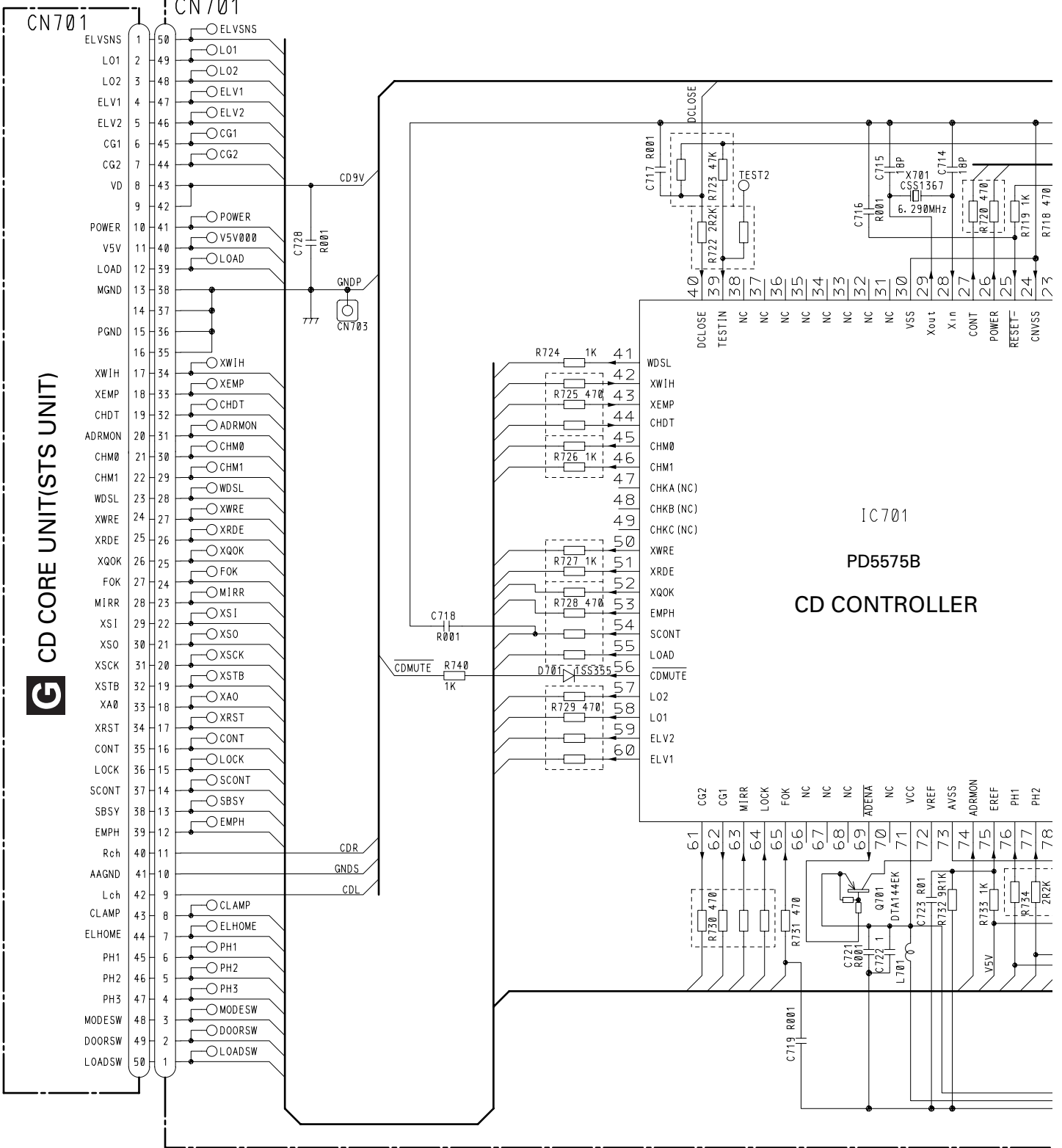

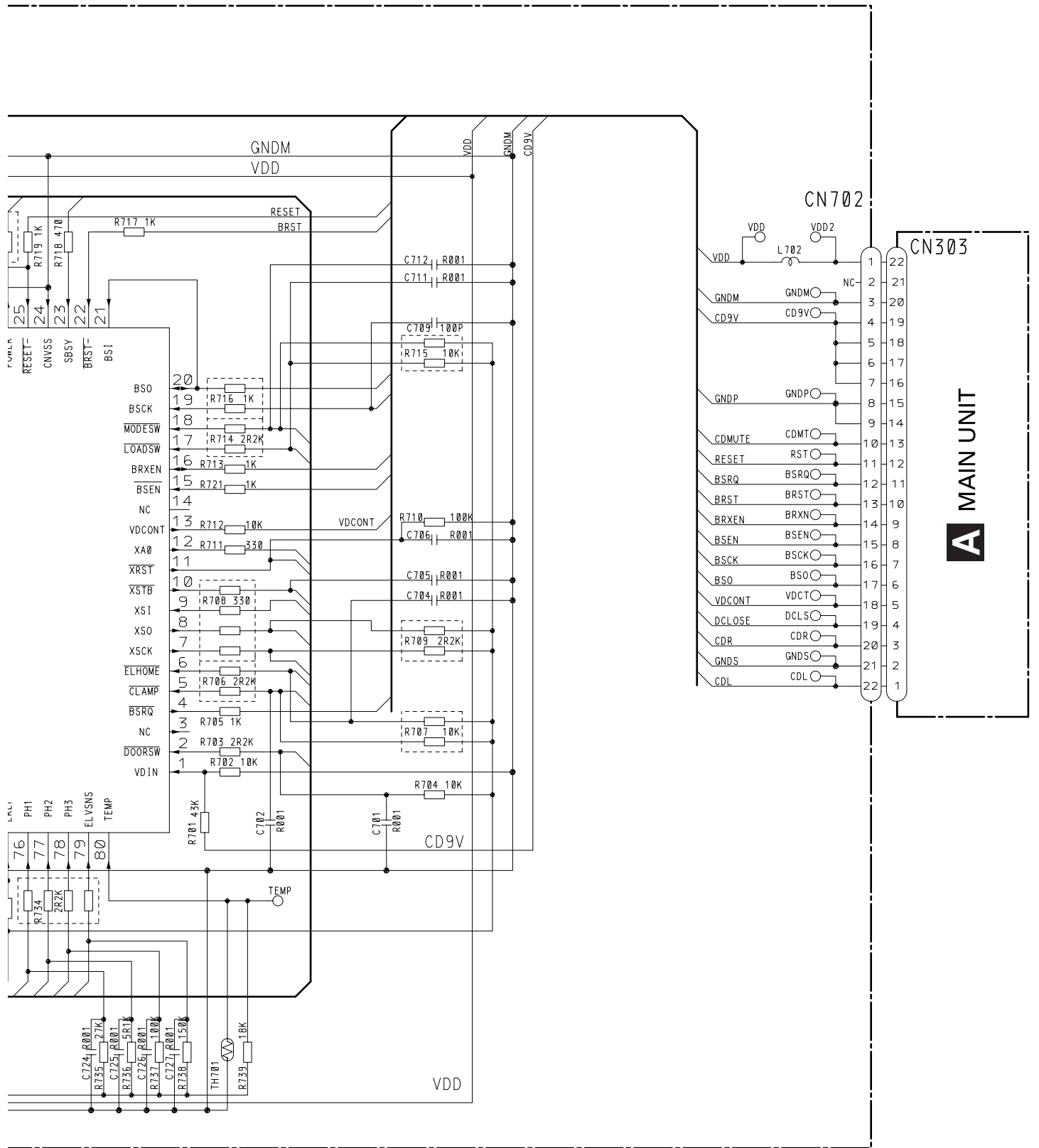

A
B
C
D

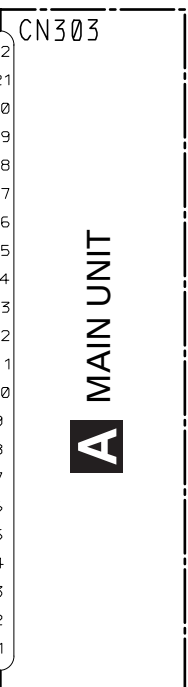

4. PCB CONNECTION DIAGRAM

4.1 MAIN UNIT

NOTE FOR PCB DIAGRAMS

1. The parts mounted on this PCB include all necessary parts for several destination.
 For further information for respective destinations, be sure to check with the schematic diagram.

2. Viewpoint of PCB diagrams

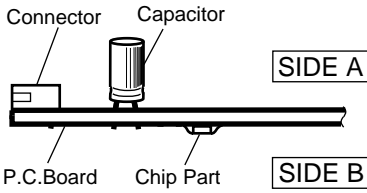

A MAIN UNIT

Q810	Q809	IC, Q	ADJ
Q817	Q815		
Q811	Q811		
Q821	Q821		
Q891	Q892		
Q816	Q805		
Q806	Q806		
Q812	Q894		
Q893	Q893		
Q807	Q807		
Q505	IC501		
Q819	Q819		
Q820	Q825	Q506	
Q804	Q501	Q504	
		Q305	
		Q507	
Q801	IC451		
Q308	IC301		
	Q818		
IC305	Q303		
IC302	IC303		
	IC201		
Q808	Q802		
Q304	Q451		
	Q301		
	Q830		
Q607	Q607		
Q307	Q601	Q861	
Q251	Q862	Q863	
Q605	Q823	Q405	
IC602	Q831	IC251	
	Q829	Q864	
		Q603	
		Q551	
		Q403	
Q402	IC553		
	IC601		
Q822	Q401		
IC604	IC252		
	Q406		
IC603	IC603		
Q503	Q503		
Q606	Q606		

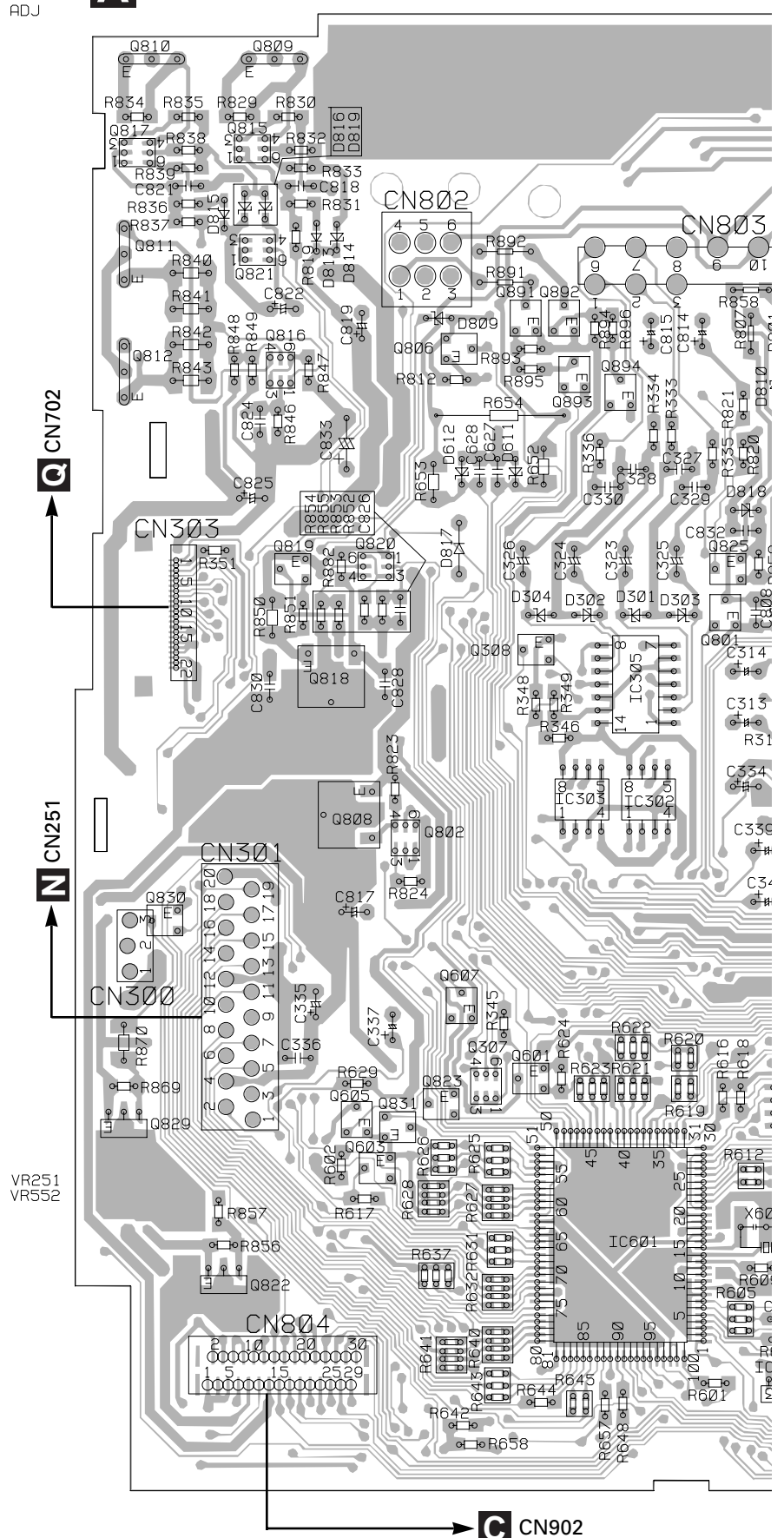

SIDE A

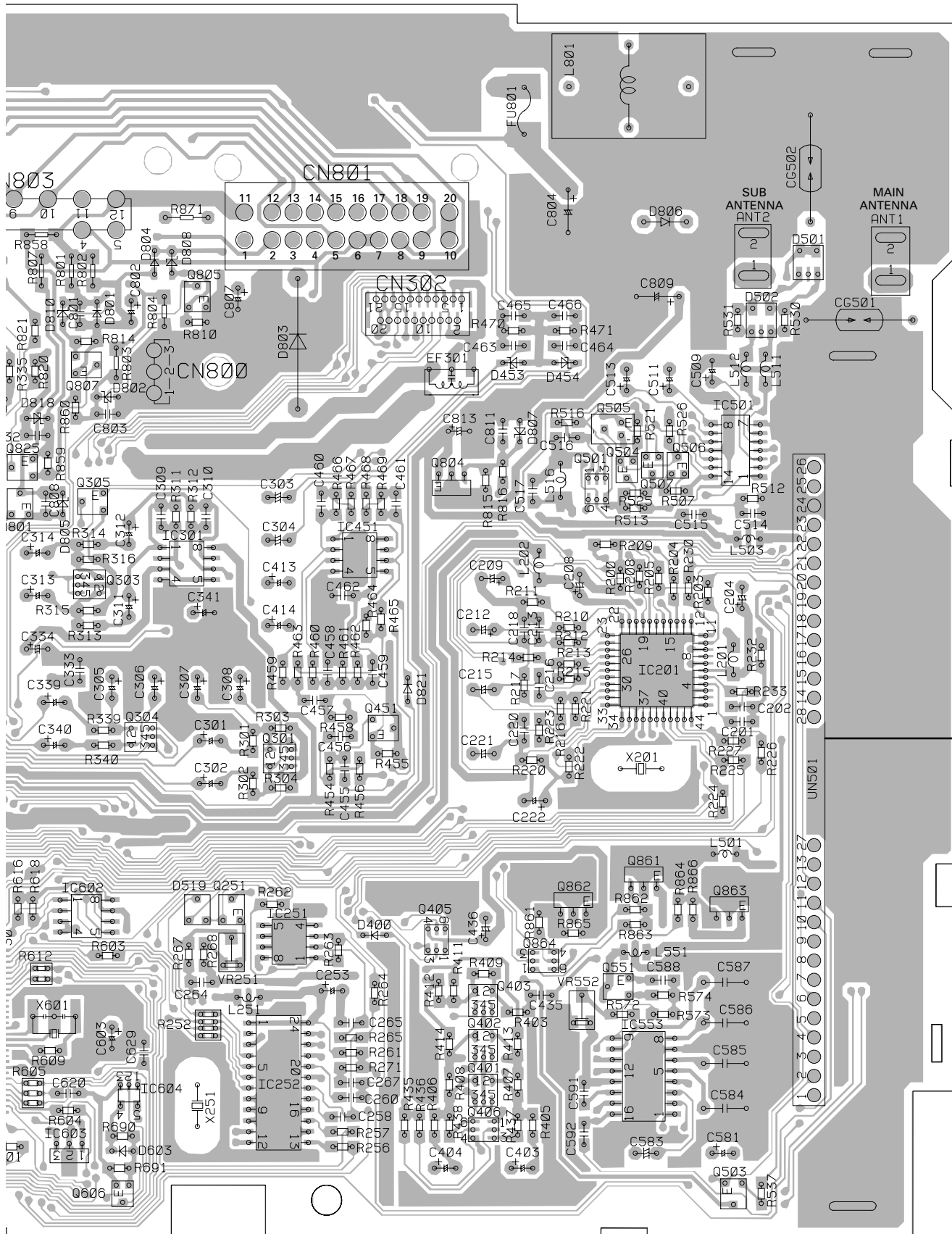

FRONT

A

SIDE B

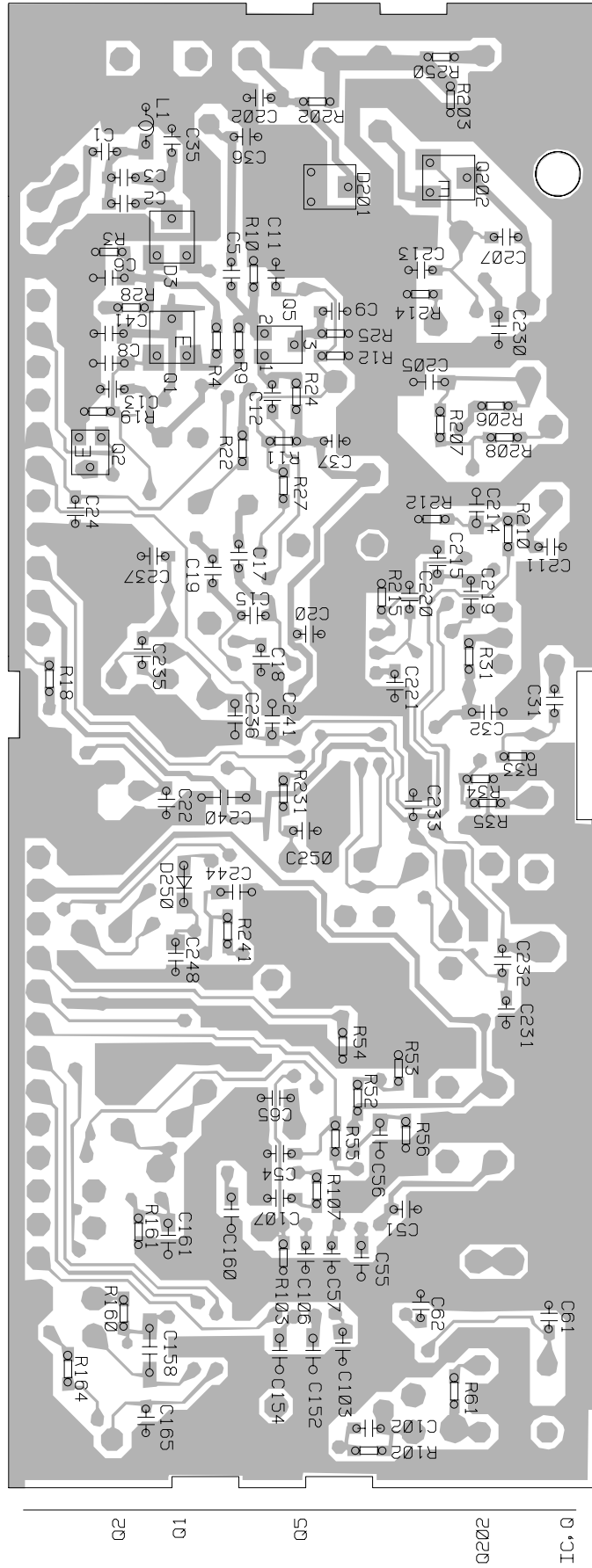

B FM/AM TUNER UNIT

4.3 KEYBOARD UNIT

SIDE A

C KEYBOARD UNIT

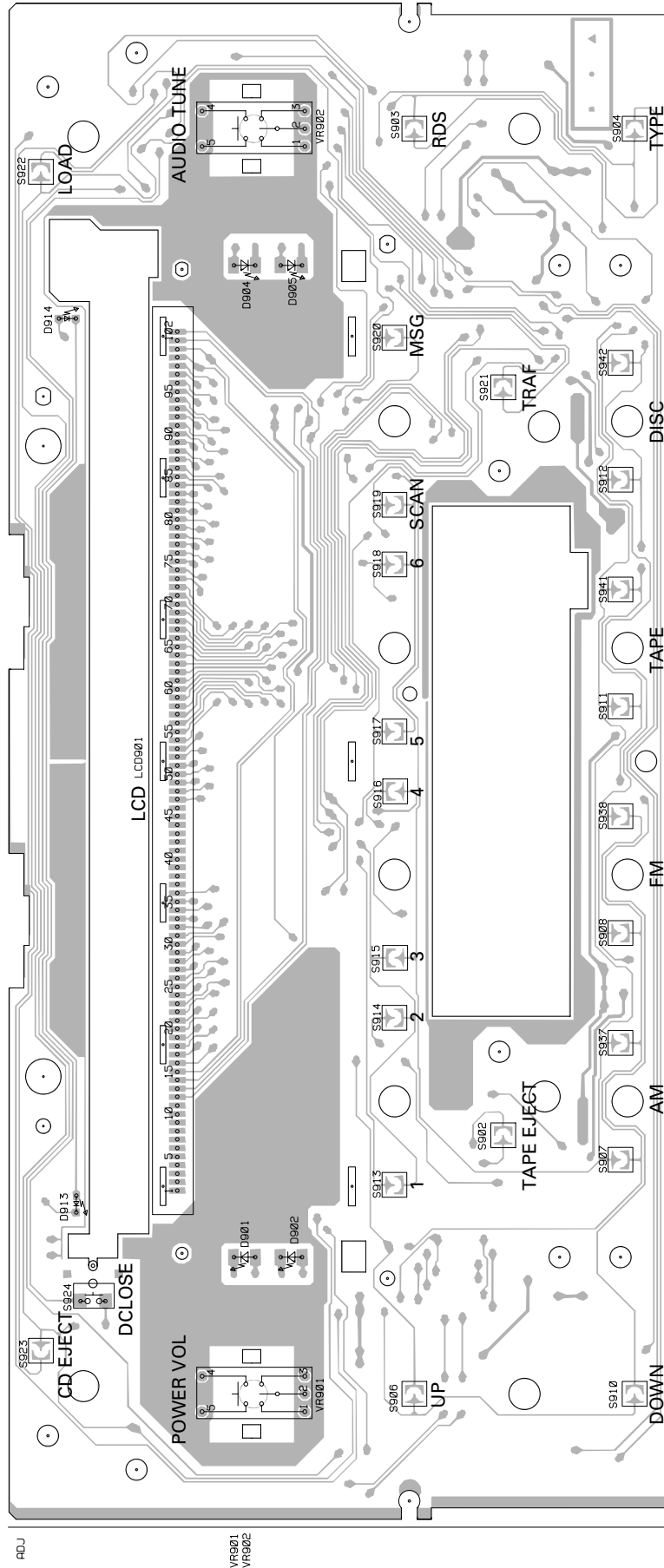

A

B

C

D



SIDE B

A CN804

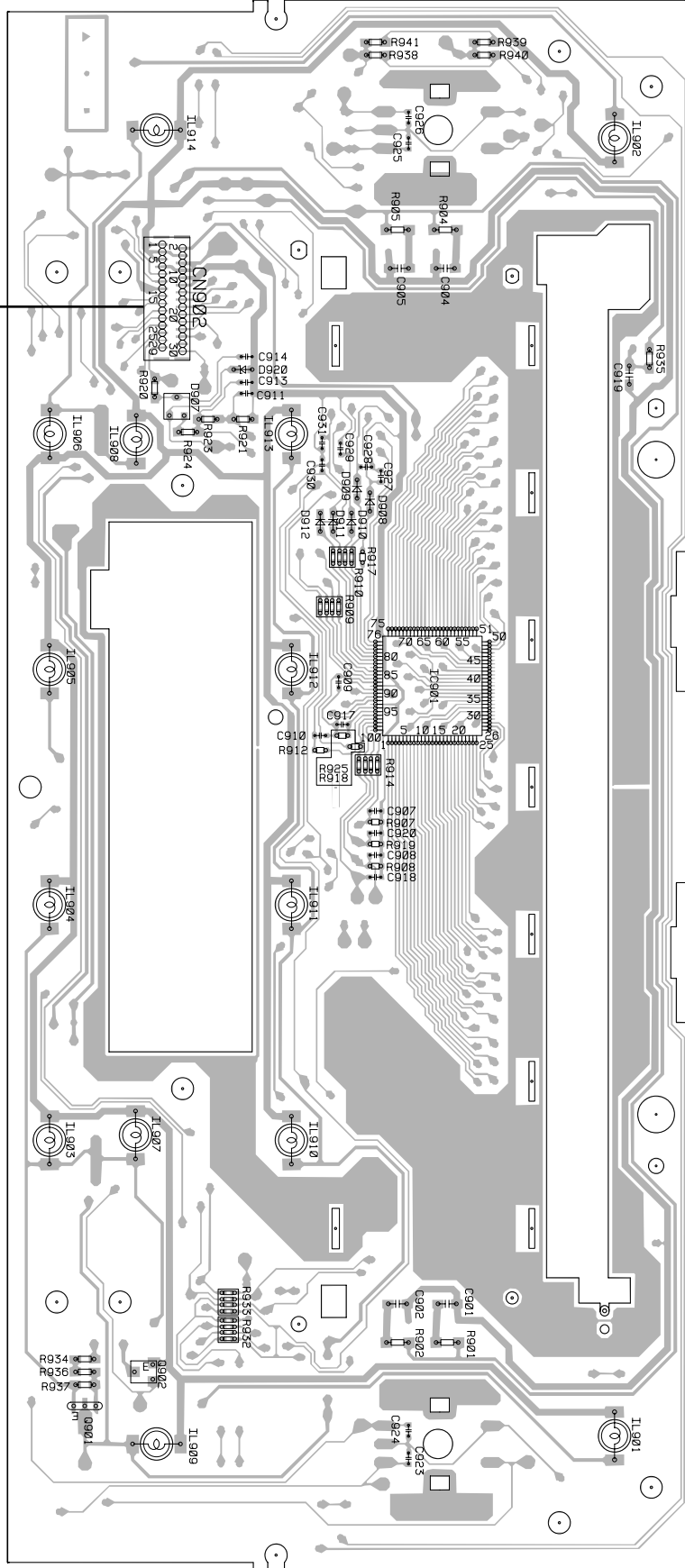

KEYBOARD UNIT



IC 0
IC901
C902
C901



4.4 CD CORE UNIT(SERVO UNIT)

SIDE A

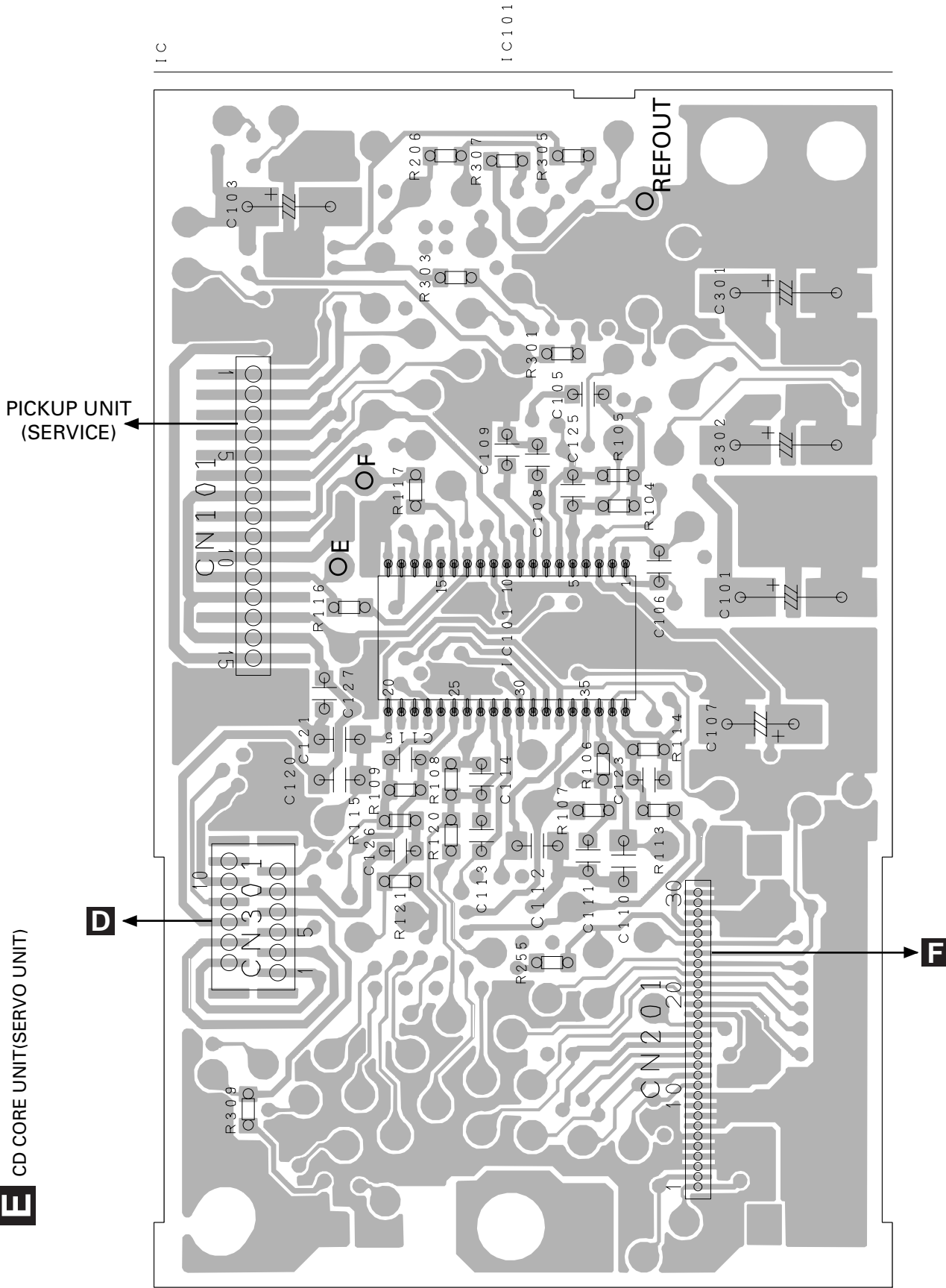

SIDE B

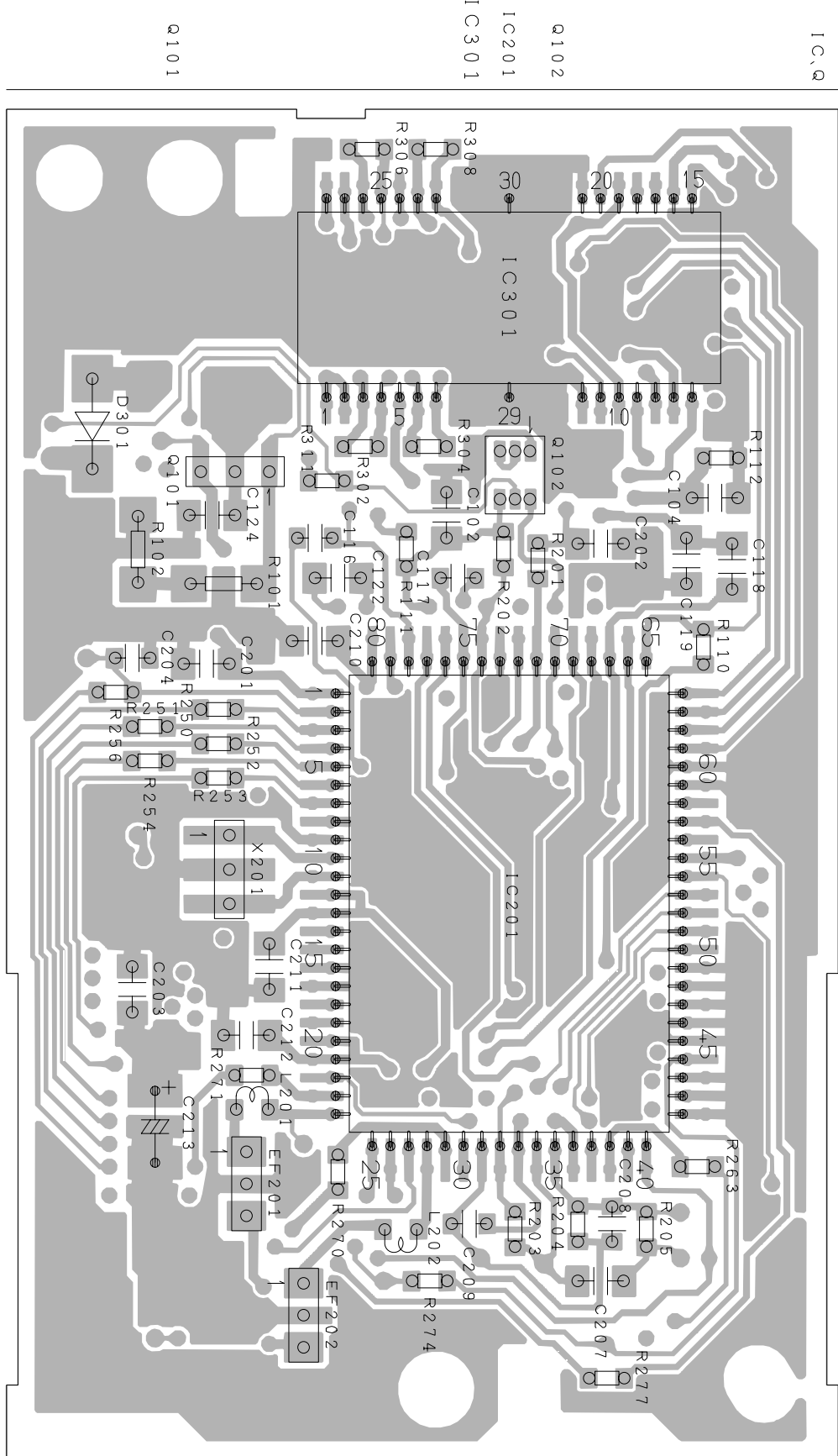

CD CORE UNIT(SERVO UNIT)



1 2 3 4

FX-MG8217ZT, MG8217ZT-91

4.5 CD CORE UNIT (STS UNIT)

G CD CORE UNIT (STS UNIT)

SIDE A

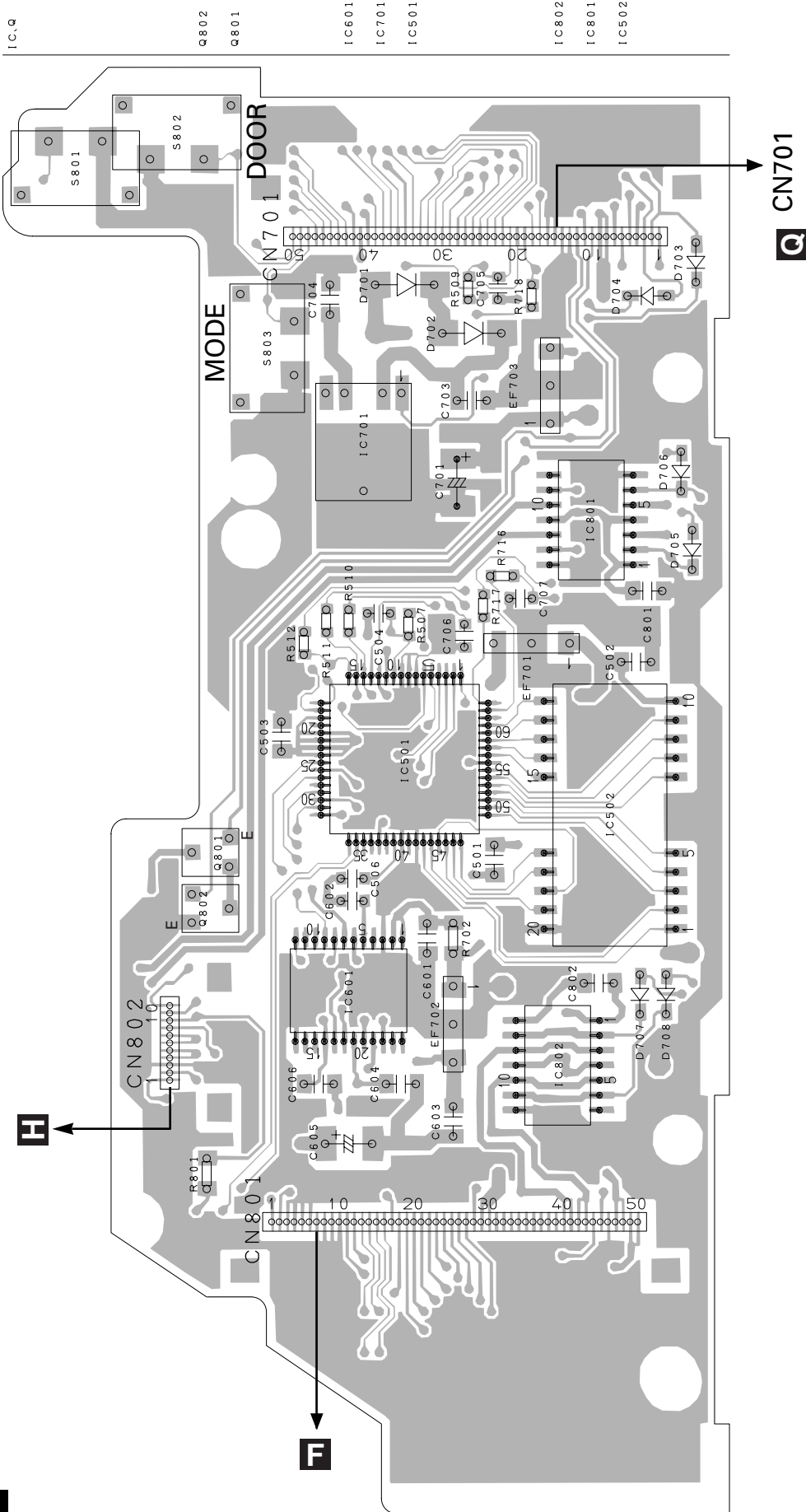

G CD CORE UNIT(STS UNIT)

SIDE B

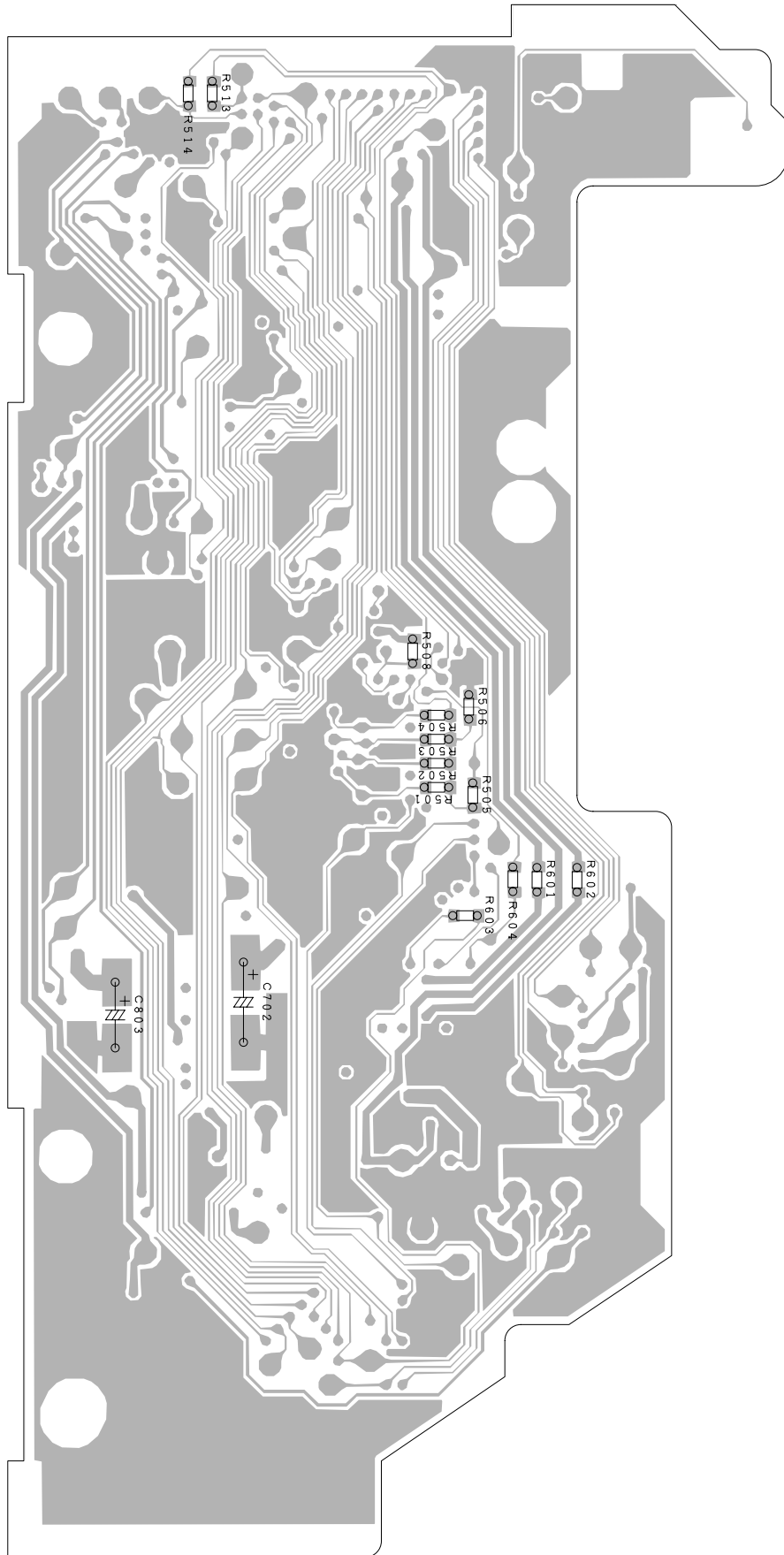

A
B
C
D

4.6 MOTOR PCB(A)

SIDE A

F MOTOR PCB(A)

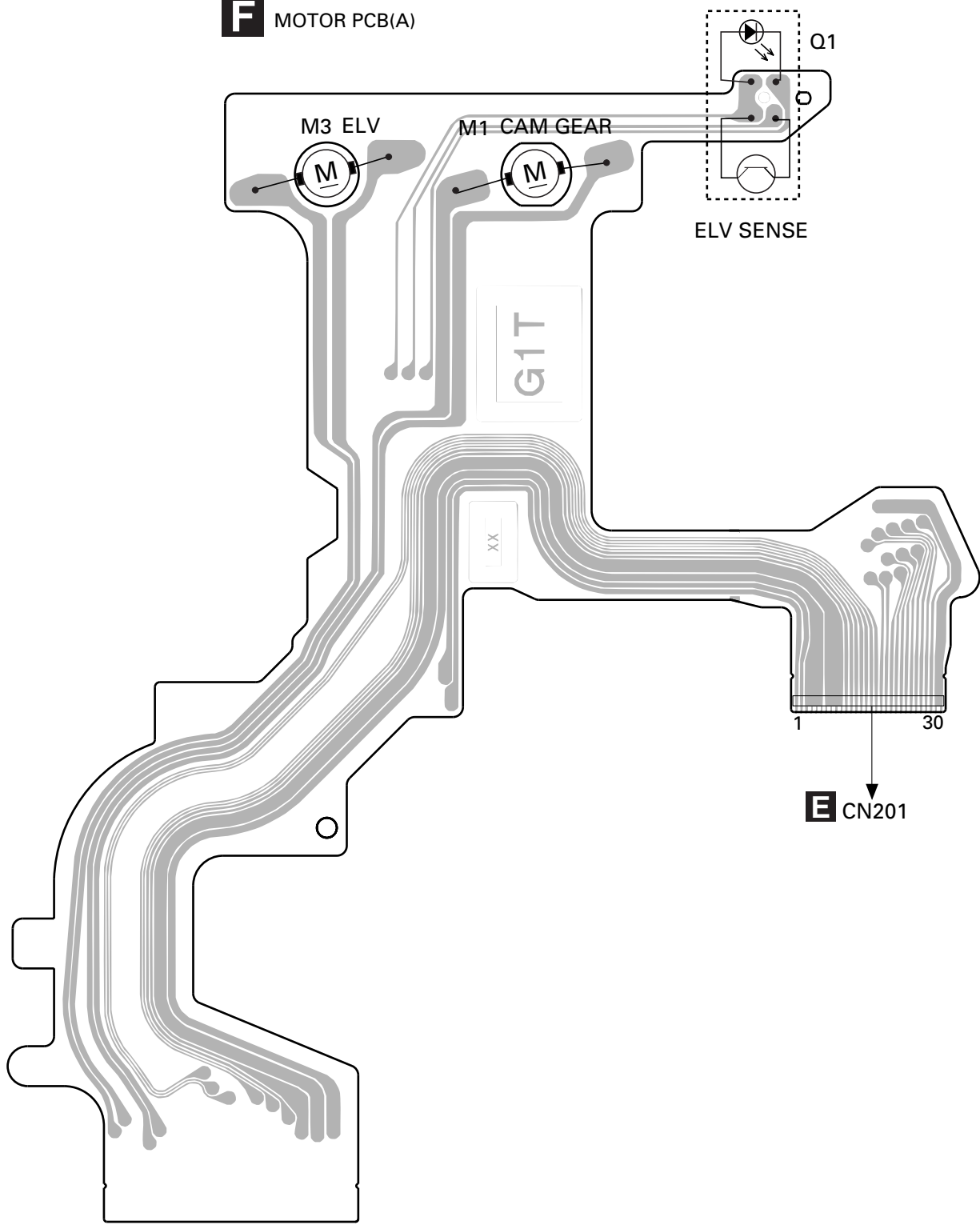

F MOTOR PCB(A)

SIDE B

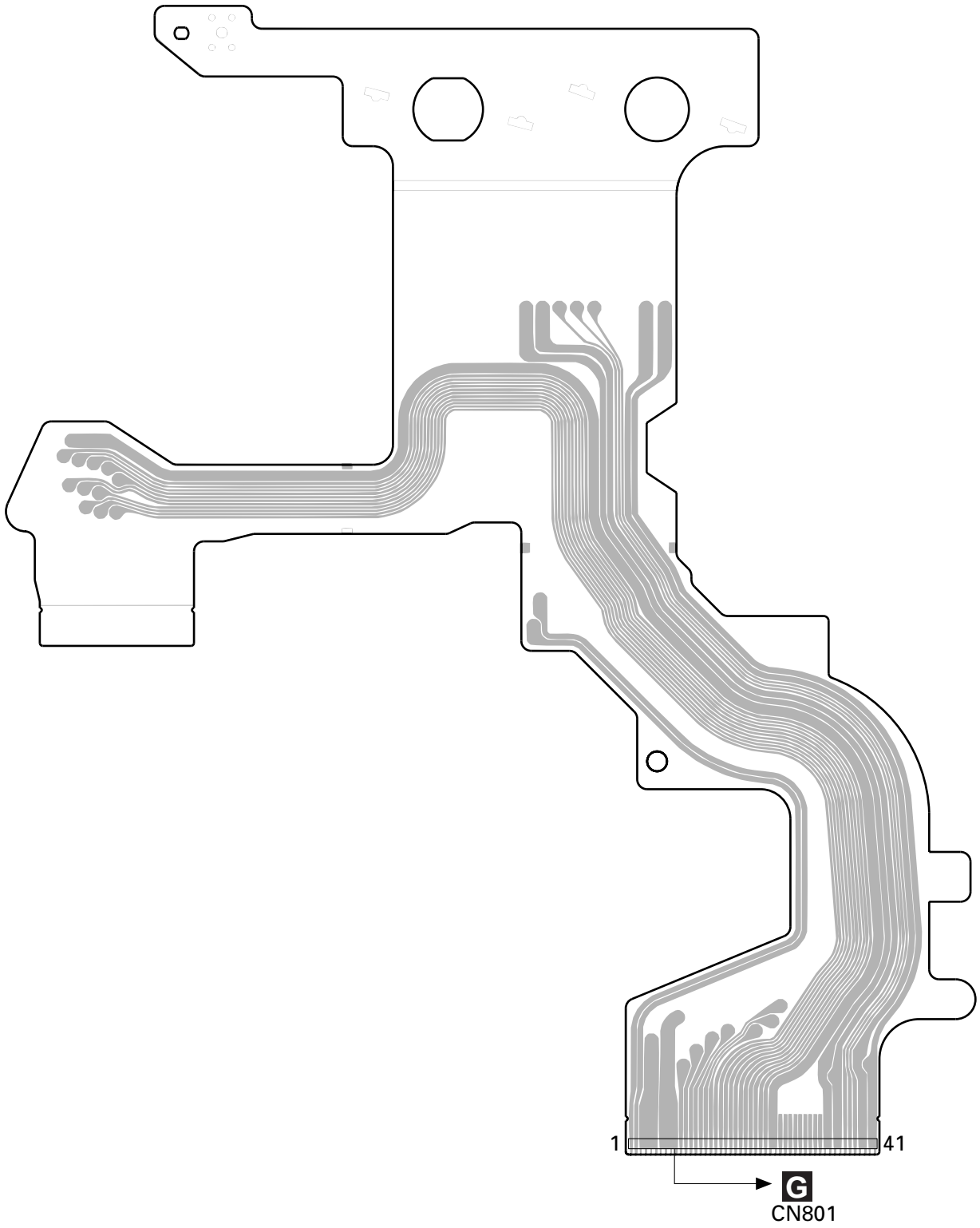

4.7 MOTOR PCB(B)

D MOTOR PCB(B)

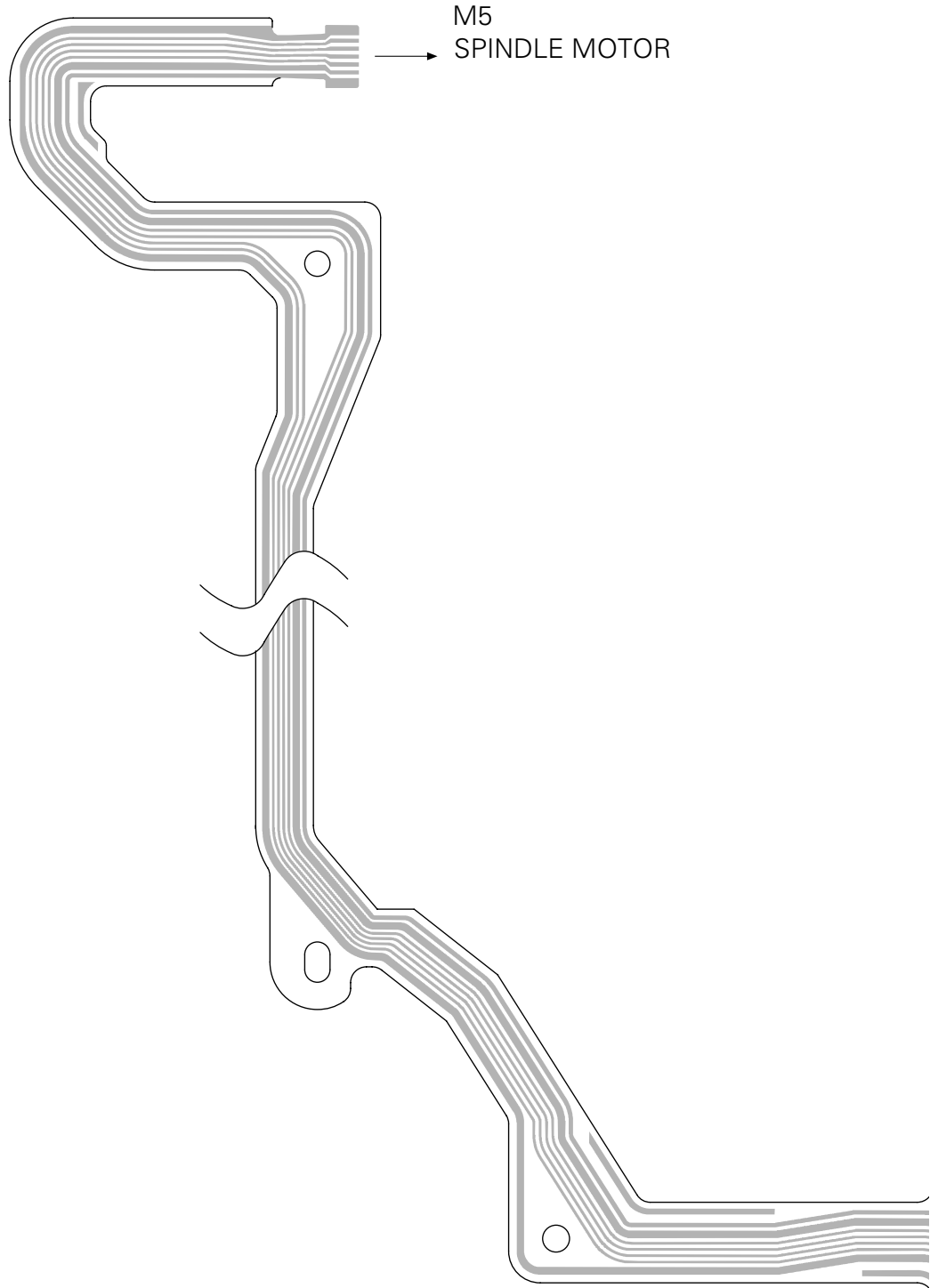

M5
SPINDLE MOTOR

A

B

C

D

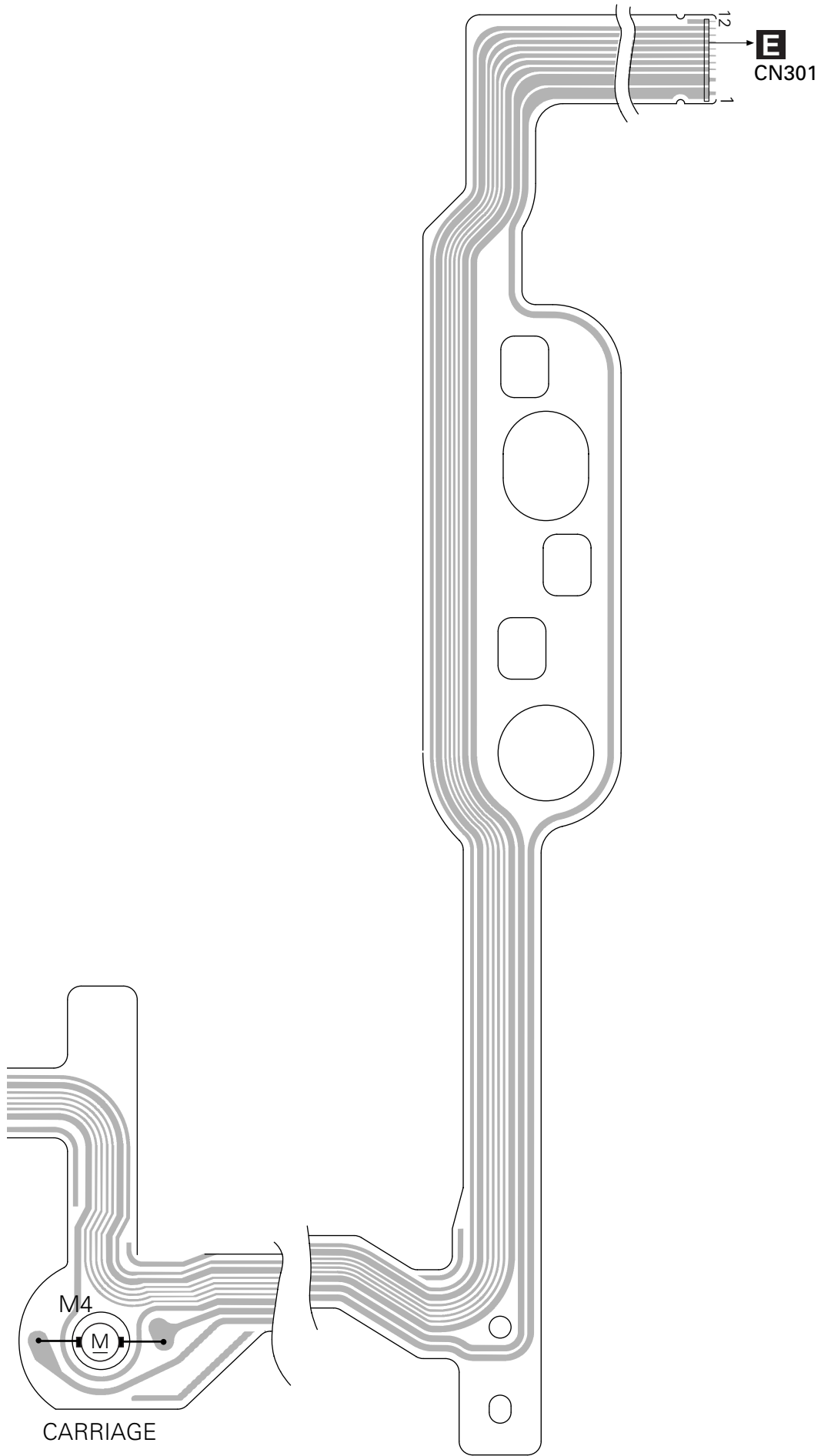

A

B

C

D

4.8 PCB UNIT(B)

4.8 PCB UNIT(D)

A

G
CN802

11
1

H PCB UNIT(B)

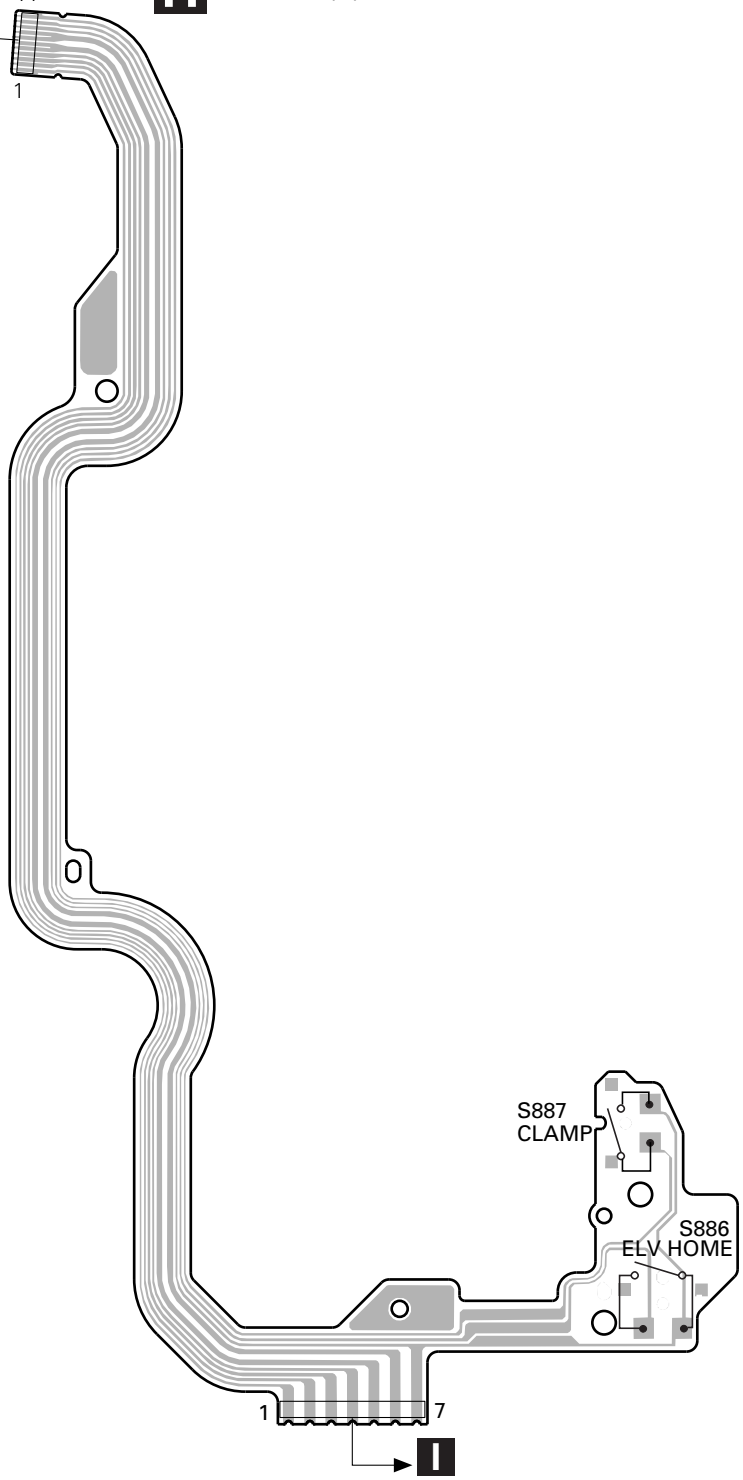

B

C

D

M PCB UNIT(D)

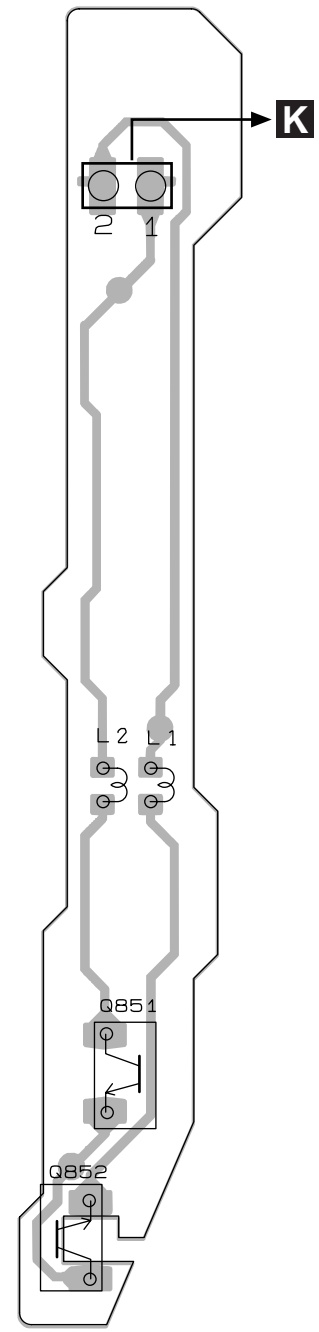

4.10 PCB UNIT(C)

J PCB UNIT(C)

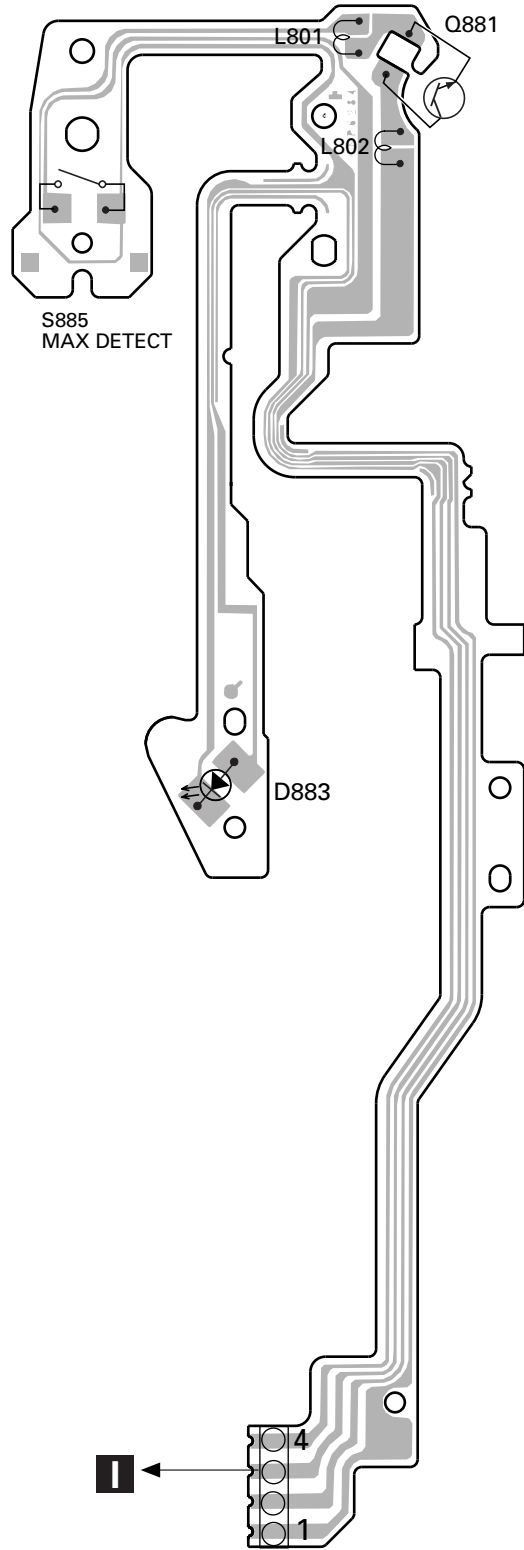

A

B

C

D

4.11 LOAD MOTOR PCB

A

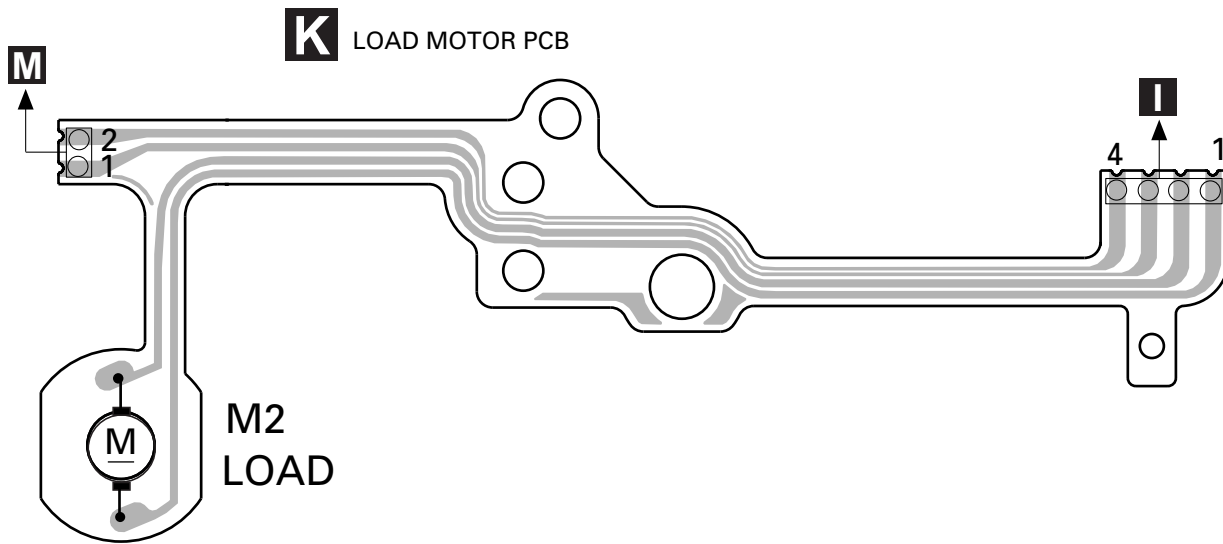

B

4.12 PCB UNIT(A)

C

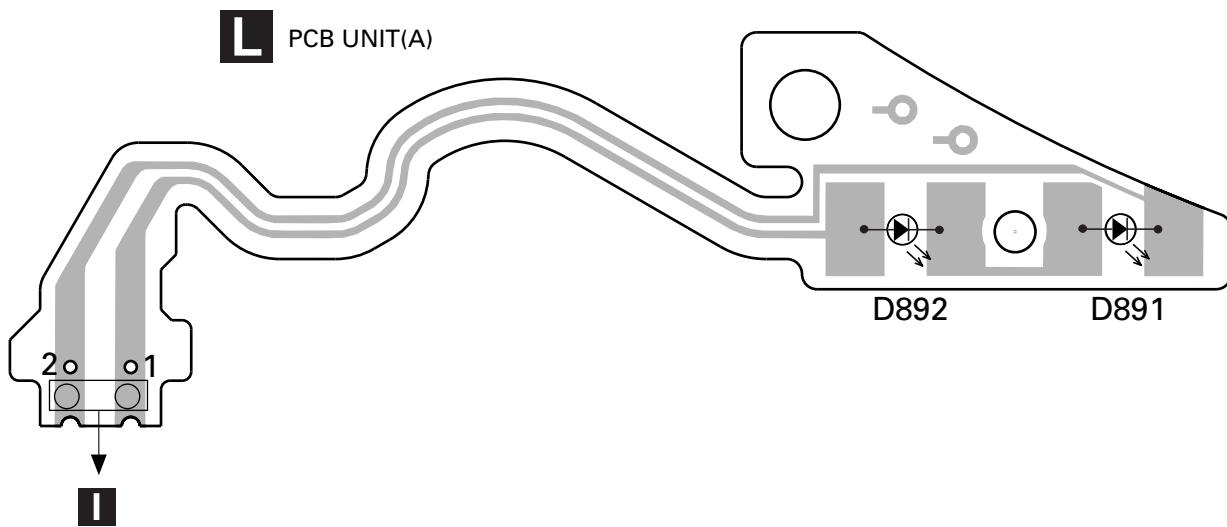

D

4.13 PCB UNIT(E)

I PCB UNIT(E)

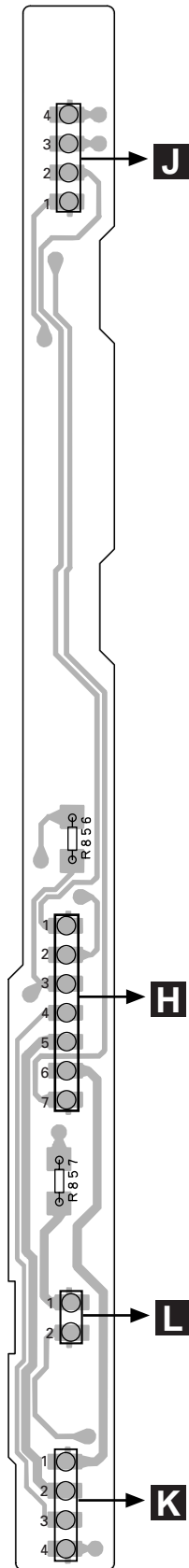

SIDE A

I PCB UNIT(E)

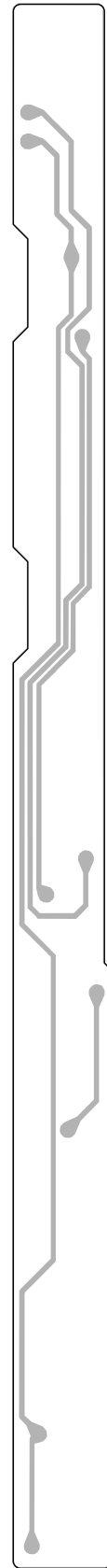

SIDE B

A
B
C
D

4.14 DECK UNIT

N DECK UNIT

A CN301

SIDE A

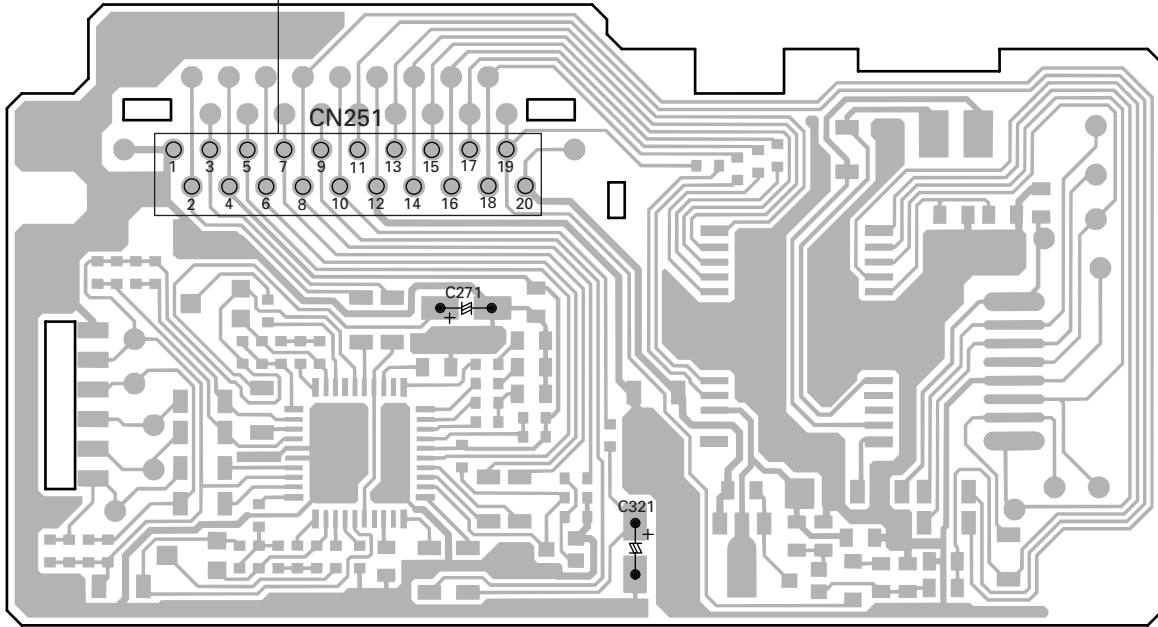

N DECK UNIT

SIDE B

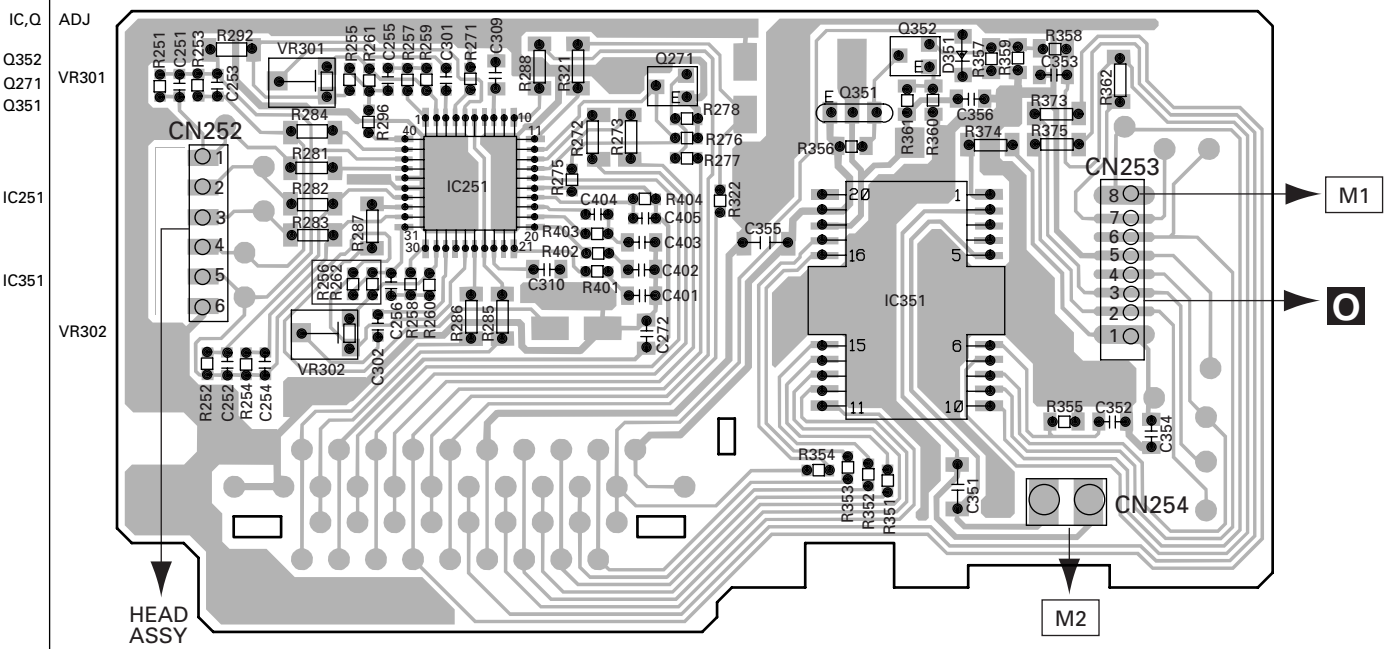

4.15 PCB UNIT

O PCB UNIT

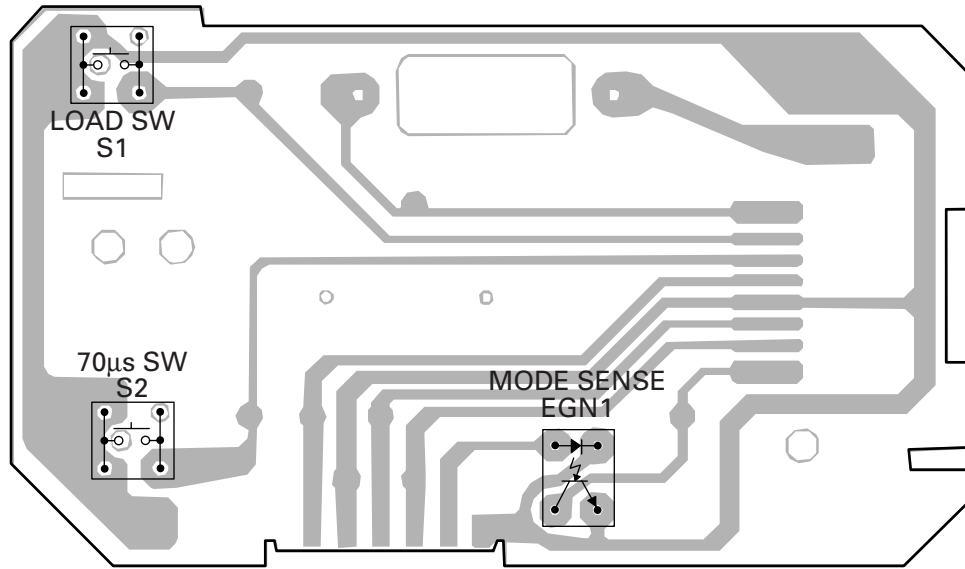

SIDE A

O PCB UNIT

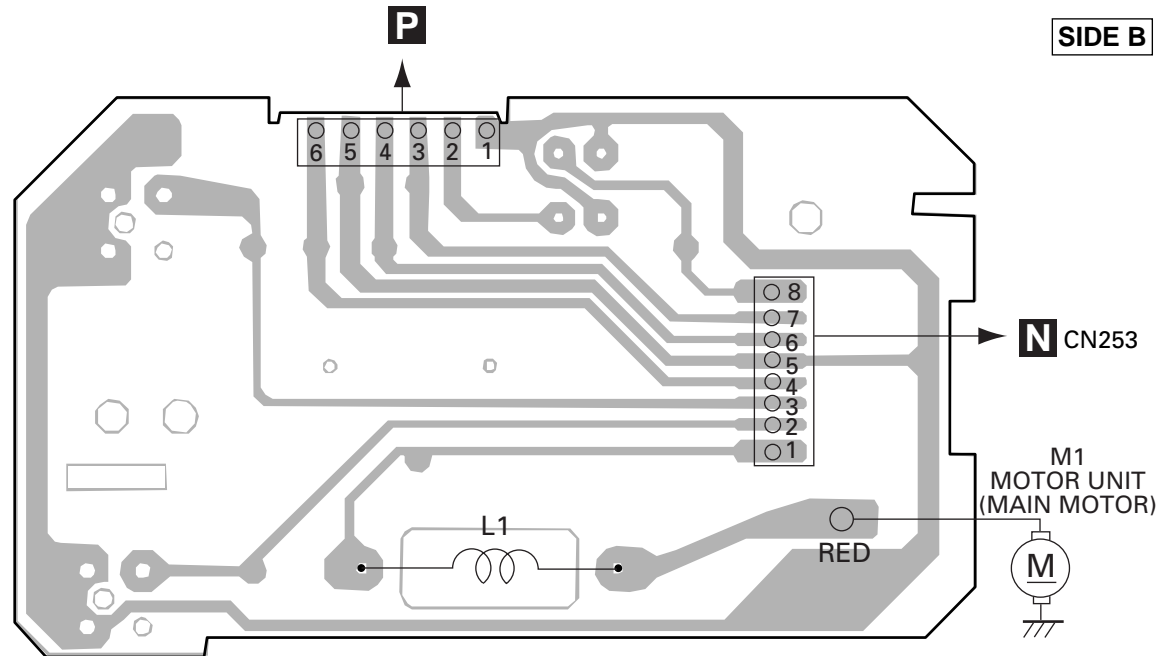

SIDE B

4.16 REEL PCB

P REEL PCB

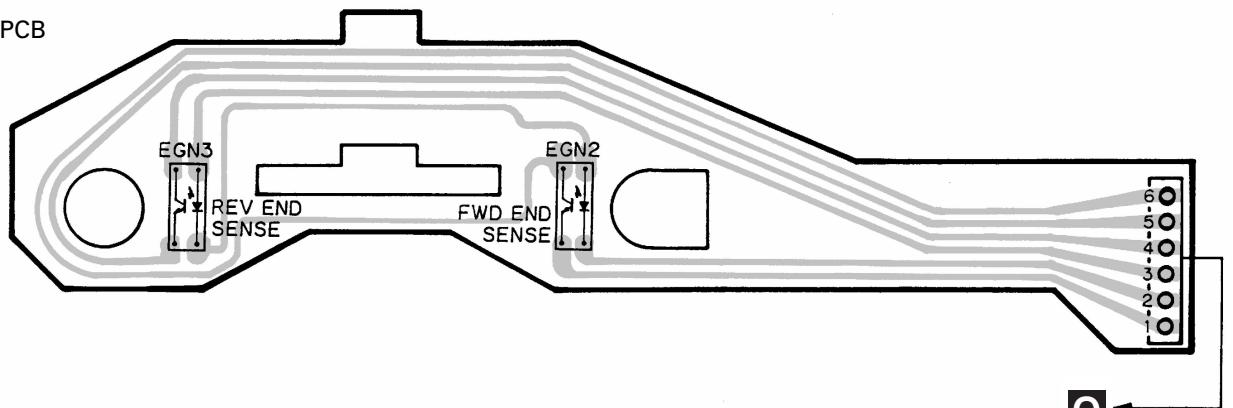

4.17 CONTROL UNIT

SIDE A

A

B

C

D

Q CONTROL UNIT

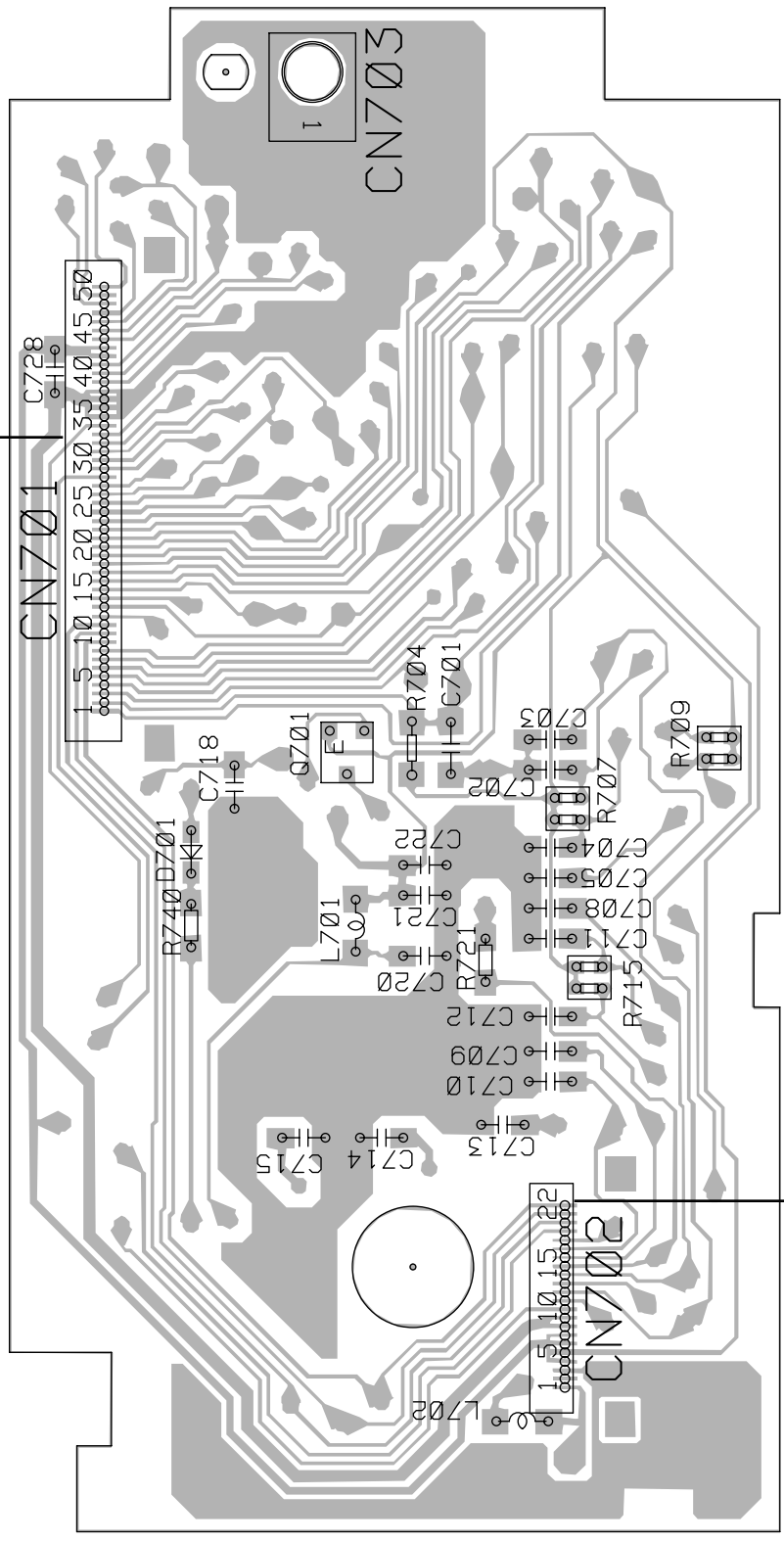

G CN701

A CN303

SIDE B

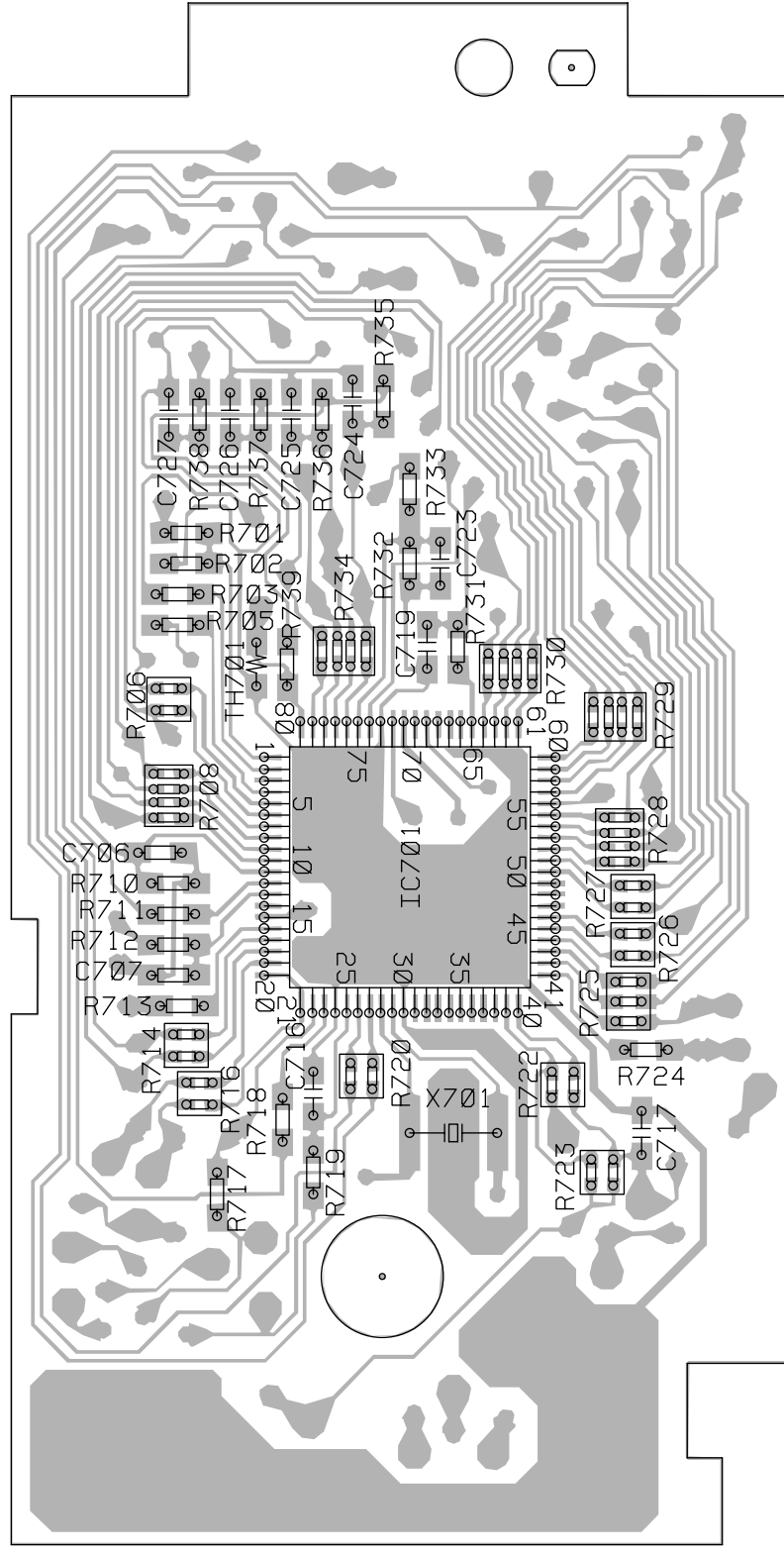

Q CONTROL UNIT

IC, Q

IC701

Q

Q

5. ELECTRICAL PARTS LIST

NOTES:

- Parts whose parts numbers are omitted are subject to being not supplied.
- The part numbers shown below indicate chip components.

Chip Resistor

RS1/OSOOOJ, RS1/OOSOOOJ

Chip Capacitor (except for CQS.....)

CKS....., CCS....., CSZS.....

====Circuit Symbol and No.====Part Name Part No. =====Circuit Symbol and No.====Part Name Part No.

B Unit Number : CWE1543
Unit Name : FM/AM Tuner Unit

MISCELLANEOUS

IC	1	IC	PA4026A
IC	2	IC	PA4024A
Q	1	Chip Transistor	2SC2712
Q	3	FET	3SK263
Q	5	Transistor	2SK1067
Q	31	Chip Transistor	2SC2712
Q	151	Transistor	DTC144EU
Q	165	Transistor	2SC4116
Q	201	FET	2SK291
Q	202	Chip Transistor	2SC2712
Q	203	FET	2SK2373
D	3	Diode	1SV251
D	4	Diode	1SV250
D	5	Diode	KV1410-F1
D	6	Diode	MA157
D	7	Diode	KV1410-F1
D	8	Diode	KV1410-F1
D	9	Diode	KV1410-F1
D	10	Diode	1SV250
D	201	Diode	MA157
D	202	Diode	1SV251
D	231	Diode	SVC253
L	1	Inductor	LCTBR12K2125
L	2	Air-core Coil	CTC1152
L	3	Air-core Coil	CTC1152
L	4	Air-core Coil	CTC1151
L	5	Coil	CTC1147
L	6	Air-core Coil	CTC1153
L	40	Inductor	LCTBR15K1608
L	51	Ferri-Inductor	LAU150K
L	52	Coil	CTC1136
L	201	Ferri-Inductor	LAU4R7K
L	202	Ferri-Inductor	LAU330K
L	203	Inductor	CTF1371
L	208	Inductor	LAU390K
L	209	Inductor	LCTA680J3225
L	210	Coil	CTB1103
L	231	Inductor	LAU3R3J
T	31	Coil	CTE1116
TC	1	Trimmer	CCL1019
TC	2	Trimmer	CCL1019
TC	3	Trimmer	CCL1019
CF	25	Ceramic Filter	CTF1292
CF	51	Ceramic Filter	CTF1292
CF	52	Ceramic Filter	CTF1292
CF	53	Ceramic Filter	CTF1292
CF	230	Crystal Filter	CTF1262
CF	232	Ceramic Filter	CTF1348
X	151	Radiator 918.5Hz	CSS1365
X	231	Crystal Resonator 10.26MHz	CSS1111

RESISTORS

VR	101	Semi-fixed 15kΩ(B)	CCP1230
VR	151	Semi-fixed 10kΩ(B)	CCP1229
VR	154	Semi-fixed 150kΩ(B)	CCP1236
VR	156	Semi-fixed 100kΩ(B)	CCP1235
R	3		RS1/16S223J
R	4		RS1/16S101J
R	6		RS1/16S101J
R	8		RS1/16S332J
R	9		RS1/16S823J
R	10		RS1/16S223J
R	11		RS1/16S124J
R	12		RS1/16S474J
R	15		RS1/16S161J
R	16		RS1/16S104J
R	17		RS1/16S332J
R	18		RS1/16S332J
R	19		RS1/16S154J
R	21		RS1/16S332J
R	22		RS1/16S510J
R	24		RS1/16S101J
R	25		RS1/16S221J
R	26		RS1/16S102J
R	31		RS1/16S470J
R	32		RS1/16S912J
R	33		RS1/16S912J
R	34		RS1/16S331J
R	35		RS1/16S331J
R	51		RS1/16S331J
R	55		RS1/16S102J
R	56		RS1/16S823J
R	61		RS1/16S392J
R	62		RS1/16S273J
R	103		RS1/16S333J
R	104		RS1/16S334J
R	105		RS1/16S683J
R	107		RS1/16S222J
R	152		RS1/16S393J
R	155		RS1/16S393J
R	157		RS1/10S223J
R	160		RS1/16S222J
R	161		RS1/16S563J
R	162		RS1/16S225J
R	163		RS1/16S222J
R	164		RS1/16S823J
R	165		RS1/16S102J
R	201		RS1/16S103J
R	202		RS1/16S103J
R	203		RS1/16S225J
R	204		RS1/16S472J
R	205		RS1/16S471J
R	206		RS1/16S220J
R	207		RS1/16S101J
R	208		RS1/16S102J
R	210		RS1/16S125J

====Circuit Symbol and No.====Part Name	Part No.	====Circuit Symbol and No.====Part Name	Part No.
R 211	RS1/16S223J	C 157	CEAL3R3M50
R 214	RS1/16S393J	C 158	CKSYB474K16
R 215	RS1/16S104J	C 159	CEAL220M6R3
R 230	RS1/16S0R0J	C 160	CKSQYB104K16
R 231	RS1/16S242J	C 161	CKSQYB104K16
R 232	RS1/16S473J	C 162	CEAL3R3M50
R 237	RS1/16S103J	C 163	CKSRYB102K50
R 238	RS1/16S104J	C 165	CCSRCH100D50
R 239	RS1/16S104J	C 201	CKSRYB103K25
R 240	RS1/16S103J	C 202	CCSRCH100D50
R 241	RS1/16S202J	C 203	CKSRYB332K50
R 243	RS1/16S123J	C 204	CKSQYB473K16
R 244	RS1/16S103J	C 205	CKSQYB473K16
R 246	RS1/16S0R0J	C 206	CKSRYB103K25
R 247	RS1/10S303J	C 207	CCSRCH120J50
R 248	RS1/16S0R0J	C 211	CCSRCH560J50
R 250	RS1/16S0R0J	C 212	CEAL680M10
		C 213	CKSRYB103K25
		C 214	CKSQYB225K10
		C 215	CCSRCH680J50
		C 216	CCSRCH101J50
		C 217	CEAL2R2M50
		C 219	CKSRYB223K25
		C 220	CKSRYB103K25
		C 221	CKSRYB103K25
		C 230	CKSQYB104K16
		C 231	CCSRCH330J50
		C 232	CCSRCH150J50
		C 233	CKSRYB103K25
		C 234	CEJA330M10
		C 235	CKSRYB332K50
		C 236	CKSQYB473K16
		C 237	CCSRTH180J50
		C 239	CKSRYB103K25
		C 240	CKSYB104K16
		C 241	CKSQYB104K16
		C 242	CEALR47M50
		C 244	CKSQYB473K16
		C 245	CKSQYB103K25
		C 248	CKSQYB334K16
		C 250	CCSRCJ3R0C50
CAPACITORS			
C 1	CCSRCH220J50		
C 2	CKSRYB222K50		
C 3	CCSRCH4R0D50		
C 5	CKSRYB222K50		
C 6	CKSQYB473K16		
C 7	CKSQYB473K16		
C 8	CKSQYB104K16		
C 9	CKSRYB222K50		
C 10	CEAL1R0M50		
C 11	CCSRCH470J50		
C 12	CCSRCJ3R0C50		
C 13	CKSRYB222K50		
C 15	CCSRCJ3R0D50		
C 17	CCSRCH120J50		
C 18	CKSRYB103K25		
C 19	CCSRCH120J50		
C 20	CKSRYB222K50		
C 21	CEAL100M16		
C 22	CCSRRH100D50		
C 23	CCSRRH150J50		
C 24	CCSRCH471J50		
C 30	CCSRRH201J50		
C 31	CKSRYB103K25		
C 32	CKSQYB473K16		
C 33	CCSRCH220J50		
C 34	CCSRCH4R0D50		
C 41	CKSQYB104K16		
C 51	CKSRYB223K25		
C 52	CKSRYB103K25		
C 54	CCSRCH470J50		
C 55	CKSQYB223K25		
C 56	CKSQYB104K16		
C 57	CKSRYB472K50		
C 58	CEJA330M10		
C 59	CKSRYB103K25		
C 61	CCSRCH270J50		
C 62	CKSRYB103K25		
C 63	CEALR22M50		
C 65	CKSQYB104K16		
C 101	CEALNP100M10		
C 102	CKSRYB182K50		
C 103	CKSQYB682K50		
C 104	CEAL2R2M50		
C 105	CKSRYB103K25		
C 106	CCSRCH151J50		
C 107	CKSRYB103K25		
C 151	CKSRYB562K25		
C 152	CKSQYB104K16		
C 153	CEAL3R3M50		
C 154	CKSQYB104K16		

A Unit Number : CWM7046
Unit Name : Main Unit

MISCELLANEOUS

IC 201	IC	PM2007A
IC 251	IC	NJM2903M
IC 252	IC	PM4006B
IC 301	IC	NJM2068MD
IC 302	IC	NJM2068MD
IC 303	IC	NJM2068MD
IC 305	IC	TC74HC4066AF
IC 501	IC	LA1061M
IC 553	IC	HA12181FP
IC 601	IC	PD5569A
IC 602	IC	HA12187FP
IC 603	IC	S-80730ANDT
Q 202	Chip Transistor	2SC2712
Q 251	Chip Transistor	2SC2712
Q 301	Transistor	FMG13
Q 303	Transistor	FMG13
Q 304	Transistor	FMG13
Q 305	Transistor	DTA114EK
Q 307	Transistor	IMD3A
Q 308	Transistor	DTC144TK

FX-MG8217ZT, MG8217ZT-91

====Circuit Symbol and No.====Part Name	Part No.	====Circuit Symbol and No.====Part Name	Part No.
Q 401	Transistor	FMG13	
Q 402	Transistor	FMG13	
Q 403	Transistor	FMG13	
Q 405		IMH4	
Q 406	Transistor	IMX1	
Q 501	Transistor	IMX1	
Q 503	Chip Transistor	2SC2712	
Q 504	Transistor	DTC114EU	
Q 505	Transistor	2SD2351	
Q 506	Transistor	DTC114EU	
Q 507	Transistor	DTC114EU	
Q 551	Chip Transistor	2SC2712	
Q 601	Transistor	2SA1162	
Q 603	Transistor	DTA144EK	
Q 604	Transistor	DTA114EK	
Q 607	Transistor	DTA114EK	
Q 702	Transistor	DTA114EK	
Q 801	Transistor	DTC114EK	
Q 802	Transistor	IMX1	
Q 804	Transistor	2SD1664	
Q 805	Transistor	DTC144TK	
Q 806	Transistor	DTC144TK	
Q 807	Transistor	DTC144TK	
Q 808	Transistor	2SB1184F5	
Q 809	Transistor	2SB1185	
Q 811	Transistor	2SB1185	
Q 812	Transistor	2SB1185	
Q 813	Transistor	2SA1162	
Q 814	Transistor	2SA1162	
Q 815	Transistor	IMX1	
Q 816	Transistor	IMX1	
Q 818	Transistor	2SB1184F5	
Q 819	Transistor	2SA1162	
Q 820	Transistor	IMX1	
Q 822	Transistor	2SB1132	
Q 823	Transistor	DTC123EK	
Q 825	Transistor	2SA1162	
Q 829	Transistor	2SB1188	
Q 830	Transistor	DTC123YK	
Q 831	Transistor	DTA114EK	
Q 861	Transistor	2SB1132	
Q 862	Transistor	2SB1132	
Q 863	Transistor	2SB1132	
Q 864	Transistor	IMX1	
Q 871	Transistor	2SA1162	
Q 872	Transistor	DTC144EK	
Q 891	Transistor	2SA1162	
Q 892	Transistor	2SA1162	
Q 893	Transistor	DTC144EK	
Q 894	Transistor	DTC144EK	
D 201	Diode	1SS355	
D 301	Diode	UDZ20(B)	
D 302	Diode	UDZ20(B)	
D 303	Diode	UDZ20(B)	
D 304	Diode	UDZ20(B)	
D 305	Diode	HZU4LL(C)	
D 306	Diode	HZU8R2(B3)	
D 400	Diode	1SS355	
D 501	Diode	1SV241	
D 502	Diode	1SV241	
D 503	Diode	DAP202K	
D 507	Diode	1SS355	
D 519	Diode	DAN202K	
D 605	Diode	1SS355	
D 611	Diode	UDZ18(B)	
D 612	Diode	UDZ18(B)	
D 655	Diode	DAN202K	
D 801	Diode	1SS355	
D 802	Diode	UDZS5R6(B)	
D 803	Diode	RM4LFJ10	
D 804	Diode	1SS355	
D 805	Diode	UDZ20(B)	
D 806	Diode	ERA15-02VH	
D 807	Diode	UDZS5R6(B)	
D 808	Diode	HZU8R2(B1)	
D 809	Diode	HZU8R2(B1)	
D 810	Diode	HZU8R2(B1)	
D 811	Diode	1SS355	
D 812	Diode	HZU8R2(B1)	
D 813	Diode	1SS355	
D 814	Diode	HZU8R2(B3)	
D 818	Diode	UDZS5R1(B)	
D 821	Diode	1SS355	
D 871	Diode	1SS355	
D 891	Diode	1SS355	
D 892	Diode	1SS355	
L 201	Chip-Inductor	LCTA2R2J3225	
L 202	Inductor	LCTA4R7J3225	
L 251	Inductor	LCTA101J3225	
L 501	Inductor	LCTA4R7J3225	
L 502	Inductor	LCTA4R7J3225	
L 503	Inductor	LCTA4R7J3225	
L 504	Inductor	LCTB4R7K3216	
L 511	Inductor	LCTB6R8K3216	
L 512	Inductor	LCTB6R8K3216	
L 513	Inductor	LCTB6R8K3216	
L 515	Inductor	LCTA4R7J3225	
L 516	Inductor	LCTA561J4532	
L 551	Inductor	LCTA101J3225	
L 601	Inductor	LCTA100J3225	
L 801	Coil 350μH	CTH1092	
CG 501	Surge Protector	DSP-201M-A21F	
CG 502	Surge Protector	DSP-201M-A21F	
X 201	Crystal Resonator 7.200MHz	CSS1379	
X 251	Crystal Resonator 4.332MHz	CSS1056	
X 601	Radiator 10.00MHz	CSS1428	
VR 251	2.2kΩ(B)	CCP1392	
VR 552	10kΩ(B)	CCP1396	
FU 801	Fuse 5A	CEK1195	
	FM/AM Tuner Unit	CWE1543	
RESISTORS			
R 200		RS1/10S183J	
R 201		RS1/10S473J	
R 202		RS1/10S102J	
R 203		RS1/10S222J	
R 204		RS1/10S222J	
R 205		RS1/10S103J	
R 206		RS1/10S473J	
R 207		RS1/10S102J	
R 208		RS1/10S102J	
R 209		RS1/10S123J	
R 210		RS1/10S472J	
R 211		RS1/10S682J	
R 212		RS1/10S222J	
R 213		RS1/10S682J	
R 214		RS1/10S102J	
R 215		RS1/10S472J	
R 216		RS1/10S561J	
R 217		RS1/10S682J	
R 218		RS1/10S472J	
R 219		RS1/10S152J	
R 220		RS1/10S392J	
R 221		RS1/10S222J	
R 222		RS1/10S392J	
R 223		RS1/10S272J	
R 224		RS1/10S102J	

====Circuit Symbol and No.====Part Name	Part No.	====Circuit Symbol and No.====Part Name	Part No.
R 225	RS1/10S102J	R 349	RS1/10S392J
R 226	RS1/10S102J	R 351	RS1/10S0R0J
R 227	RS1/10S102J	R 352	RS1/10S0R0J
R 228	RS1/10S103J	R 353	RS1/10S0R0J
R 229	RS1/10S473J	R 401	RS1/10S272J
R 231	RS1/10S105J	R 402	RS1/10S272J
R 232	RS1/10S151J	R 403	RS1/10S222J
R 233	RS1/10S0R0J	R 405	RS1/10S102J
R 251	RS1/10S102J	R 406	RS1/10S102J
R 252 1kΩ	CCN1120	R 407	RS1/10S182J
R 256	RS1/10S102J	R 408	RS1/10S182J
R 257	RS1/10S102J	R 409	RS1/10S222J
R 258	RS1/10S0R0J	R 411	RS1/10S683J
R 259	RS1/10S333J	R 412	RS1/10S683J
R 260	RS1/10S104J	R 413	RS1/10S183J
R 261	RS1/10S104J	R 414	RS1/10S183J
R 262	RS1/10S681J	R 415	RS1/10S103J
R 263	RS1/10S684J	R 416	RS1/10S103J
R 264	RS1/10S222J	R 434	RS1/10S224J
R 265	RS1/10S222J	R 435	RS1/10S224J
R 266	RS1/10S562J	R 436	RS1/10S224J
R 267	RS1/10S222J	R 437	RS1/10S222J
R 268	RS1/10S102J	R 438	RS1/10S222J
R 271	RS1/10S562J	R 501	RS1/10S104J
R 301	RS1/10S182J	R 502	RS1/10S103J
R 302	RS1/10S182J	R 503	RS1/10S103J
R 303	RS1/10S473J	R 504	RS1/10S334J
R 304	RS1/10S473J	R 505	RS1/10S101J
R 307	RS1/10S363J	R 506	RS1/10S101J
R 308	RS1/10S363J	R 507	RS1/10S104J
R 309	RS1/10S473J	R 508	RS1/10S104J
R 310	RS1/10S473J	R 509	RS1/10S103J
R 311	RS1/10S563J	R 510	RS1/10S182J
R 312	RS1/10S563J	R 511	RS1/10S683J
R 313	RS1/10S102J	R 512	RS1/10S153J
R 314	RS1/10S102J	R 513	RS1/10S103J
R 315	RS1/10S473J	R 514	RS1/10S224J
R 316	RS1/10S473J	R 515	RS1/10S473J
R 319	RS1/10S223J	R 516	RS1/10S473J
R 320	RS1/10S223J	R 517	RS1/10S102J
R 321	RS1/10S223J	R 519	RS1/10S393J
R 322	RS1/10S223J	R 521	RS1/10S103J
R 323	RS1/10S222J	R 522	RS1/10S114J
R 324	RS1/10S222J	R 523	RS1/10S273J
R 325	RS1/10S222J	R 525	RS1/10S103J
R 326	RS1/10S222J	R 530	RS1/10S225J
R 327	RS1/10S510J	R 531	RS1/10S225J
R 328	RS1/10S510J	R 532	RS1/10S225J
R 329	RS1/10S510J	R 533	RS1/10S225J
R 330	RS1/10S510J	R 536	RS1/10S472J
R 333	RS1/10S510J	R 537	RS1/10S471J
R 334	RS1/10S510J	R 538	RS1/10S102J
R 335	RS1/10S510J	R 541	RS1/10S103J
R 336	RS1/10S510J	R 570	RS1/10S104J
R 337	RS1/10S103J	R 571	RS1/10S123J
R 339	RS1/10S392J	R 572	RS1/10S105J
R 340	RS1/10S392J	R 573	RS1/10S822J
R 341	RS1/10S473J	R 574	RS1/10S822J
R 342	RS1/10S473J	R 575	RS1/10S222J
R 343	RS1/10S472J	R 576	RS1/10S184J
R 344	RS1/10S102J	R 577	RS1/10S223J
R 345	RS1/10S223J	R 578	RS1/10S473J
R 346	RS1/10S103J	R 601	RS1/10S102J
R 347	RS1/10S104J	R 602	RS1/10S222J
R 348	RS1/10S153J	R 603	RS1/10S222J

FX-MG8217ZT, MG8217ZT-91

====Circuit Symbol and No.====Part Name	Part No.	====Circuit Symbol and No.====Part Name	Part No.
R 604	RS1/10S471J	R 828	RS1/10S102J
R 605	RA3C102J	R 829	RS1/10S223J
R 607	RS1/10S473J	R 830	RS1/10S221J
R 608	RS1/10S102J	R 831	RS1/10S331J
R 609	RS1/10S681J	R 832	RS1/10S471J
R 610	RS1/10S102J	R 833	RS1/10S102J
R 611	RS1/10S473J	R 840	RS1/4S1R5J
R 612	RA2CQ102J	R 841	RS1/4S1R5J
R 613	RS1/10S473J	R 842	RS1/4S1R5J
R 614	RS1/10S0R0J	R 843	RS1/4S1R5J
R 616	RS1/10S473J	R 844	RS1/10S471J
R 617	RS1/10S102J	R 845	RS1/10S471J
R 618	RS1/10S472J	R 846	RS1/10S105J
R 619	RA2CQ102J	R 847	RS1/10S361J
R 620	RA2CQ473J	R 848	RS1/10S152J
R 621	RA3C102J	R 849	RS1/10S242J
R 622	RA3C473J	R 850	RS1/4S2R2J
R 623	RA3C103J	R 851	RS1/10S471J
R 624	RS1/10S103J	R 852	RS1/10S105J
R 625	RA3C102J	R 853	RS1/10S102J
R 626	RA3C473J	R 854	RS1/10S152J
R 627 1kΩ	CCN1120	R 855	RS1/10S242J
R 628 47kΩ	CCN1131	R 856	RS1/10S103J
R 629	RS1/10S473J	R 857	RS1/10S332J
R 631	RA3C102J	R 858	RS1/8S821J
R 632 1kΩ	CCN1120	R 859	RS1/10S103J
R 633	RS1/10S473J	R 860	RS1/10S103J
R 634	RS1/10S473J	R 861	RS1/10S332J
R 635	RS1/10S102J	R 862	RS1/10S332J
R 637	RA3C104J	R 863	RS1/10S332J
R 639	RS1/10S223J	R 864	RS1/10S332J
R 640 1kΩ	CCN1120	R 865	RS1/10S332J
R 641 47kΩ	CCN1131	R 866	RS1/10S332J
R 642	RS1/10S102J	R 869	RS1/10S103J
R 643	RA3C102J	R 870	RS1/4S391J
R 644	RS1/10S681J	R 871	RD1/4PU221J
R 645	RA2CQ102J	R 873	RS1/10S223J
R 646	RS1/10S102J	R 874	RS1/10S103J
R 647	RS1/10S473J	R 875	RS1/10S473J
R 648	RS1/10S102J	R 881	RS1/10S103J
R 649	RS1/10S473J	R 882	RS1/10S103J
R 650	RS1/10S102J	R 891	RD1/4PU221J
R 651	RS1/10S104J	R 892	RD1/4PU221J
R 652	RS1/4S101J	R 893	RS1/10S223J
R 653	RS1/4S101J	R 894	RS1/10S223J
R 654	RS1PMF680J	R 895	RS1/10S103J
R 655	RS1/8S221J	R 896	RS1/10S103J
R 658	RS1/10S473J	R 897	RS1/10S473J
R 660	RS1/10S0R0J	R 898	RS1/10S473J
R 801	RS1/8S222J		
R 802	RS1/8S472J	CAPACITORS	
R 803	RS1/8S472J	C 201	CKSQYB103K50
R 804	RS1/8S472J	C 202	CKSQYB103K50
R 805	RS1/8S472J	C 203	CKSQYB473K50
R 806	RS1/8S472J	C 205	CCSQCH101J50
R 807	RS1/8S221J	C 206	CKSQYB223K50
R 810	RS1/10S104J		
R 812	RS1/10S104J	C 207	CKSQYB473K50
R 814	RS1/10S104J	C 208	CEJA101M10
R 815	RS1/10S223J	C 209	CEJA220M10
R 816	RS1/10S102J	C 210	CKSQYB103K50
R 819	RS1/10S102J	C 211	CKSQYB103K50
R 820	RS1/10S123J	C 212	CEJA220M10
R 821	RS1/10S103J	C 213	CKSQYB103K50
R 822	RS1/10S103J	C 215	CCH1280
R 823	RS1/10S223J	C 216	CKSQYB103K50
R 824	RS1/10S102J	C 220	CKSQYB103K50
R 825	RS1/10S331J		
R 826	RS1/10S103J		
R 827	RS1/10S471J		

====Circuit Symbol and No.====Part Name	Part No.	====Circuit Symbol and No.====Part Name	Part No.
C 221 4.7μF/10V	CCH1280	C 408	CKSQYB103K50
C 223	CKSQYB103K50	C 413 4.7μF/35V	CCH1016
C 224	CCSQCH150J50	C 414 4.7μF/35V	CCH1016
C 225	CCSQCH120J50	C 415	CCSQCH101J50
C 226	CKSQYB102K50	C 416	CCSQCH101J50
C 227	CKSQYB103K50	C 434	CKSQYB153K50
C 229	CKSQYB471K50	C 435	CKSQYB105K16
C 251	CKSQYB104K50	C 436	CEJA101M10
C 253	CEAL4R7M35	C 503	CKSQYB222K50
C 254	CKSQYB473K50	C 504	CKSQYB222K50
C 256	CCSQCH220J50	C 505	CKSQYB222K50
C 257	CCSQCH220J50	C 507	CKSQYB103K50
C 258	CKSQYB472K50	C 508	CKSQYB103K50
C 259	CKSQYB104K50	C 509	CEAL100M16
C 260	CKSQYB105K16	C 510	CKSQYB472K50
C 261	CKSQYB104K50	C 511	CEAL100M16
C 262	CKSQYB222K50	C 512	CKSQYB473K50
C 264	CKSQYB103K50	C 513	CEAL2R2M50
C 265	CKSQYB103K50	C 514	CKSQYB102K50
C 266	CKSQYB223K50	C 515	CKSQYB103K50
C 267	CKSQYB104K50	C 516	CKSQYB103K50
C 301 4.7μF/35V	CCH1016	C 517	CKSQYB392K50
C 302 4.7μF/35V	CCH1016	C 519	CKSQYB472K50
C 305 4.7μF/35V	CCH1016	C 521	CKSQYB222K50
C 306 4.7μF/35V	CCH1016	C 522	CKSQYB104K25
C 307 4.7μF/35V	CCH1016	C 523	CKSQYB102K50
C 308 4.7μF/35V	CCH1016	C 535	CKSQYB103K50
C 309	CCSQCH120J50	C 536	CKSQYB103K50
C 310	CCSQCH120J50	C 537	CKSQYB103K50
C 311 4.7μF/35V	CCH1016	C 581	CEAL3R3M50
C 312 4.7μF/35V	CCH1016	C 582	CKSQYB333K50
C 313 4.7μF/35V	CCH1016	C 583	CEALNP1R0M50
C 314 4.7μF/35V	CCH1016	C 584	QOMA683J50
C 315	CCSQCH330J50	C 585	QOMA333J50
C 316	CCSQCH330J50	C 586	QOMA333J50
C 317	CKSQYB331K50	C 587	QOMA333J50
C 318	CKSQYB331K50	C 588	CKSQYB393K50
C 319	CKSQYB682K50	C 589	CKSQYB682K50
C 320	CKSQYB682K50	C 590	CKSQYB682K50
C 321	CKSQYB682K50	C 591	CKSQYB392K50
C 322	CKSQYB682K50	C 592	CKSQYB102K50
C 323	CEALNP4R7M16	C 593	CKSQYB334K16
C 324	CEALNP4R7M16	C 594	CKSQYB334K16
C 325	CEALNP4R7M16	C 601	CKSQYB102K50
C 326	CEALNP4R7M16	C 603	CEAL100M16
C 327	CCSQCH101J50	C 604	CKSQYB104K50
C 328	CCSQCH101J50	C 605	CKSQYB103K50
C 329	CCSQCH101J50	C 606	CCSQCH101J50
C 330	CCSQCH101J50	C 607	CCSQCH101J50
C 331	CKSQYB224K16	C 608	CCSQCH101J50
C 333	CKSQYB103K50	C 609	CCSQCH101J50
C 334	CEAL101M6R3	C 610	CCSQCH101J50
C 335	CEJA470M10	C 611	CCSQCH101J50
C 336	CKSQYB103K50	C 612	CCSQCH101J50
C 337	CEAL4R7M35	C 615	CCSQCH101J50
C 339 4.7μF/35V	CCH1016	C 616	CCSQCH101J50
C 340 4.7μF/35V	CCH1016	C 619	CCSQCH101J50
C 341	CEAL100M16	C 625	CKSQYB103K50
C 343	CCSQCH101J50	C 626	CKSQYB103K50
C 344	CCSQCH101J50	C 627	CKSQYB221K50
C 401	CKSQYB224K25	C 628	CKSQYB221K50
C 402	CKSQYB224K25	C 648	CKSQYB102K50
C 405	CKSQYB273K50	C 650	CKSQYB102K50
C 406	CKSQYB273K50	C 655	CKSQYB473K50
C 407	CKSQYB103K50	C 801	CKSQYB102K50

FX-MG8217ZT, MG8217ZT-91

====Circuit Symbol and No.====	Part Name	Part No.
C 802		CEAL1R0M50
C 803		CKSQYB102K50
C 804	2200μF/16V	CCH1186
C 805		CKSQYB473K50
C 806		CKSQYB102K50
C 807		CEAL1R0M50
C 808		CKSQYB102K50
C 809	2200μF/16V	CCH1186
C 811		CCSQCH101J50
C 812		CKSQYB103K50
C 813		CEJA221M6R3
C 814		CEAL1R0M50
C 815		CEAL1R0M50
C 816		CKSQYB103K50
C 817	100μF/10V	CCH1402
C 818		CKSQYB103K50
C 819	100μF/10V	CCH1282
C 820		CKSQYB103K50
C 824		CKSQYB472K50
C 825	100μF/10V	CCH1402
C 826		CKSQYB472K50
C 828		CKSQYB102K50
C 829		CKSQYB103K50
C 830		CKSQYB103K50
C 831		CKSQYB103K50
C 832		CKSQYB103K50
C 861		CKSQYB223K50
C 862		CKSQYB223K50
C 863		CKSQYB223K50
C 871		CKSQYB103K50
C 891		CKSQYB103K50
C 892		CKSQYB103K50

====Circuit Symbol and No.====	Part Name	Part No.
R 721		RS1/10S102J
R 722		RA2CQ222J
R 723		RA2CQ473J
R 724		RS1/10S102J
R 725		RA3C471J
R 726		RA2CQ102J
R 727		RA2CQ102J
R 728	470Ω	CCN1117
R 729	470Ω	CCN1117
R 730	470Ω	CCN1117
R 731		RS1/10S471J
R 732		RS1/10S912J
R 733		RS1/10S102J
R 734	2.2kΩ	CCN1121
R 735		RS1/10S273J
R 736		RS1/10S512J
R 737		RS1/10S104J
R 738		RS1/10S154J
R 739		RS1/10S183J
R 740		RS1/10S102J

CAPACITORS

C 701	CKSYB102K50
C 702	CKSQYB102K50
C 704	CKSQYB102K50
C 705	CKSQYB102K50
C 706	CKSQYB102K50
C 709	CCSQCH101J50
C 711	CKSQYB102K50
C 712	CKSQYB102K50
C 714	CCSQCH180J50
C 715	CCSQCH180J50
C 716	CKSQYB102K50
C 717	CKSQYB102K50
C 718	CKSQYB102K50
C 719	CKSQYB102K50
C 721	CKSQYB102K50
C 722	CKSQYB105K10
C 723	CKSQYB103K50
C 724	CKSQYB102K50
C 725	CKSQYB102K50
C 726	CKSQYB102K50
C 727	CKSQYB102K50
C 728	CKSQYB102K50

Q Unit Number : CWM7048
Unit Name : Control Unit

MISCELLANEOUS

IC 701	IC	PD5575B
Q 701	Transistor	DTA144EK
D 701	Diode	1SS355
L 701	Inductor	LCTB100K3216
L 702	Inductor	LCTB100K3216
TH 701	Thermistor	CCX1036
X 701	Ceramic Resonator 6.290MHz	CSS1367

RESISTORS

R 701		RS1/10S433J
R 702		RS1/10S103J
R 703		RS1/10S222J
R 704		RS1/8S103J
R 705		RS1/10S102J
R 706		RA2CQ222J
R 707		RA2CQ103J
R 708	330Ω	CCN1116
R 709		RA2CQ222J
R 710		RS1/10S104J
R 711		RS1/10S331J
R 712		RS1/10S103J
R 713		RS1/10S102J
R 714		RA2CQ222J
R 715		RA2CQ103J
R 716		RA2CQ102J
R 717		RS1/10S102J
R 718		RS1/10S471J
R 719		RS1/10S102J
R 720		RA2CQ471J

C Unit Number : CWS1332
Unit Name : Keyboard Unit

MISCELLANEOUS

IC 901	IC	LC75804W
Q 901	Transistor	2SB1132
Q 902	Transistor	DTC123YK
D 901	Chip LED	NSCW310-0371
D 902	Chip LED	NSCW310-0371
D 904	Chip LED	NSCW310-0371
D 905	Chip LED	NSCW310-0371
D 907	Diode	DAP202K
D 908	Diode	1SS355
D 909	Diode	1SS355
D 910	Diode	1SS355
D 911	Diode	1SS355
D 912	Diode	1SS355
D 913	LED	SML210FT
D 914	LED	SML210FT

====Circuit Symbol and No.====	Part Name	Part No.
D 920	Diode	HZU4R7(B3)
S 924	Switch(DCLOSE)	CSN1051
IL 901	Lamp 8V 60mA	CEL1685
IL 902	Lamp 8V 60mA	CEL1685
IL 903	Lamp 8V 60mA	CEL1686
IL 904	Lamp 8V 60mA	CEL1686
IL 905	Lamp 8V 60mA	CEL1686
IL 906	Lamp 8V 60mA	CEL1686
IL 907	Lamp 8V 60mA	CEL1685
IL 908	Lamp 8V 60mA	CEL1685
IL 909	Lamp 8V 60mA	CEL1685
IL 910	Lamp 8V 60mA	CEL1685
IL 911	Lamp 8V 60mA	CEL1685
IL 912	Lamp 8V 60mA	CEL1685
IL 913	Lamp 8V 60mA	CEL1685
IL 914	Lamp 8V 60mA	CEL1685
VR 901	Encoder	CSD1065
VR 902	Encoder	CSD1048
LCD 901	LCD	CAW1690

RESISTORS

R 901		RS1/10S241J
R 902		RS1/10S241J
R 904		RS1/10S241J
R 905		RS1/10S241J
R 907		RS1/16S223J
R 908		RS1/16S223J
R 909	1kΩ	CCN1120
R 910	1kΩ	CCN1120
R 912		RS1/16S681J
R 914	1kΩ	CCN1120
R 917		RS1/16S102J
R 918		RS1/16S103J
R 919		RS1/16S223J
R 920		RS1/10S561J
R 921		RS1/10S222J
R 923		RS1/10S222J
R 924		RS1/10S222J
R 925		RS1/16S393J
R 933	1kΩ	CCN1120
R 934		RS1/10S241J
R 935		RS1/10S161J
R 936		RS1/10S241J
R 937		RS1/10S103J
R 938		RS1/10S0R0J
R 939		RS1/10S0R0J

CAPACITORS

C 901		CKSQYB104K50
C 902		CKSQYB104K50
C 904		CKSQYB104K50
C 905		CKSQYB104K50
C 907		CCSRCH101J50
C 908		CCSRCH101J50
C 909		CKSRYB474K10
C 910		CKSRYB103K50
C 911		CKSRYB104K16
C 913		CKSRYB104K16
C 914		CKSRYB104K16
C 917		CKSRYB102K50
C 919		CKSQYB104K50
C 923		CCSRCH101J50
C 924		CCSRCH101J50
C 925		CCSRCH101J50
C 926		CCSRCH101J50

====Circuit Symbol and No.====	Part Name	Part No.
--------------------------------	-----------	----------

E Unit Number : CWX2421
 Unit Name : CD Core Unit(Servo Unit)

MISCELLANEOUS

IC 101	IC	UPC2572GS
IC 201	IC	UPD63702AGF
IC 301	IC	BA5986FM
Q 101	Transistor	2SD1664
Q 102	Transistor	UMD2N
D 301	Diode	1SR154-400
L 201	Inductor	LCYBR15J1608
L 202	Inductor	LCYBR15J1608
X 201	Ceramic Resonator 16.934MHz	CSS1457
EF 201	Filter	CCG1076
EF 202	Filter	CCG1076

RESISTORS

R 101		RS1/8S100J
R 102		RS1/8S120J
R 104		RS1/16S822J
R 105		RS1/16S682J
R 106		RS1/16S183J
R 107		RS1/16S822J
R 108		RS1/16S333J
R 109		RS1/16S683J
R 110		RS1/16S134J
R 111		RS1/16S273J
R 112		RS1/16S222J
R 113		RS1/16S103J
R 114		RS1/16S103J
R 115		RS1/16S102J
R 116		RS1/16S163J
R 117		RS1/16S163J
R 120		RS1/16S101J
R 121		RS1/16S101J
R 201		RS1/16S104J
R 202		RS1/16S103J
R 203		RS1/16S332J
R 204		RS1/16S752J
R 205		RS1/16S752J
R 206		RS1/16S101J
R 250		RS1/16S331J
R 251		RS1/16S331J
R 252		RS1/16S331J
R 253		RS1/16S331J
R 254		RS1/16S331J
R 255		RS1/16S471J
R 256		RS1/16S471J
R 263		RS1/16S471J
R 270		RS1/16S101J
R 271		RS1/16S101J
R 274		RS1/16S471J
R 277		RS1/16S471J
R 301		RS1/16S103J
R 302		RS1/16S153J
R 303		RS1/16S103J
R 304		RS1/16S273J
R 305		RS1/16S103J
R 306		RS1/16S752J
R 307		RS1/16S103J
R 308		RS1/16S103J
R 309		RS1/16S471J
R 311		RS1/16S471J

====Circuit Symbol and No.====Part Name Part No.

CAPACITORS

C	101		CEV101M6R3
C	102		CKSQYB104K16
C	103		CEV470M6R3
C	104		CKSQYB334K16
C	105		CCSRCH240J50
C	106		CKSRYB222K50
C	107		CEV4R7M35
C	108		CKSRYB273K25
C	109		CCSRCH101J50
C	110		CKSQYB104K16
C	111		CKSRYB332K50
C	112		CKSQYB473K16
C	113		CKSRYB103K25
C	114		CKSRYB391K50
C	115		CCSRCH121J50
C	116		CKSRYB682K50
C	117		CKSRYB333K16
C	118		CKSQYB334K16
C	119		CKSQYB334K16
C	120		CKSQYB334K16
C	121		CKSQYB334K16
C	122		CKSQYB104K16
C	123		CKSRYB472K50
C	124		CKSQYB104K16
C	125		CCSRCH5R0C50
C	126		CKSRYB153K25
C	127		CKSRYB102K50
C	201		CKSQYB334K16
C	202		CKSQYB104K16
C	203		CKSQYB104K16
C	204		CKSRYB471K50
C	207		CKSQYB683K16
C	208		CKSRYB821K50
C	209		CKSRYB273K25
C	210		CKSQYB334K16
C	211		CKSQYB334K16
C	212		CKSQYB334K16
C	213	10μF/10V	CCH1349
C	301		CEV101M10
C	302		CEV101M10

G Unit Number : CWX2422
Unit Name : CD Core Unit(STS Unit)

MISCELLANEOUS

IC	501	IC	CXD2511R
IC	502	IC	MSM514400DP-60TS
IC	601	IC	AK4321VF
IC	701	IC	BA05SFP
IC	801	IC	LB1836M
IC	802	IC	LB1836M
Q	801	Transistor	DTA123JK
Q	802	Transistor	UN2211
D	701	Diode	1SR154-400
D	702	Diode	1SR154-400
D	703	Diode	1SS355
D	704	Diode	1SS355
D	705	Diode	1SS355
D	706	Diode	1SS355
D	707	Diode	1SS355
D	708	Diode	1SS355
S	801	Spring Switch(LOAD)	CSN1052
S	802	Spring Switch(DOOR)	CSN1052
S	803	Spring Switch(MODE)	CSN1052
EF	701	Filter	CCG1051

====Circuit Symbol and No.====Part Name Part No.

EF	702	Filter	CCG1051
EF	703	Filter	CCG1051

RESISTORS

R	501		RS1/16S102J
R	502		RS1/16S202J
R	503		RS1/16S392J
R	504		RS1/16S822J
R	505		RS1/16S163J
R	506		RS1/16S512J
R	507		RS1/16S182J
R	508		RS1/16S222J
R	509		RS1/16S102J
R	510		RS1/16S102J
R	511		RS1/16S102J
R	512		RS1/16S102J
R	513		RS1/16S102J
R	514		RS1/16S471J
R	601		RS1/16S101J
R	602		RS1/16S101J
R	603		RS1/16S471J
R	604		RS1/16S471J
R	702		RS1/10S100J
R	716		RS1/16S471J
R	717		RS1/16S471J
R	718		RS1/16S471J
R	801		RS1/10S102J

CAPACITORS

C	501		CKSQYB334K16
C	502		CKSQYB334K16
C	503		CKSQYB334K16
C	504		CCSRCH471J50
C	506		CCSRCH221J50
C	601		CKSQYB334K16
C	602		CCSRCH221J50
C	603		CKSQYB334K16
C	604		CKSQYB334K16
C	605		CSZSR100M10
C	606		CKSQYB334K16
C	701	10μF/10V	CCH1349
C	702		CEVL101M6R3
C	703		CKSQYB334K16
C	704		CKSQYB334K16
C	705		CCSRCH151J50
C	706		CCSRCH151J50
C	707		CCSRCH151J50
C	801		CKSQYB104K25
C	802		CKSQYB104K25
C	803		CEVL220M16

L Unit Number :
Unit Name : PCB Unit(A)

D	891	Chip LED	CL205IRXTU
D	892	Chip LED	CL205IRXTU

H Unit Number :
Unit Name : PCB Unit(B)

S	886	Spring Switch(ELV Home)	CSN1052
S	887	Spring Switch(Clamp)	CSN1051

J Unit Number :
Unit Name : PCB Unit(C)

Q	881	Photo-transistor	CPT230SCTD
D	883	Chip LED	CL205IRXTU
S	885	Spring Switch(MAX DETECT)	CSN1052
L	801	Inductor	LCYBR15J1608
L	802	Inductor	LCYBR15J1608

====Circuit Symbol and No.====Part Name Part No.

M Unit Number :
Unit Name : PCB Unit(D)
Q 851 Photo-transistor CPT230SCTD
Q 852 Photo-transistor CPT230SCTD
L 1 Inductor LCYBR15J1608
L 2 Inductor LCYBR15J1608

I Unit Number :
Unit Name : PCB Unit(E)
R 856 RS1/8S911J
R 857 RS1/8S821J

F Unit Number :
Unit Name : Motor PCB(A)
Q 1 Photo-interrupter RPI-221
M 1 Motor Unit(Cam Gear) CXB6929
M 3 Motor Unit(ELV) CXB3175

D Unit Number :
Unit Name : Motor PCB(B)
M 4 Motor Unit(Carriage) CXB3178
M 5 Motor(Spindle) CXM1120

K Unit Number :
Unit Name : Load Motor PCB
M 2 Motor Unit(Load) CXB3177

N Unit Number : EWM1030
Unit Name : Deck Unit

MISCELLANEOUS

IC 251 IC HA12216F
IC 351 IC PA2020A
Q 271 Transistor 2SC4116
Q 351 Transistor 2SB1260
Q 352 Transistor 2SC4102
D 351 Diode 1SS355
VR 301 Semi-fixed 33kΩ(B) CCP1280
VR 302 Semi-fixed 33kΩ(B) CCP1280

RESISTORS

R 255 RS1/16S181J
R 256 RS1/16S181J
R 257 RS1/16S183J
R 258 RS1/16S183J
R 259 RS1/16S133J
R 260 RS1/16S133J
R 261 RS1/16S274J
R 262 RS1/16S274J
R 271 RS1/16S183J
R 272 RS1/8S0R0J
R 273 RS1/8S0R0J
R 275 RS1/16S473J
R 276 RS1/16S104J
R 277 RS1/16S224J
R 278 RS1/16S104J
R 281 RS1/8S0R0J
R 282 RS1/8S0R0J
R 283 RS1/8S0R0J
R 284 RS1/8S0R0J
R 285 RS1/8S0R0J
R 286 RS1/8S0R0J
R 287 RS1/8S0R0J
R 288 RS1/8S0R0J
R 292 RS1/8S0R0J
R 296 RS1/16S0R0J

====Circuit Symbol and No.====Part Name Part No.

R 321 RS1/8S0R0J
R 322 RS1/16S0R0J
R 351 RS1/16S102J
R 352 RS1/16S102J
R 353 RS1/16S102J
R 354 RS1/16S102J
R 355 RS1/10S274J
R 356 RS1/10S202J
R 357 RS1/10S472J
R 358 RS1/10S103J
R 359 RS1/10S103J
R 360 RS1/10S102J
R 361 RS1/10S622J
R 362 RS1/8S181J
R 373 RS1/8S0R0J
R 374 RS1/8S0R0J
R 375 RS1/8S0R0J
R 401 RS1/16S123J
R 402 RS1/16S332J
R 403 RS1/16S911J
R 404 RS1/16S274J

CAPACITORS

C 251 CKSRYB391K50
C 252 CKSRYB391K50
C 253 CKSRYB391K50
C 254 CKSRYB391K50
C 255 CKSRYB103K50
C 256 CKSRYB103K50
C 271 CEV1R0M50
C 272 CKSQYB104K16
C 301 CKSRYB104K16
C 302 CKSRYB104K16
C 309 CKSQYB104K16
C 310 CKSQYB104K16
C 351 CKSYB224K25
C 352 CKSQYB392K50
C 353 CKSQYB103K50
C 354 CKSQYB103K50
C 355 CKSYB104K50
C 356 CKSQYB103K50
C 401 CKSQYB472K50
C 402 CKSQYB334K16
C 403 CKSQYB223K25
C 404 CKSRYB103K50
C 405 CKSRYB333K16

O Unit Number :
Unit Name : PCB Unit
L 1 Inductor ETH0002
S 1 Switch (LOAD) ESG1004
S 2 Switch (70μs) ESG1004
EGN 1 Photo-Interrupter EGN1005

P Unit Number :
Unit Name : Reel PCB
EGN 2 Photo-Interrupter EGN1006
EGN 3 Photo-Interrupter EGN1006

Miscellaneous Parts List

C 1 CEAL4R7M35
M 1 Motor Unit (Main) EXA1499
M 2 Motor Unit (Sub) EXA1382
HD 1 Head Assy EXA1594
Pickup Unit(Service)(P8) CXX1313

6. ADJUSTMENT

6.1 TUNER, CASSETTE SECTION

● Connection Diagram

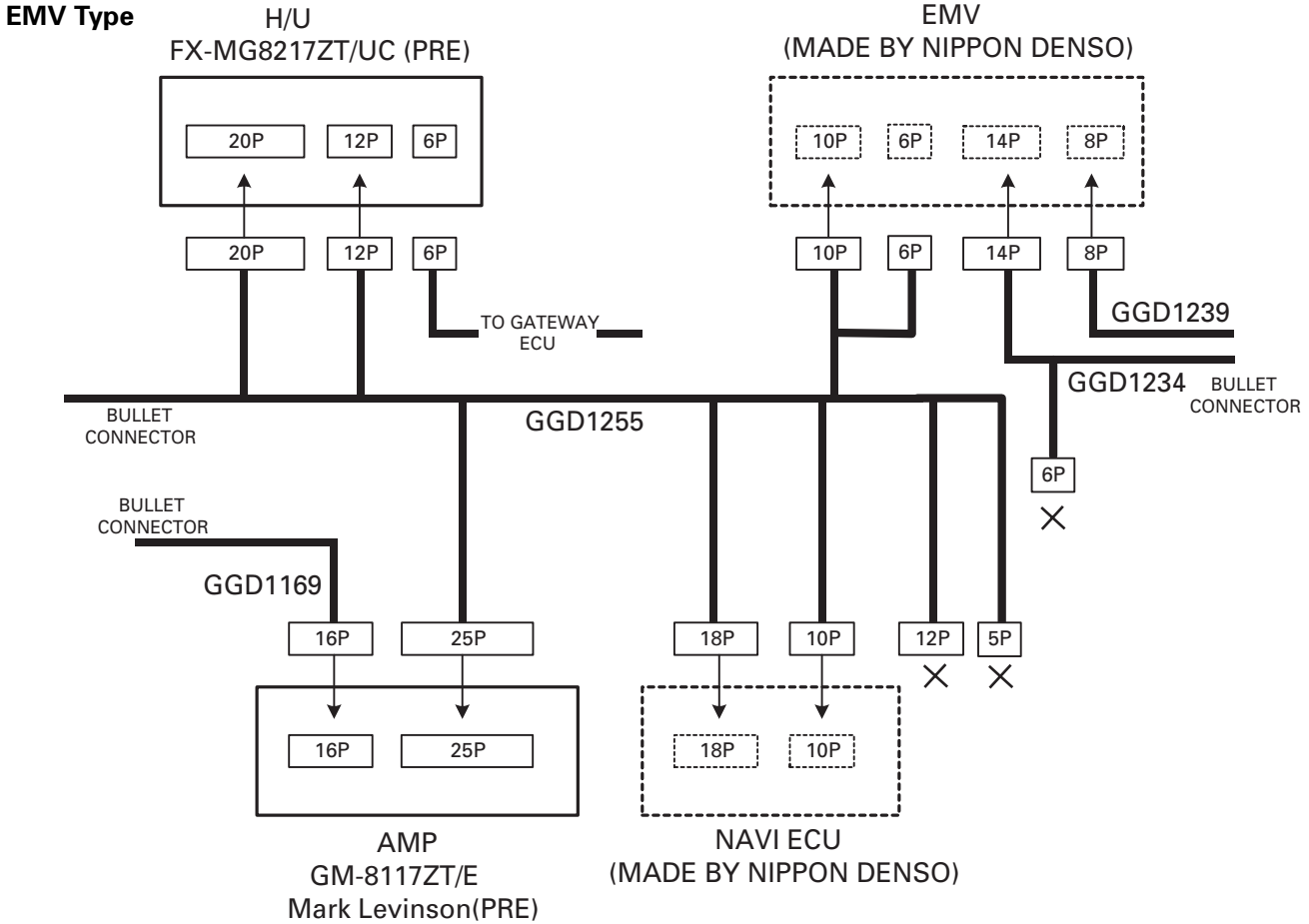

Except for EMV Type

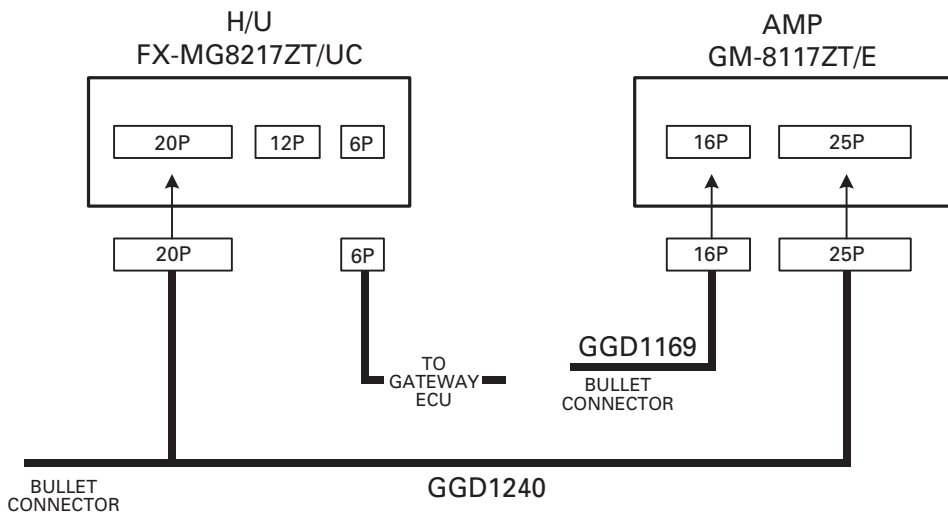

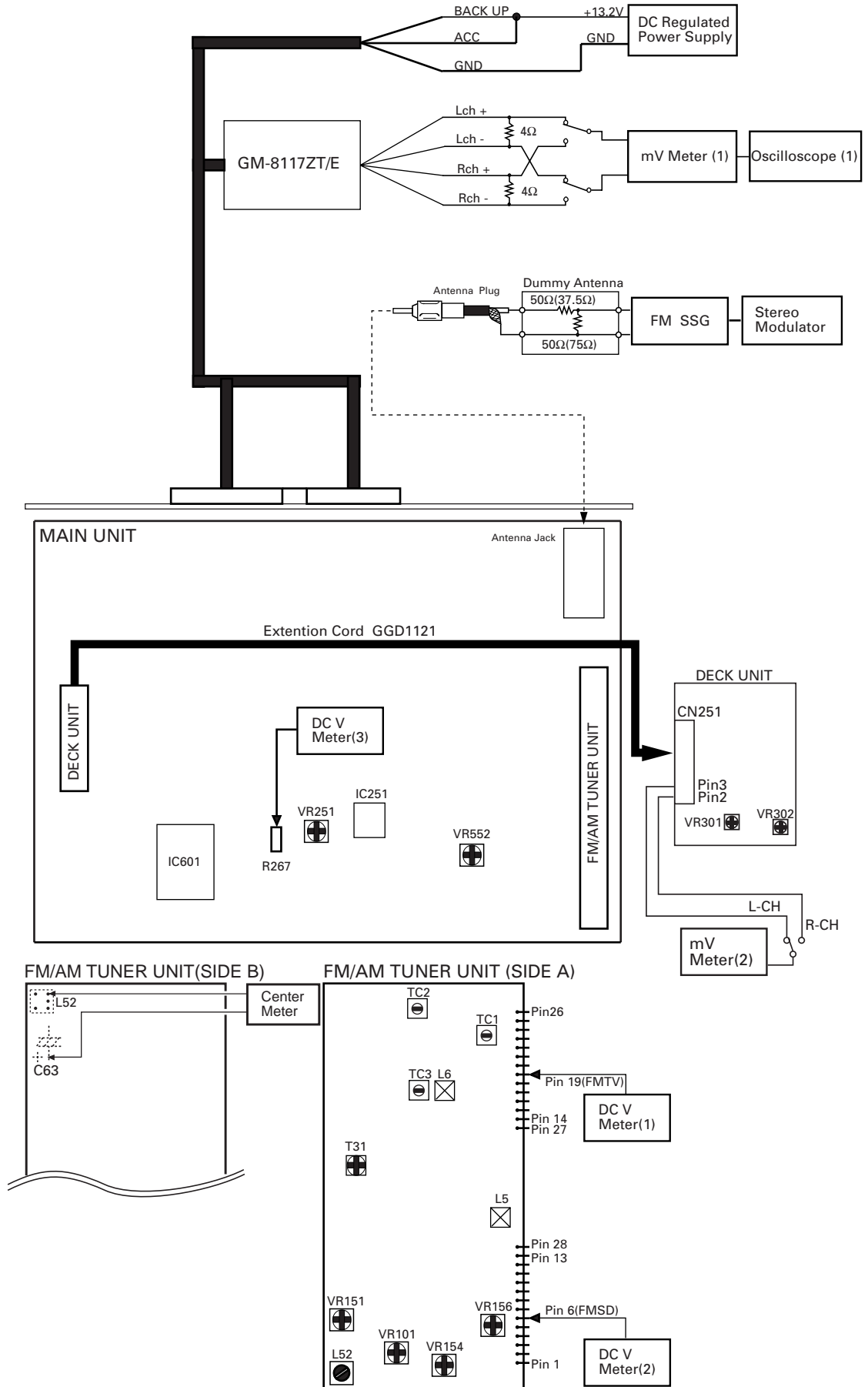

FM ADJUSTMENT

Modulation M: MONO MOD., 400Hz 30%(22.5kHz Dev.)

S1: STEREO MOD., 1kHz, L or R=30%(20.25kHz+7.5kHz Dev.)

S2: STEREO MOD., 1kHz, L or R=60%(40.5kHz+7.5kHz Dev.)

NOTE: Before proceeding to further adjustments after switching power ON, let the tuner run for ten minutes to allow the circuits to stabilize.

	No.	FM SSG		Displayed Frequency(MHz)	Adjustment Point	Adjustment Method (Switch Position)
		Frequency(MHz)	Level(dBf)			
TUN Volt	1	•••••	•••••	107.9	L5	DC V Meter(1) : 6.0V
Center Meter	1	98.1 M	65-85	98.1	L52	Center Meter : 0
IFT	1	98.1 M	5-15	98.1	T31	mV Meter(1) : Maximum
RF Trimmer	1	106.1 M	5-15	106.1	TC3	mV Meter(1) : Maximum
ANT Trimmer	1	98.1 M	5-15	98.1	TC1,TC2	mV Meter(1) : Maximum
RF Coil	1	89.9 M	5-15	89.9	L6	mV Meter(1) : Maximum
RF Trimmer	1	106.1 M	5-15	106.1	TC3	mV Meter(1) : Maximum
RF Coil	1	89.9 M	5-15	89.9	L6	mV Meter(1) : Maximum
RF Trimmer	1	106.1 M	5-15	106.1	TC3	mV Meter(1) : Maximum
Separation	1	98.1 S	65	98.1	VR101	mV Meter(1) : Maximum
ARC Separation	1	98.1 S	38	98.1	VR154	mV Meter(1) : Separation 5dB
Interstation	1	98.1 M	65	98.1	•••••	mV Meter(1) : AdB
Noise	2	98.1 M	-∞	98.1	VR151	mV Meter(1) : A-20dB
Search	1	98.1 M	33	98.1	VR156	DC V Meter(2) : more than 3.5V
Sensitivity	2	98.1 M	32	98.1	VR156	DC V Meter(2) : 0V
	3	Repeat steps 1 and 2 until the adjustment standards are satisfied.				

RBDS SL ADJUSTMENT

	No.	FM SSG		Displayed Frequency(MHz)	Adjustment Point	Adjustment Method (Switch Position)
		Frequency(MHz)	Level(dBf)			
TUN Volt	1	104.1 S2	35	104.1	VR251	DC V Meter(3) : 1.75V+0.05V -0.35V

DOLBY NR ADJUSTMENT

No.	Test Tape	Adjustment Point	Adjustment Method (Switch Position)
1	NCT-150 (400Hz,200nwb/m)	VR301(Lch),VR302(Rch)	mV Meter(2) : -8.24dBm(300mV)±1dB (DOLBY NR Switch : OFF)

AM NOISE CANCELER ADJUSTMENT

Connection:

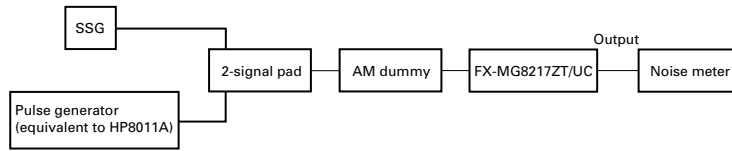

Setting of the pulse generator (setting of superimposed pulse)

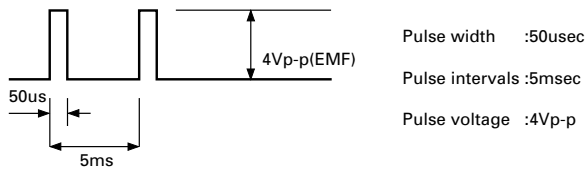

Adjustment:

1. Setting of SSG
 - Receiving frequency : 999 kHz
 - Percentage modulation : 30%
 - Modulation frequency : 400 Hz
 - Antenna input : 74 dBuV (EMF)
2. Set the system as shown in 1., then tune to a radio station.
3. Superimpose the pulse over signal to set modulation of SSG to OFF.
4. Use a noise meter to monitor output. Adjust VR552 to minimize the noise level.

6.2 CHECKING THE GRATING AFTER CHANGING THE PICKUP UNIT

• Note :

The grating angle of the PU unit cannot be adjusted after the PU unit is changed. The PU unit in the CD mechanism module is adjusted on the production line to match the CD mechanism module and is thus the best adjusted PU unit for the CD mechanism module. Changing the PU unit is thus best considered as a last resort. However, if the PU unit must be changed, the grating should be checked using the procedure below.

• Purpose :

To check that the grating is within an acceptable range when the PU unit is changed.

• Symptoms of Mal-adjustment :

If the grating is off by a large amount symptoms such as being unable to close tracking, being unable to perform track search operations, or taking a long time for track searching.

• Method :

- | | |
|-----------------------|----------------------------|
| • Measuring Equipment | • Oscilloscope, Two L.P.F. |
| • Measuring Points | • E, F, REFOUT |
| • Disc | • ABEX TCD-784 |
| • Mode | • TEST MODE |

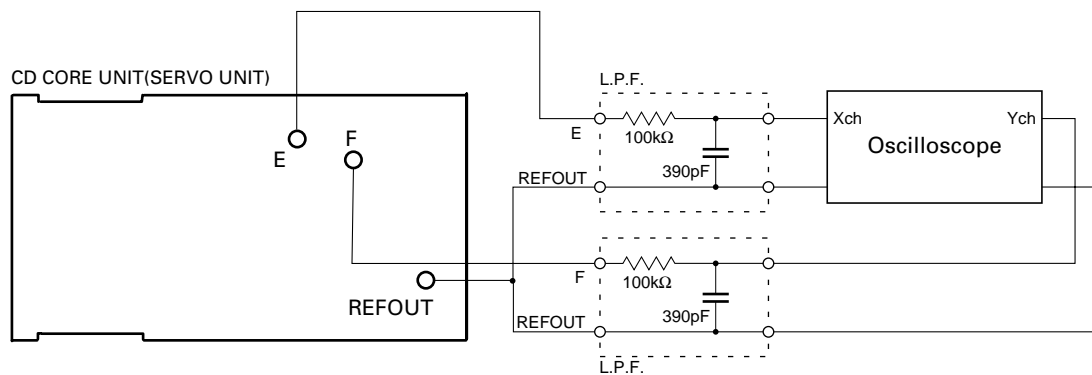

• Checking Procedure

1. In test mode, load the disc and switch the 5V regulator on.
2. Using the SEEK UP and SEEK DOWN buttons, move the PU unit to the innermost track.
3. Press key 5 to close focus, the display should read "91". Press key 3 to implement the tracking balance adjustment the display should now read "81". Press key 5 4 times. The display will change, returning to "81" on the fourth press.
4. As shown in the diagram above, monitor the LPF outputs using the oscilloscope and check that the phase difference is within 75°. Refer to the photographs supplied to determine the phase angle.
5. If the phase difference is determined to be greater than 75° try changing the PU unit to see if there is any improvement. If, after trying this a number of times, the grating angle does not become less than 75° then the mechanism should be judged to be at fault.

• Note

Because of eccentricity in the disc and a slight misalignment of the clamping center the grating waveform may be seen to "wobble" (the phase difference changes as the disc rotates). The angle specified above indicates the average angle.

• Hint

Reloading the disc changes the clamp position and may decrease the "wobble".

Grating waveform

Ech → Xch 20mV/div, AC

Fch → Ych 20mV/div, AC

0°

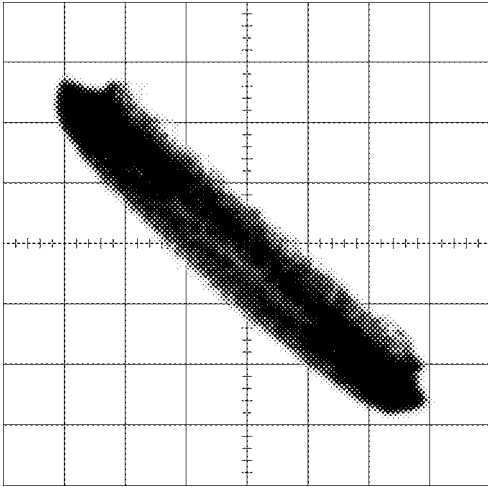

30°

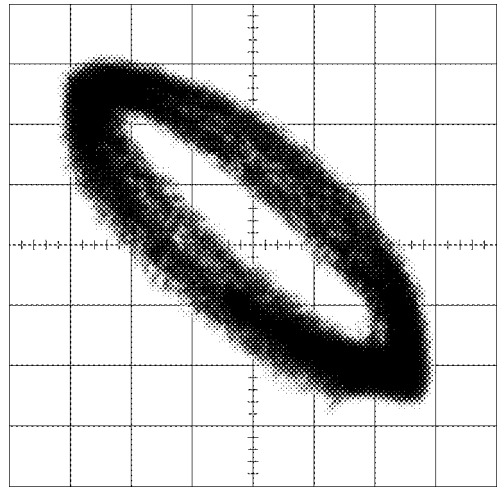

45°

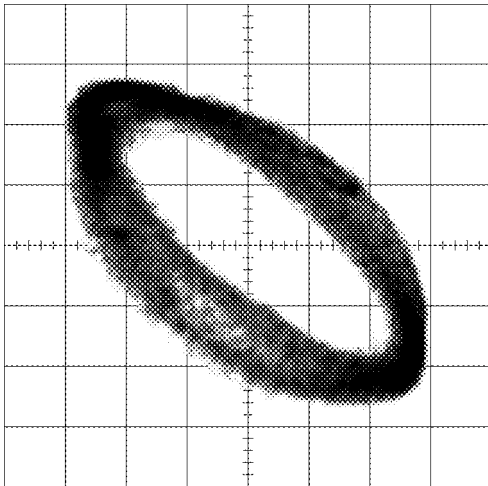

60°

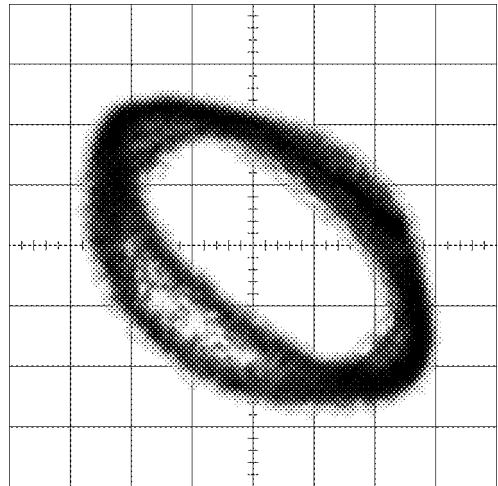

75°

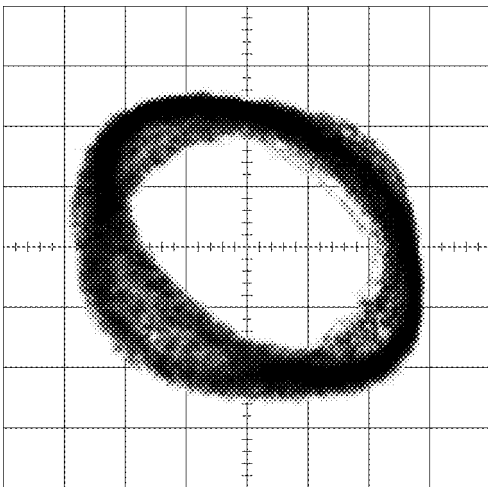

90°

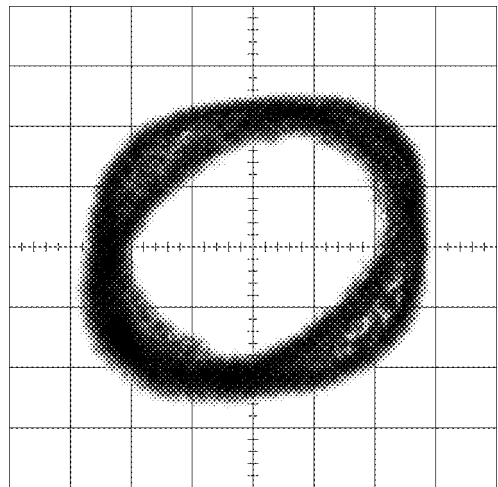

7. GENERAL INFORMATION

7.1 DIAGNOSIS

7.1.1 TEST MODE

● CD Test Mode

1) Precautions on Adjustment

- The unit employs a single voltage (+5V) for the regulator, thus the reference potential of the signal is RFOUT (approximately 2.5V) rather than GND. Inadvertent contact of RFOUT and GND during adjustment can result not only in disabling normal potential measurement but also in exposing the pickup to strong impacts due to malfunctioning of the servo. Therefore, you are requested to observe the following precautions.
- Make sure that the negative probe of the measuring instrument is not connected to RFOUT or GND. Special care must be exercised so that the channel 1 negative probe may not be connected to the oscilloscope and the channel 2 negative probe to GND. Since the frame of the measuring instrument is usually at the same potential as the negative probe, the frame of the measuring instrument must be changed to floating status. When RFOUT is inadvertently connected to GND, you must immediately turn off the regulator or power supply.
- The regulator must be turned off before mounting or dismounting filters or wiring materials.
- You should not start adjustment or measurement immediately after the regulator is turned on. It is recommended to run the player for approximately one minute so that it may stabilize.
- When the test mode is turned on, various protective functions from the software become unavailable. Thus, you must make sure that undesirable electric or mechanical shocks are not be given to the system.
- This model employs a photo-transistor for detecting discs at their loading or ejection. Thus, if its outer case is removed during repair work and internal parts are exposed to light of strong intensity, malfunctions including the following can result:
 - * The eject button becomes inoperable during play. Pressing the eject button does not eject a disc and play is continued.
 - * Loading becomes unavailable.
 If a malfunction is recognized, appropriate remedial actions must be taken. Such actions include changing the light source position, changing the unit position and applying a cover to the photo-transistor.
- When you press the EJECT key to eject a disc, you must not touch any other key until the ejection is complete.
- If you press the SEEK UP or SEEK DOWN for the focus search in the test mode, you must turn the power off immediately. (Otherwise, the lens will be forced to stick to the top or bottom, potentially resulting in the burning of the actuator.)

2) Description of the Test Mode

- Turning on the Test Mode
See page 77.
- Ending the Test Mode
Apply the reset (the reset will be applied two minutes after the power is turned from off).
- Operation of TR JUMPs (except 100TR) continues after your finger has left the key. CRG, MOVE and 100TR JUMP are forced to the tracking close mode as soon as the key is released.
- Turning the power on or off resets the JUMP MODE to the Single TR.

● How to enter the CD Test Mode

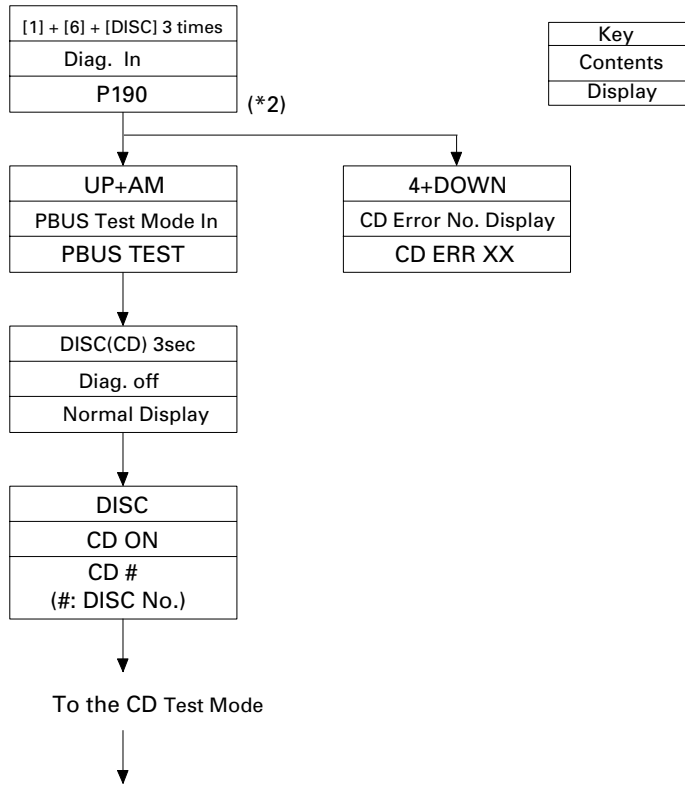

Return to the normal mode by resetting the microcomputer.(*1)

(*1) For canceling test mode, reset the unit.
(*2) No display unit connected

FX-MG8217ZT, MG8217ZT-91

CD Player Flow Chart

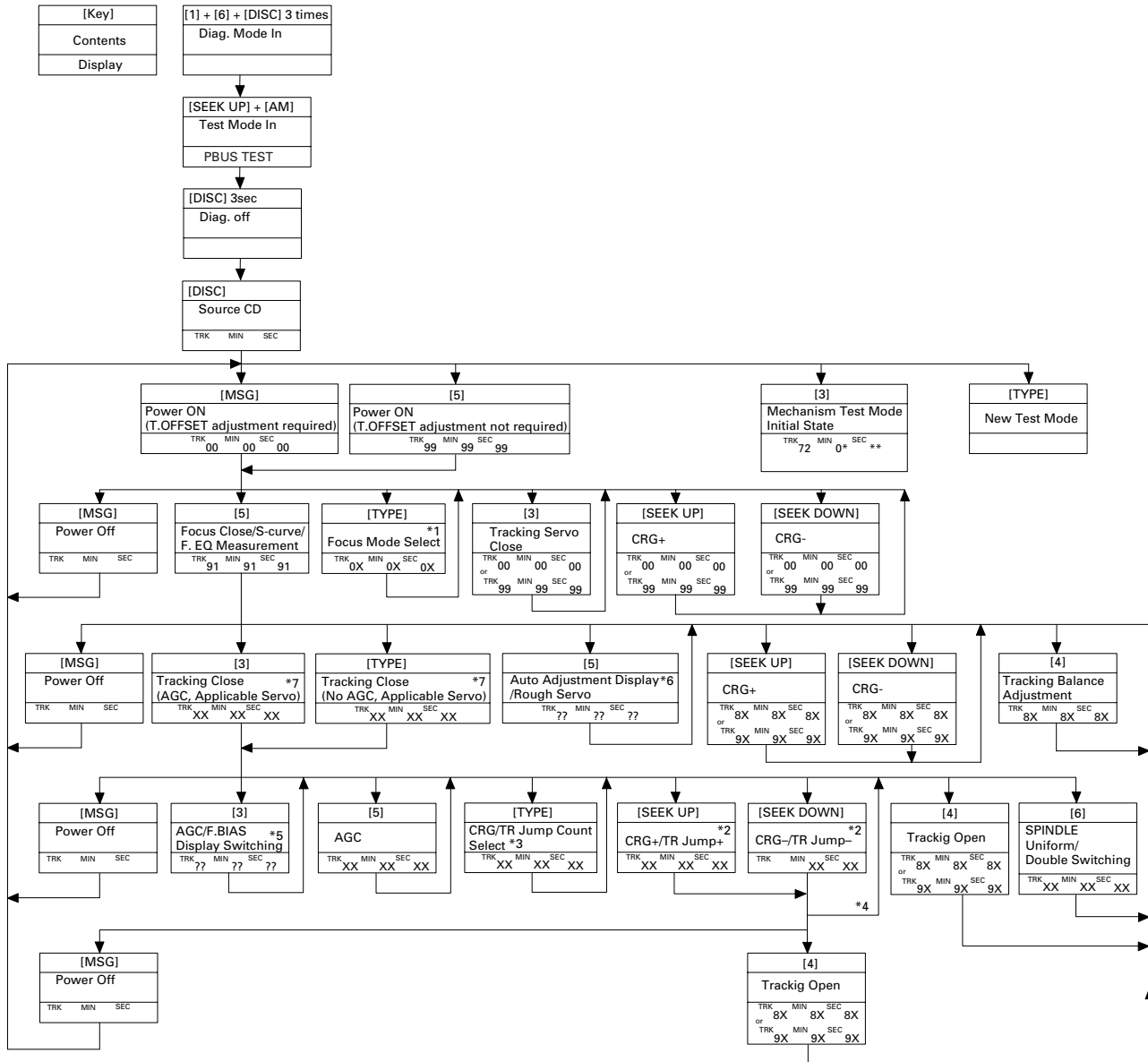

*1) Switching must take place in the following sequence.

Focus Close → S.Curve Check → Focus EQ Measurement.
 MIN_SEC_00 MIN_SEC_01 MIN_SEC_02
 (MIN_SEC_99)

*2) Single TR /4TR / 10TR / 32TR / 100TR

*3) Switching must take place in the following sequence.

Single TR → 4 TR → 10 TR → 32 TR → 100 TR → CRG Move
 9X(8X):91(81) 92(82) 93(83) 94(84) 95(85) 96(86)

*4) It applies to the CRG Move and 100TR Jump alone.

*5) Switching must take place in the following sequence.

Min/Sec (or Track No.) → F.AGC Gain → T.AGC Gain → F. BIAS Setting
 (AGC Gain = (Current value/Initial value) x 20)

*6) Switching must take place in the following sequence.

F.Cancel Display → T.Offset Display → T.Bal Display → Rough Servo.
 (F.Bias value, F.Cancel value, T.Offset value, T.Bal value = (Upper 8 bits of the setting (7F[H] to 80[H] + 128)/4 = 63[D] to 32[D] to 00[D]).

*7) No sound is reproduced even if Tracking Closes, because the STS IC is not controlled during the test mode.

[Key]	Operation	
	Test Mode	New Test Mode
[MSG] B0H	Power ON/OFF	Error occurrence time/Cause display selection
[SEEK UP] B1H	CRG+/TR Jump+ (Toward the outer tracks)	Track+/FF
[SEEK DOWN] B2H	CRG-/TR Jump- (Toward the inner tracks)	Track-/REV
[3] B3H	Tracking Close/AGC gain, F.Bias adjustment value display selection	—
[4] B4H	Auto Tracking Balance adjustment/ Tracking Open	Mode
[5] B5H	Focus Close, S.Curve, F.EQ measurement/ Rough Servo/AGC	—
[6] B6H	Focus Open	RANDOM
[TYPE] B8H	Focus Mode select/Tracking Close/ CRG-TR Jump selection	Auto/Manual selection
[2] A8H	DISC UP	DISC UP
[1] A9H	DISC DOWN	DISC DOWN
[EJECT] D1-D6	DISC Eject	DISC Eject
[LOAD] 61-66	DISC Load	DISC Load

Note: • If [SEEK UP] or [SEEK DOWN] key is pressed during Focus search, turn off the power immediately to prevent the actuator's damage caused by the lens stuck.

- For all TR jumps (except for 100TR jump), the track jump operation continues even after the key is released. For the CRG Move and 100TR jump, the tracking closes at the same time when the key is released.
- With the Power Off/On, the Jump Mode is reset to the Single TR(91).
- To exit from the test mode, reset the unit. (All modes are completely reset about 2 minutes after the Power is turned off.)

● CD Mechanism Test Mode Flow Chart

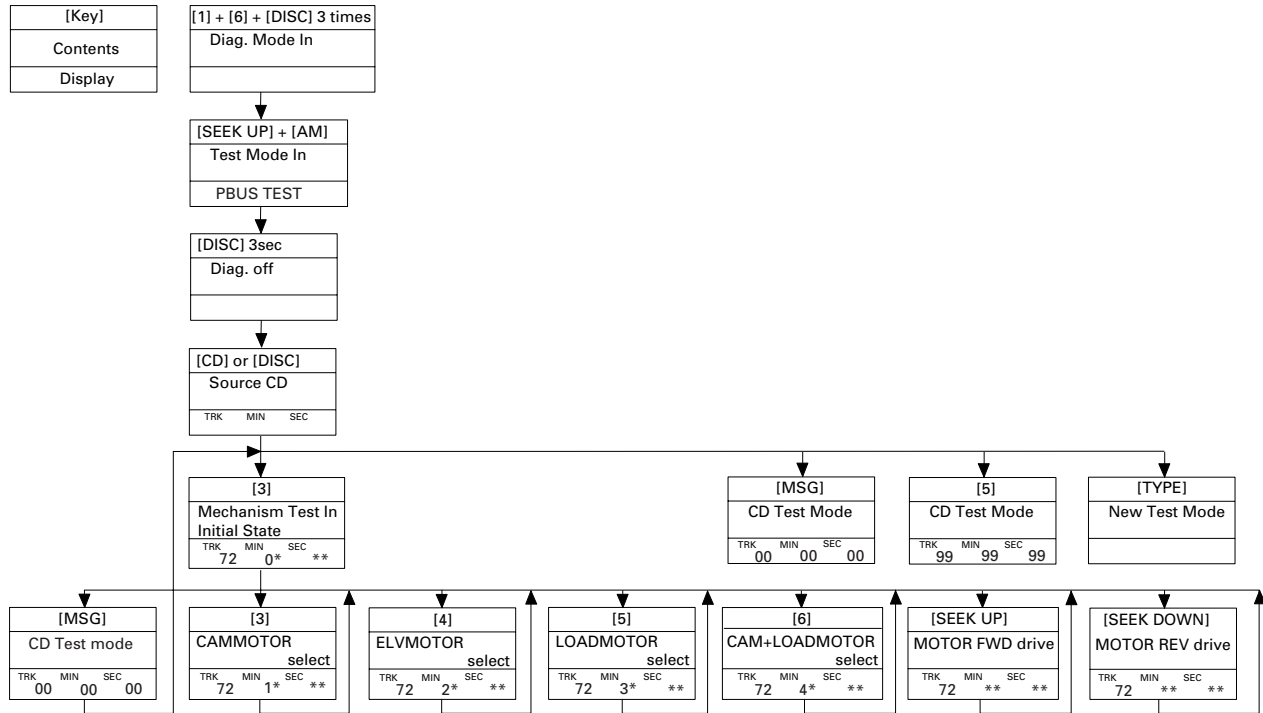

< Display in the Mechanism Test Mode >

TRK: 72

MIN: Upper (10th order): Type of motors selected
 Lower (order of 1): State of DISC sensing phototransistor and switch

- 1* : CAM motor
- 2* : ELV motor
- 3* : LOAD motor
- 4* : CAM+LOAD motors

PH1	PH2	MAXSW	Display
L	L	L	*0
H	L	L	*1
L	H	L	*2
H	H	L	*3
L	L	H	*4
H	L	H	*5
L	H	H	*6
H	H	H	*7

L: Phototransistor is OPEN and switch is ON.
 H: Phototransistor is CLOSE and switch is OFF.

SEC: ① When ELV motor is selected, ELV position is indicated.
 01: ELV home position (Disc 1).
 10: Each Disc position (Disc 2 to 6).
 11: Between Positions
 (The other operations except for ELV are impossible) * Note 1
 00: Not used (Abnormal condition)

② When CAM and LOAD motors selected, the state of the CAM SW (or the CAM gear) is indicated.

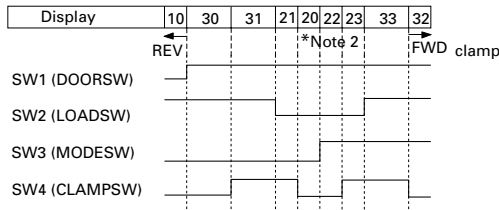

□ Operating Procedures:

- 1) Enter the DIAG mode, turn the CD TEST MODE On, exit from the DIAG mode, then switch the SOURCE to CD.
- 2) Press the [3] key to enter the MECH TEST MODE.
 TRK MIN SEC
 72* X* **
- 3) Press one of the [3] to [6] keys to select the motor to be driven.
 TRK MIN SEC
 72* X* **
- 4) When the [SEEK UP] or [SEEK DOWN] is pressed, the motor selected at Step 3) is driven.

[Key]	Operation
[MSG] B0H	To the Mech Test initial state
[SEEK UP] B1H	Drives the motor selected by [F.7] to [F.10] in the FWD direction. Operative only while the key is pressed.
[SEEK DOWN] B2H	Drives the motor selected by [F.7] to [F.10] for the REV direction. Operative only while the key is pressed.
[3] B3H	Selects the CAM MOTOR.
[4] B4H	Selects the ELV MOTOR.
[5] B5H	Selects the LOAD MOTOR.
[6] B6H	Selects the CAM + LOAD motors.
[2] A8H	DISC UP
[1] A9H	DISC DOWN
[EJECT] 43H	DISC Eject
[LOAD] 60H	DISC Load

□ Cautions

- * During the mech operation, each key input is ignored.
- * When the ELV position is '11'(*Note 1), the other motors cannot be moved.
- * For elevation, the CAMSW should be at the state *Note 2 as shown above. Basically, right after the display for the CAM SW changes from 22 to 20, drive the ELV MOTOR.)
- * When the CAM MOTOR is moved in the REV mode (31 → 30 → 10), the Elevation should be at the EJECT/LOAD position.

○ Operation steps from CLAMP to EJECT

- ① Press the [3] key to select the CAM MOTOR, and drive the CAM MOTOR from the CLAMP position (CAMSW:32) for the REV direction. The CAMSW display changes as 32→33→23→22.
- ② If the disc clamped is not the disc to be ejected, around the shifting point between 22 and 20, press the [4] key to select the ELV MOTOR and to position the elevation to the disc to be ejected. After selecting the ELV MOTOR, first be sure to move the Elevation down (in the REV direction) till the ELV position display shows 01 (Disc 1). When the Elevation is moved upward (in the FWD direction), the first indication of 10 shows the position of Disc 2, and the second indication of 10 shows that of Disc 3. Therefore, you can detect the position of the elevation by counting the number of the indication '10'. (Ex: When the elevation moves from Disc 1 to Disc 6, the display changes as follows:01→11→10→11→10→11→10→11→10→11→10.) (If the disc to be ejected has been clamped, step ② is not necessary.)
- ③ Press the [3] key to select the CAM MOTOR, drive the CAM MOTOR in the REV direction till the indication changes from 20 (or 22) to the shifting point between 21 and 31.
- ④ Press the [4] key to select the ELV MOTOR, and move the tray for the disc to be ejected to the EJECT/LOAD position (in the FWD direction). (When the elevation is positioned at the top after moving in the FWD direction (the indication: 10), this is called the EJECT/LOAD position.)
- ⑤ Press the [6] key to select the CAM+LOAD MOTORS, and move the motor in the REV direction until the display changes from 31 to the shifting point between 30 and 10. When the display becomes 10, the door opens and the disc is slightly pushed out.
- ⑥ When the display becomes 10, press the [5] key to select the LOAD MOTOR. Drive the motor in the REV direction to eject the disc completely.

● Error No. Display

The error mode is turned on if a CD player becomes not playable or is forced to halt due to an error. Cause(s) of an error will be indicated with numerical characters. The error-number-display function is intended to facilitate the error analysis and resulting repair work.

(1) Error Code

Error code	Category	Troubles	Description/Cause(s)
10	Electricity	Carriage home error	Unable to move to or from inner perimeter → Failure on home switch or carriage move trouble.
11	Electricity	Focus search error	Unable to set a focus → Scratches or stains on backside of the disc, severe vibrations, CD-R is not written to the disc (it can happen on the backside of the disc).
12	Electricity	Spindle lock error Sub-code error	Spindle lock unavailable, sub-code unreadable → Failure on spindle, scratches on the disc, stains or strong vibrations.
14	Electricity	Mirror error	MIRR signal error continues for 500 msec or more → Stains on the disc or strong vibrations.
17	Electricity	Setup error	AGC protection cannot be turned on in time or focus can be easily lost → Scratches or stains on the disc or strong vibrations.
19	Electricity	Tracking Balance error	Tracking error level is low or tracking balance adjustment is unavailable → Failure on the pickup or tracking-error circuit.
30	Electricity	Search time-out	Target address can't be reached → Failure on the carriage/tracking or scratches on the disc.
A0	System	Error on power supply	Ground fault of power supply (VD) → Failure on switching transistor or failure of power supply.

Error code	AVC-LAN Error code
11, 12, 14, 17, 19, 30	ERROR1
10	ERROR3
A0	ERROR4

Code	Name	Description
20	Door OPENING	While the mechanism is in operation, should have been closed a door was opened.
21	Roller OFF time-out	4 seconds have elapsed before completing the roller OFF (the cam gear has not been rotated to the roller-OFF end position).
22	Roller SET time-out	4 seconds have elapsed before completing the roller SET.
	(Roller OFF time-out)	(During the roller OFF operation, 4 seconds have elapsed while the cam gear is rotating in REV direction.)
23	Door CLOSING	Door can't be closed when the roller OFF has ended.
24	Cam started from invalid position	The cam gear attempted to do roller OFF/roller SET from an invalid position.
26	Foreign substance on photo-transistor (before closing the door)	Foreign substance was found on the photo-transistor when closing the door after the loading is complete. An error will be indicated if the disc is still caught by the photo-transistor after 4 seconds of forced eject.
29	Roller being caught	Although the cam gear has been rotated up to the roller OFF end position, the roller can't be moved to the standby position.
41	Lift DOWN time-out	4 seconds have elapsed before completing the lift DOWN operation.
42	Lift UP time-out (Lift DOWN time-out)	4 seconds have elapsed before completing the lift UP operation. (During the lift DOWN operation, 4 seconds have passed with the cam gear rotating in REV direction.)
45	Lift DOWN cam displacement	The lift DOWN complete cam gear has been displaced from its specified position.
52	EJECT time-out	8 seconds have elapsed before completing the EJECT operation. An error will be indicated if the disc is still caught by the photo-transistor after 4 seconds of forced eject.
57	Photo-transistor being caught after forced EJECT	When forced eject was employed for the Bup failure during loading or ejection, an error will be indicated if the disk is still caught by the photo-transistor after 4 seconds of forced eject.
61	CRGIN time-out (CRGOUT time-out)	10 seconds have elapsed before completing CRGIN operation. (During CRGOUT operation, 10 seconds have elapsed with the cam gear rotating in REV direction.)
62	CRGOUT time-out	10 seconds have elapsed before completing the CRGOUT operation.
65	CRGOUT cam displacement	Position of the CRGOUT complete cam gear has been displaced.
71	ELVUP time-out	2 seconds have elapsed before completing 1-stage UP.
72	ELVDN time-out	2 seconds have elapsed before completing 1-stage DOWN.
74	ELV displacement	At the start of ELV, ELVSNS was not set to low. (In case of starting from the 1st floor, ELHOME was not set to low.)
75	ELV counting error	HLHOME was set to low though not on the 1st floor. (There is a conflict between the floor number stored on the microcomputer and the actual floor number.)
91	LOAD time-out	8 seconds have elapsed before completing the LOAD. An error will be indicated if the disc is still caught by the photo-transistor after 4 seconds of forced eject.
96	Settlement of foreign substance	Unauthorized foreign substance such as 8 cm disc has been loaded. An error will be indicated if the disc is still caught by the photo-transistor after 4 seconds of forced eject.

* AVC-LAN Error code : ERROR3

7.1.2 DISASSEMBLY

● **Removing the Case (Fig.1)**

1 Remove the four screws and then remove the Case.

● **Removing the Grille Assy (Fig.1)**

2 Remove the two screws.

Disconnect the connector and then remove the Grille Assy.

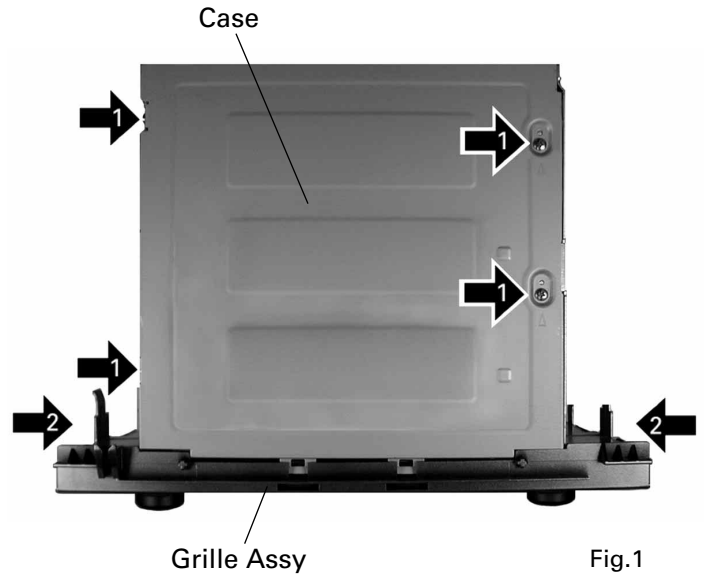

● **Removing the Chassis (Fig.2)**

1 Remove the eleven screws and then remove the Chassis.

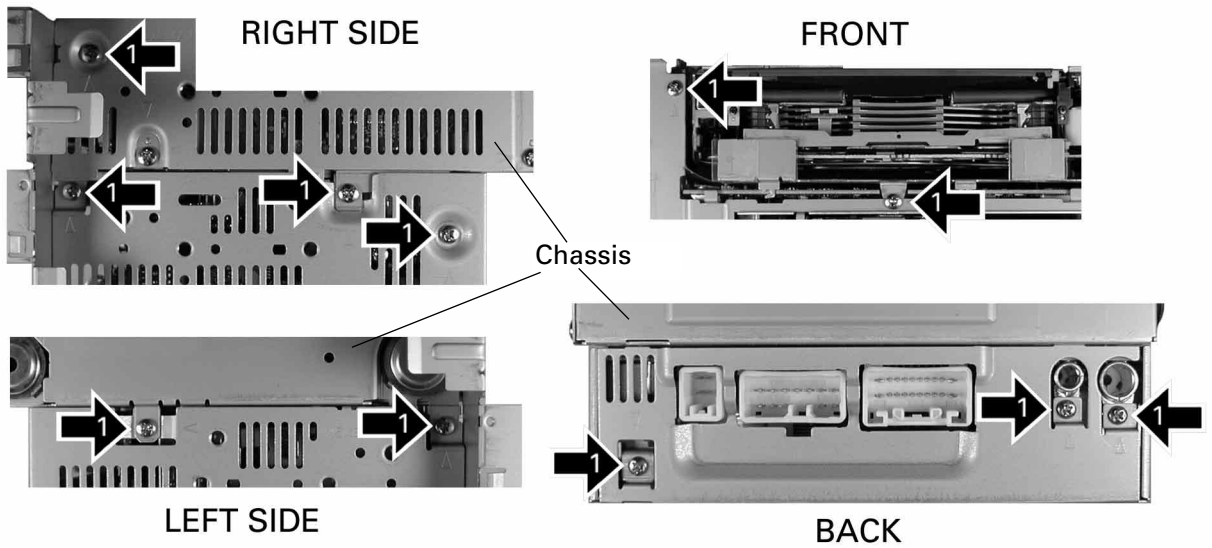

● **Removing the Cassette Mechanism Module (Fig.3)**

- ➔ 1 Remove the four screws and then remove the Cassette Mechanism Module.

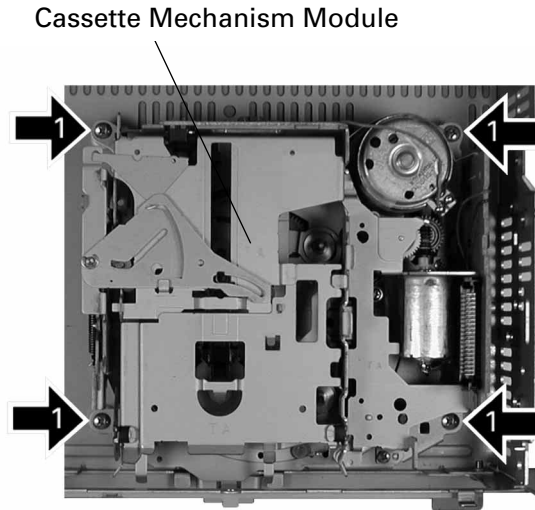

Fig.3

● **Removing the Control Unit (Fig.4)**

1. Unbend the tabs at two locations indicated by arrows until straight.
2. Remove the screw F.
3. Disconnect the two connectors, and then remove the Control Unit.

● **Removing the Mechanism Unit (Fig.4)**

1. Remove the five screws G, and then remove the four Holders and four Dampers.
2. Remove the two springs A, spring B spring C, and four tubes from the hock.
3. Remove the Mechanism Unit from the Chassis.

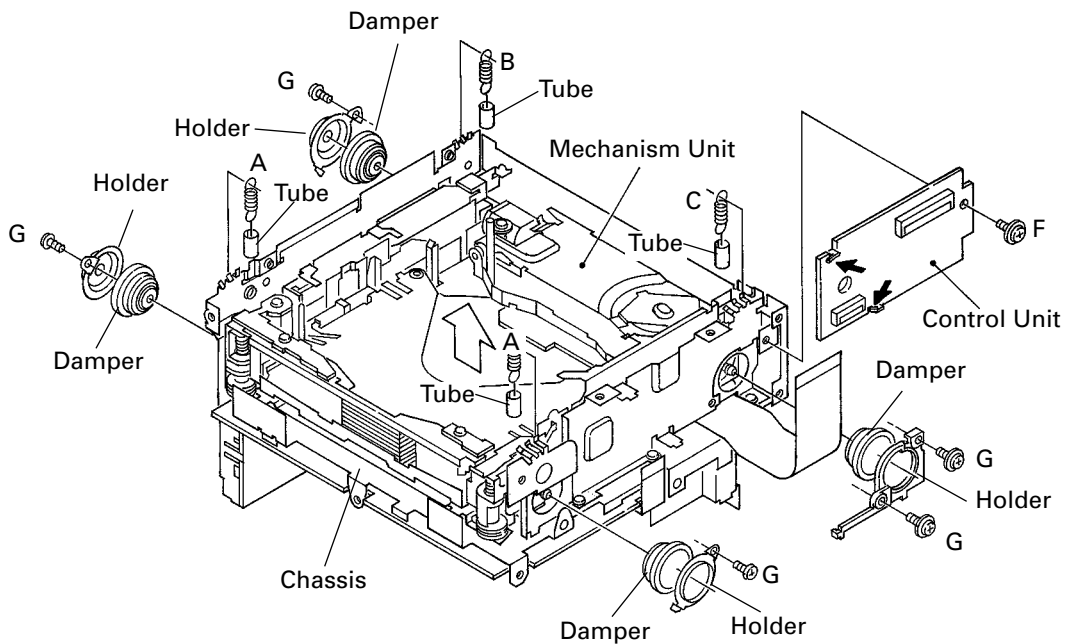

Fig.4

● **Removing the Main Unit (Fig.5)**

- ➔ **1** Straight the tabs at four locations indicated.
- ➔ **2** Remove the screw and then remove the Main Unit.

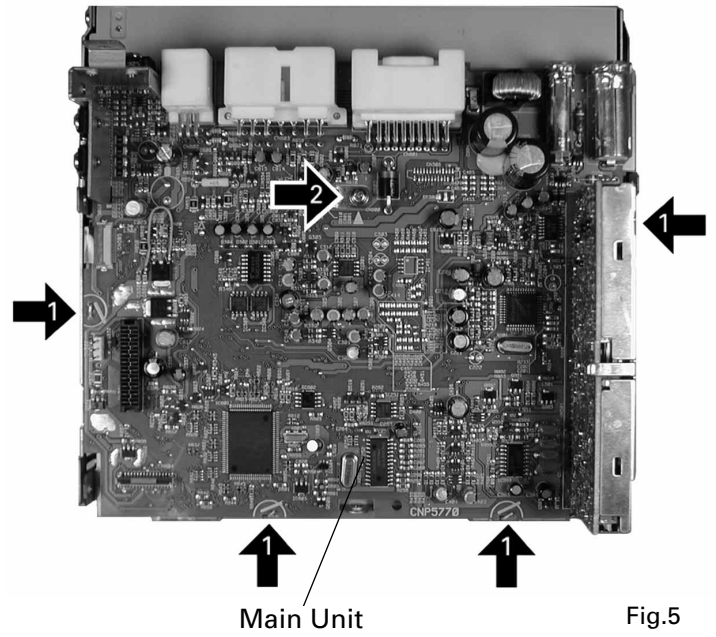

Fig.5

● **How to remove the Tray Assy**

- 1. Apply about 6V current to the Cam gear motor until all holes match at the position (A) (elevation OK position).
- 2. Hook the three springs B temporarily as shown in Fig. 6. While pushing the Tray holder lock arms (right and left) in the direction (C), remove the Tray holder.

3. Lift up the Tray assy to remove it.

* Be careful not to remove the Tray hooks from the Tray assy.

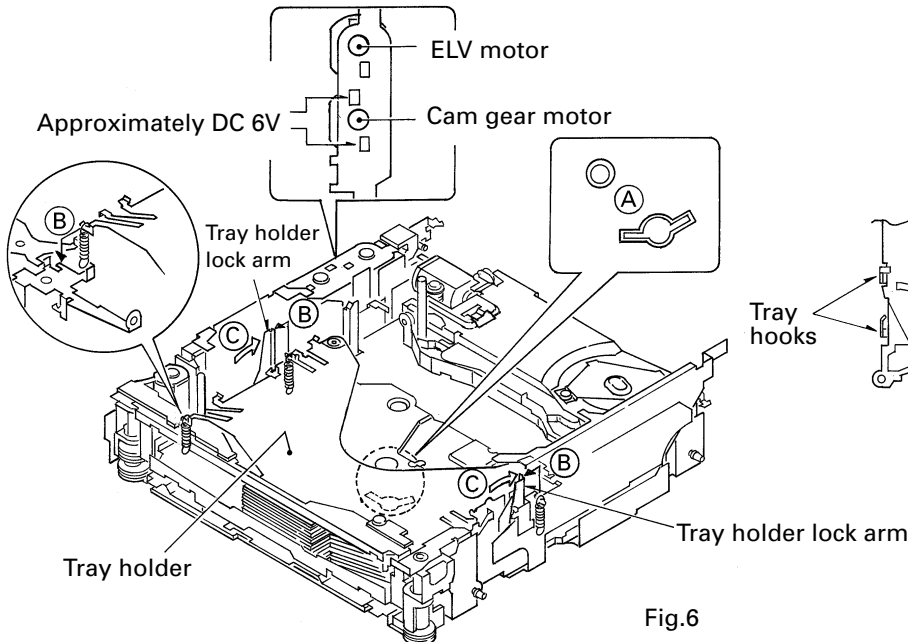

Fig.6

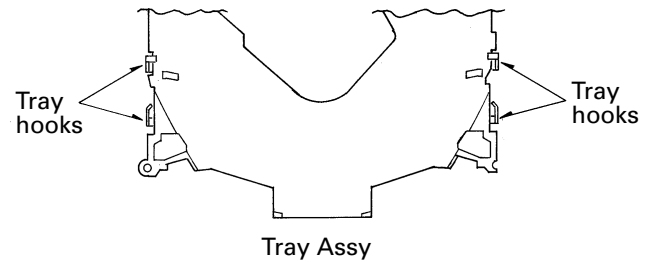

Fig. 7

● **How to remove the Carriage Mech Assy**

1. Insert a short pin into the flexible PCB of the Pickup unit.
2. While opening the resin hooks, remove the cover from the Servo unit.
3. Disconnect the flexible PCBs from the connectors CN101 and CN301.
4. Remove the Tray holder and the Tray assy. (See above)
5. Rotate the Cam gear motor until the positions of all holes (E) match, then stop the motor.
(The Carriage Mech assy will stop as shown in the Fig.8.)

- * When the positions of all holes match, they will be completely covered by the Carriage mech assy.
 - * To rotate the Cam Gear motor, see "How to remove the Tray assy".
6. Unhook the spring A.
 7. Remove the flexible holder B (while opening the hooks).
 8. Remove the flexible PCB (C) from the motor. (The flexible PCB (C) has been stuck on the motor with double-sided adhesive tape.)
 9. Loosen the fixing screw and remove the flexible holder.

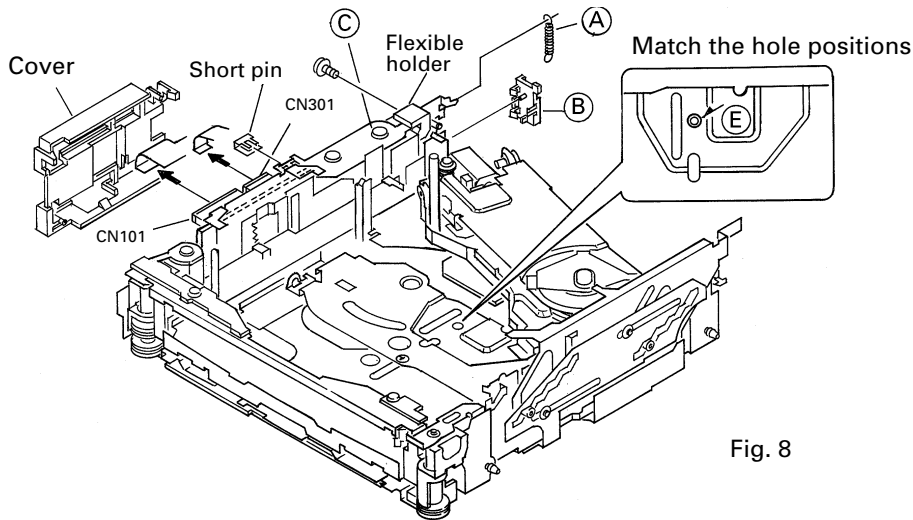

Fig. 8

10. Remove the screw, pressure spring and collar. Lift up the Carriage mechanism assy to remove it.
* Screw tightening torque: 2.6kgfcm

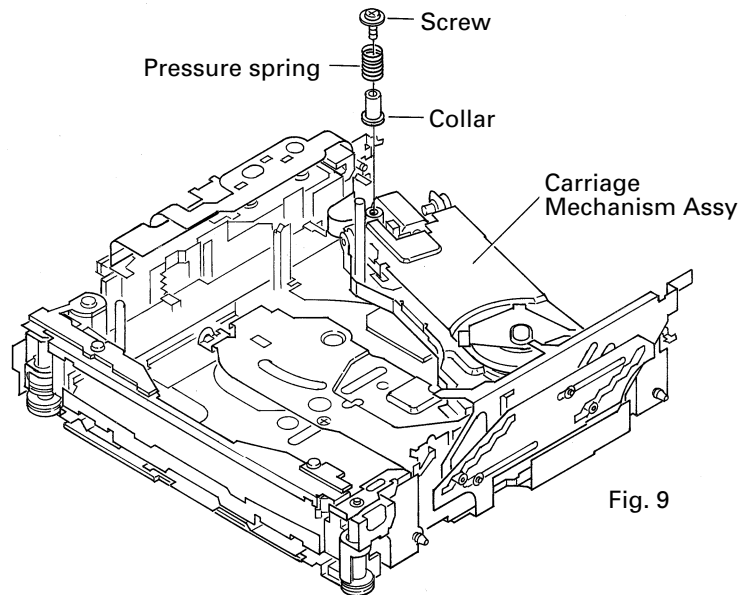

Fig. 9

● **How to remove the Pickup unit**

1. Remove the pulling spring, torsion spring and E-shaped ring. Then remove the Clamper arm.

* The spring (A) will be removed with the Clamper arm.

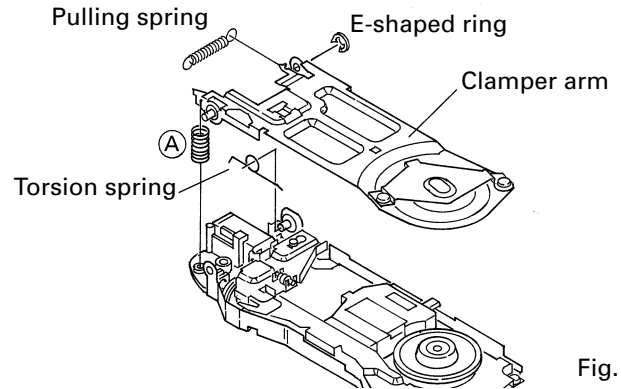

Fig. 10

2. Slide the Clamp UP lever (B) to remove it.
3. Loosen the 2 screws. Remove the feed-screw cover by sliding it.
4. Remove the feed-screw pressure spring (D).
5. Loosen the 2 screws. Remove the feed-screw holder (E).
6. Remove the belt.

7. Remove the Pickup unit together with the feed screw.

* Be careful not to lose the shaft holders at the both ends of the feed screw.

* Be careful not to damage the 2 flexible PCBs (for the Pickup and motor) when separating them. The flexible PCBs have been stuck each other with double-sided adhesive tape.

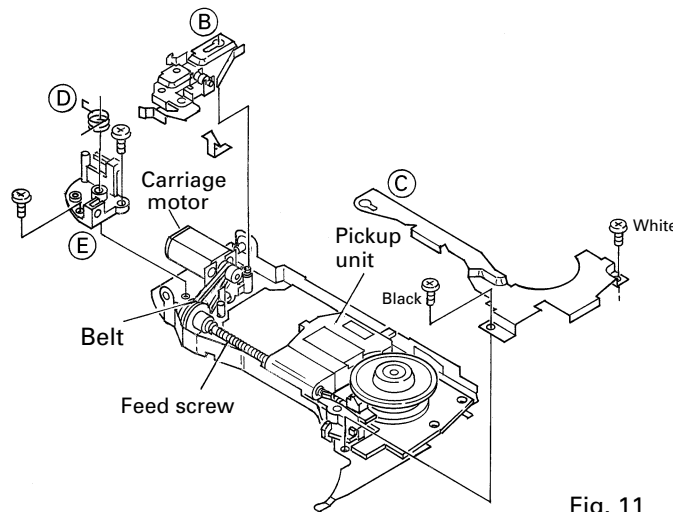

Fig. 11

8. Loosen the 2 screws. Remove the plate spring and the rack.
9. Pull out the feed screw from the Pickup unit.

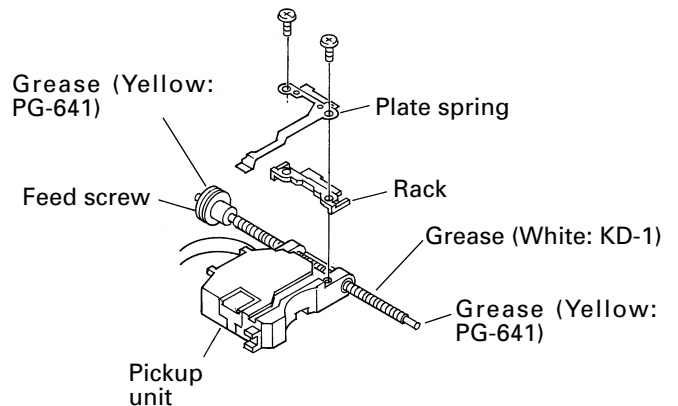
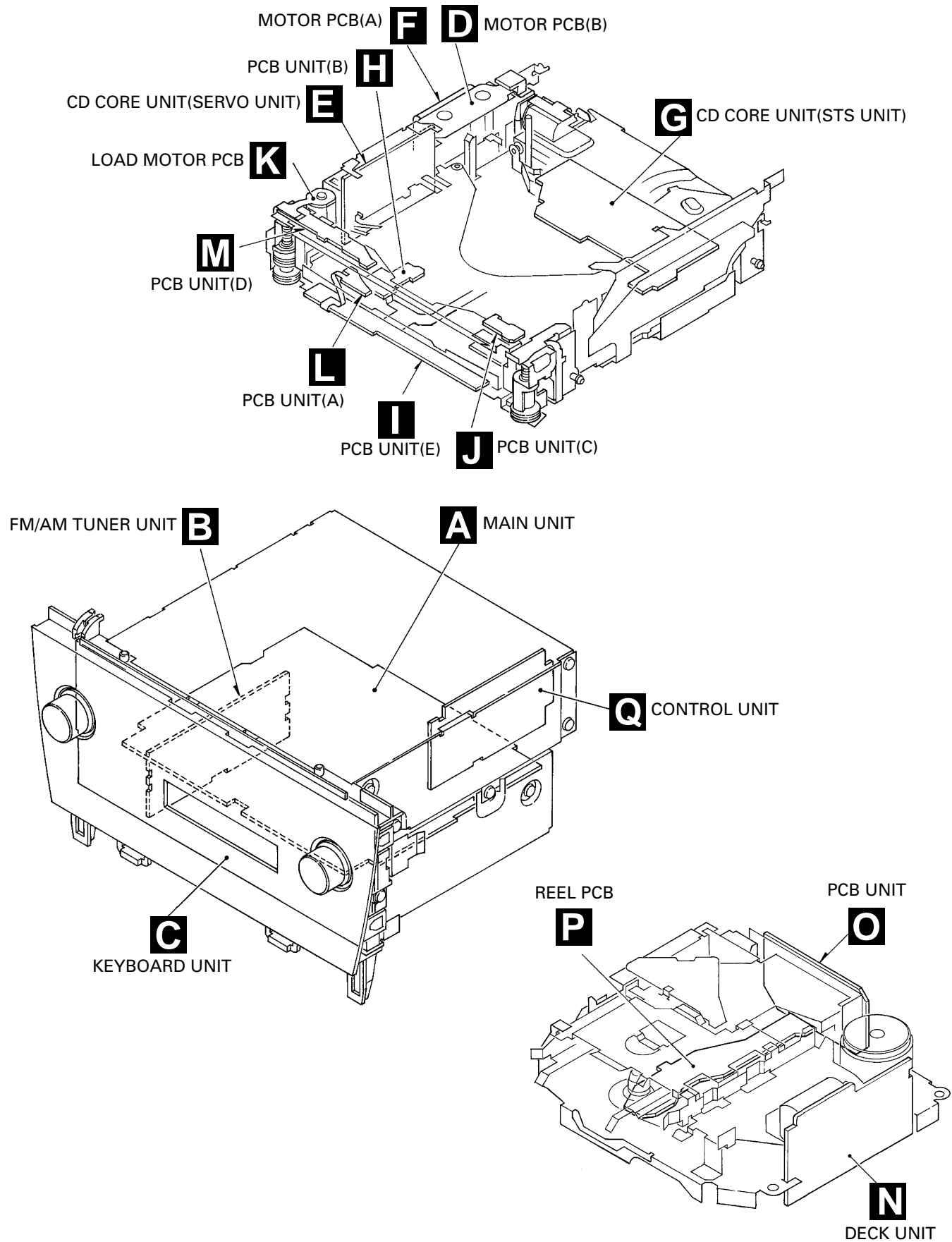
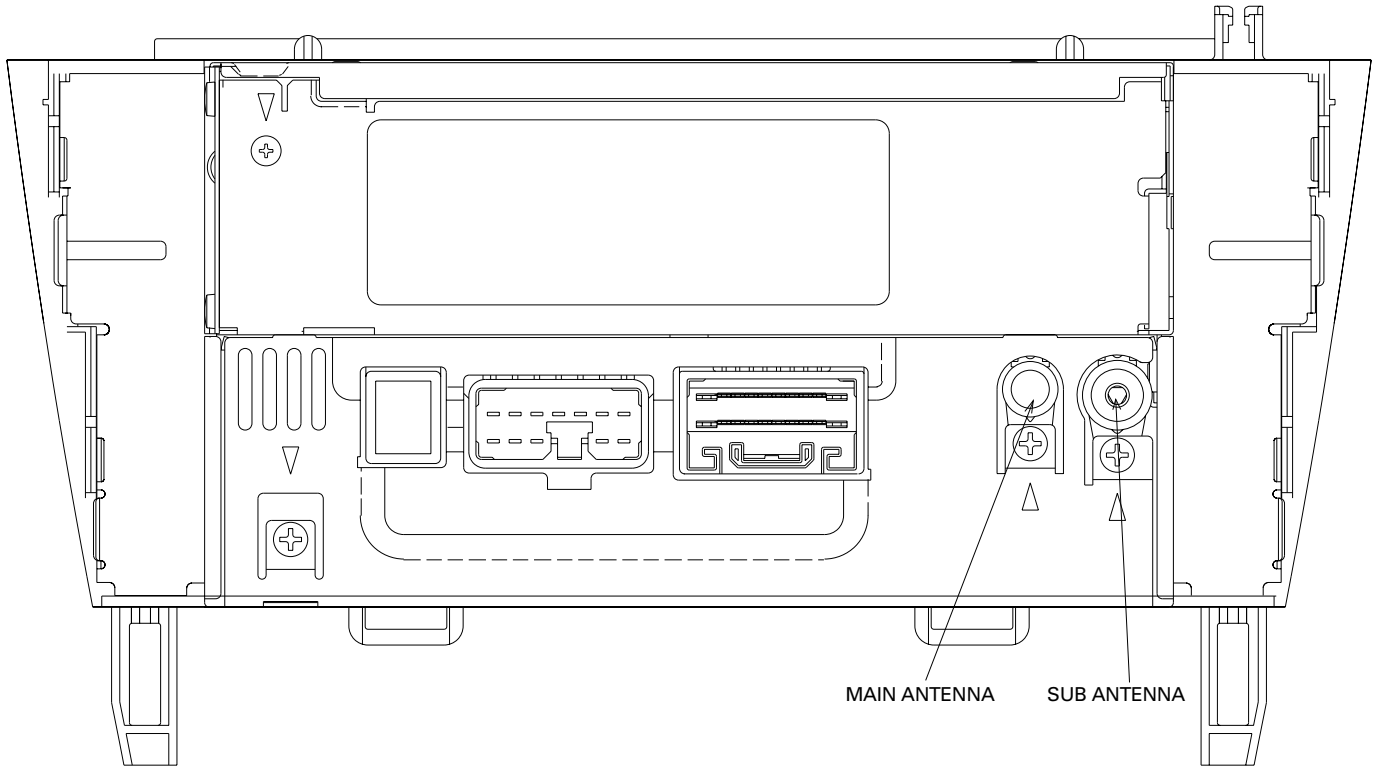

Fig. 12

7.1.3 PCB LOCATIONS



7.1.4 CONNECTOR FUNCTION DESCRIPTION



ANTB		TXS+
ANTA	DOS1	TXS+

R-	L-	GND	TXM-	TXM+		ACC
R+	L+	SGND			MUTE	+B

ACC	ILL-	ANT		TX-		R-	L-	GND	
+B	ILL+			TX+		MUTE	R+	L+	SGND

7.2 PARTS

7.2.1 IC

● Pin Functions (PD5569A)

Pin No.	Pin Name	I/O	Function and Operation
1	SL	I	SD level input from tuner
2	MDSN	I	Modulation level input
3	RDSLK	I	RDS LK signal input
4	LAMP	O	Lamp power supply control output
5	LDO	O	LCD driver data output
6	LDI	I	LCD driver data input
7	LCK	O	Clock output for LCD driver
8	BYTE	I	Connect to VSS
9	CNVSS	I	Connect to VSS
10,11	NC		Not used
12	RESET	I	Reset input
13	XOUT	O	Crystal oscillating element connection pin
14	VSS		GND
15	XIN	I	Crystal oscillating element connection pin
16	VDD		Power supply terminal
17	NMI		Not used
18	RCK	I	RDS clock input
19	LDET	I	PLL lock sense input
20	CDEJ	I	CD eject key sense input
21	RX2	I	IE-BUS data input
22	IPPW	O	IP-BUS driver power supply output
23	ILSENS	I	Illumination sense input
24	DRST	O	RDS decoder reset output
25	57K	I	57kHzBP-OUT sense input
26	CURRO	O	Tuner voltage FIX output
27	SK	I	SK signal input
28	BLIGHT	O	Back light power supply ON/OFF output
29	RX1	I	IE-BUS data input
30	TX	O	IE BUS data output
31	PDO	O	Data output for PLL IC
32	PDI	I	Data input from PLL IC
33	PCK	O	Serial clock output for PLL IC
34	PCE	O	Chip enable output for PLL IC
35	BSO	O	P-BUS serial data output
36	BSI	I	P-BUS serial data input
37	BCK	O	P-BUS serial clock output
38	BRXEN	I/O	P-BUS reception enable input/output pin
39	BRST	I	P-BUS reset input
40	BSRO	O	P-BUS service request output pin
41	ANTPW	O	Antenna power supply control output
42	RDT	I	RDS demodulation data input
43	FMPW	O	FM power supply control output
44	AMPW	O	AM power supply control output
45	SWVDD	O	Keyboard unit power supply control output
46	MW	O	MW/LW select output (not used)
47	SFIX	O	Sub antenna fix output
48	ANSW	O	Analog switch control output
49	CDILL	O	CD illumination output
50	TAPMUTE	O	TAPE mute output
51	MUTE	O	BUS mute output
52	SYSPW	O	System power control output
53	SYSMUTE	O	System mute output
54	POWER	I	POWER key input
55	ENC1+	I	VOL encoder (+) input
56	ENC1-	I	VOL encoder (-) input
57	MODE	I	AUDIO mode key input
58	ENC2+	I	AUD encoder (+) input

Pin No.	Pin Name	I/O	Function and Operation
59	ENC2-	I	AUD encoder (-) input
60	DLOAD	I	CDM load key input
61	ILL	O	LAMP power supply control output
62	VCC		Power supply terminal
63	RECIVE	O	During RDS data reception output
64	VSS		GND
65	RDSMT	O	RDS mute output
66	AMMUTE	O	AM mute output
67	FMMUTE	O	FM mute output
68	DOS	I	Door switch input
69	MS	I	Music sense input
70	FR	O	Cassette mechanism head forward/reverse select output
71	PLAY	O	MS gain select output
72	MTL	I	Cassette mechanism tape select input
73	ASENS	I	ACC power sense input
74	CSEJ	I	Tape eject sense input
75	BSENS	I	Back up power sense input
76	NR	O	Dolby NR ON/OFF select output
77	CSLOAD	I	Tape loading detect input
78	POS	I	Cassette mechanism position sense input
79	RES	I	Cassette mechanism reverse end sense input
80	NES	I	Cassette mechanism forward end sense input
81	TEST	I	Test mode input
82	SC2	O	Cassette mechanism sub motor control 2 output
83	SC1	O	Cassette mechanism sub motor control 1 output
84	CM	O	Cassette mechanism capstan motor control output
85	STBY	O	Cassette mechanism driver stand-by output
86	LRST	I	LCD driver reset output
87	LCE1	O	Chip enable output pin for LCD driver 1
88	LCE2	O	Chip enable output pin for LCD driver 2
89	ST	I	FM stereo input
90	FMSD	I	FM SD input
91	NL	I	Noise level input
92	CL	I	RDS tune off sense input
93	RDSL		RDS signal level
94	ANT0	O	Antenna control A output
95	NC		Not used
96	AVSS	I	A/D converter GND
97	ANT1	O	Antenna control B output
98	VREF	I	A/D converter reference voltage input
99	AVCC		A/D converter power supply
100	LOFF	O	LCD driver inhibit output

*PD5569A

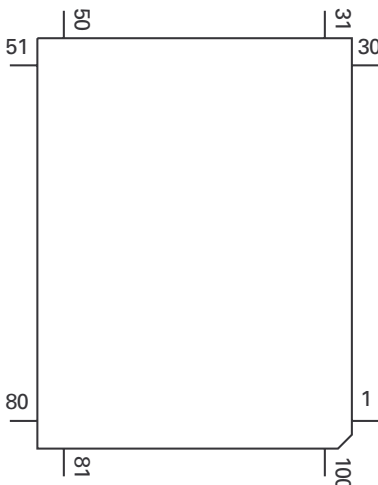

IC's marked by* are MOS type.

Be careful in handling them because they are very liable to be damaged by electrostatic induction.

Format	Meaning
C	C MOS

● Pin Functions (PD5575B)

Pin No.	Pin Name	I/O	Format	Function and Operation
1	VDIN	I		Power supply short sensor input
2	DOORSW	I		Door open position SW input
3	NC			Not used
4	BSRQ	O	C	P-BUS service request output
5	CLAMP	I		DISC clamp SW input
6	ELHOME	I		ELV reset position SW input
7	XSCK	O	C	CD LSI clock output
8	XSO	O	C	CD LSI data output
9	XSI	I		CD LSI data input
10	XSTB	O	C	CD LSI strobe output
11	XRST	O	C	CD LSI reset output
12	XA0	O	C	Control signal distinguishing data from microcomputer
13	VDCONT	O	C	VD control output
14	NC			Not used
15	BSENS	I		Back up power sense input
16	BRXEN	I/O	C	P-BUS reception enable input/output
17	LOADSW	I		Loading position SW input
18	MODESW	I		ELV OK position SW input
19	BSCK	I/O	C	P-BUS serial clock input/output
20	BSO	O	C	P-BUS serial data output
21	BSI	I		P-BUS serial data input
22	BRST	I		P-BUS reset input
23	SBSY	I		Signal indicating head of subcode block
24	CNVSS	I		GND
25	RESET	I		Reset input
26	POWER	O	C	Servo/Mechanism power supply control output
27	CONT	O	C	Servo driver output control
28	Xin	I		Crystal oscillating element connection pin
29	Xout	O	C	Crystal oscillating element connection pin
30	VSS			GND
31-38	NC			Not used
39	TESTIN	I		Chip check program mode input
40	DCLOSE	I		Door close sense input
41	WDSL	O	C	Data comparison area specification signal output
42	XWIH	I		Data write inhibit input
43	XEMP	I		Data read inhibit input
44	CHDT	I		Data comparison mode monitor input
45	CHM0	O	C	Data comparison mode output 0
46	CHM1	O	C	Data comparison mode output 1
47-49	NC			Not used
50	XWRE	O	C	DRAM WRT ENBL
51	XRDE	O	C	DRAM READ ENBL
52	XQOK	O	C	SUB-Q OK output
53	EMPH	O	C	DAC emphasis output
54	SCONT	O	C	Mode select output
55	LOAD	O	C	PHOT power supply control
56	CDMUTE	O	C	CD mute output
57	LO2	O	C	LOAD motor control terminal output 2
58	LO1	O	C	LOAD motor control terminal output 1
59	ELV2	O	C	ELV motor control terminal output 2
60	ELV1	O	C	ELV motor control terminal output 1
61	CG2	O	C	CAM motor control terminal output 2
62	CG1	O	C	CAM motor control terminal output 1
63	MIRR	I		CD LSI mirror detector input
64	LOCK	I		CD LSI spindle lock detector input
65	FOK	I		CD LSI FOK signal input
66-68	NC			Not used
69	ADENA	O	C	A/D reference voltage output

Pin No.	Pin Name	I/O	Format	Function and Operation
70	NC			Not used
71	VCC			VDD
72	VREF	I		A/D converter reference voltage input
73	AVSS			A/D GND
74	ADRMON	I		The remainder amount address monitor input
75	EREF			DRAM A/D reference voltage output
76	PH1	I		Disc photo sense input 1
77	PH2	I		Disc photo sense input 2
78	PH3	I		Disc photo sense input 3
79	ELVSNS	I		ELV position photo sense input
80	TEMP	I		Temperature detector input

*PD5575B

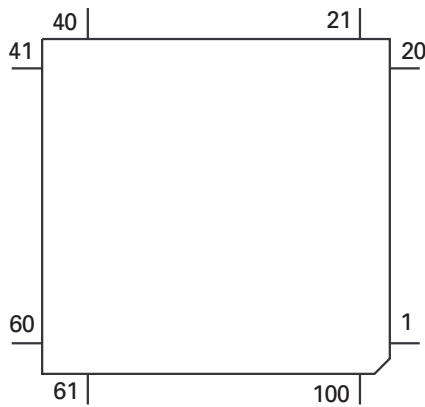

Format	Meaning
C	C MOS

*LC75804W

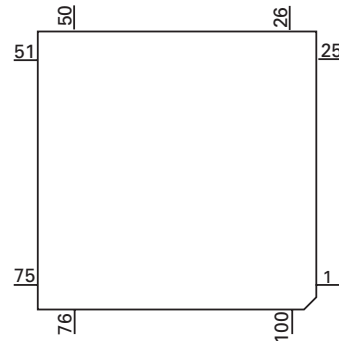

● Pin Functions (LC75804W)

Pin No.	Pin Name	I/O	Function and Operation
1-73	SEG01-73	O	LCD segment signal output
74-77	COM4-1	O	LCD common signal output
78,79	SEG75,76		Not used
80-83	KS3-6		Not used
84-88	KI1-5	I	Key scan input
89	VDD		Power supply
90	VLCD		Power supply for LCD driver
91	VLCD1	I	LCD drive bias impressed voltage (2/3) input
92	VLCD2	I	LCD drive bias impressed voltage (1/3) input
93	VSS		GND
94	TEST		GND
95	OSC	I/O	Oscillator terminal
96	RES	I	Reset signal input
97	DO		Not used
98	CE	I	Chip enable input
99	CL	I	Synchronizing clock input
100	DI	I	Transfer data input

7.3 EXPLANATION

7.3.1 SYSTEM BLOCK DIAGRAM

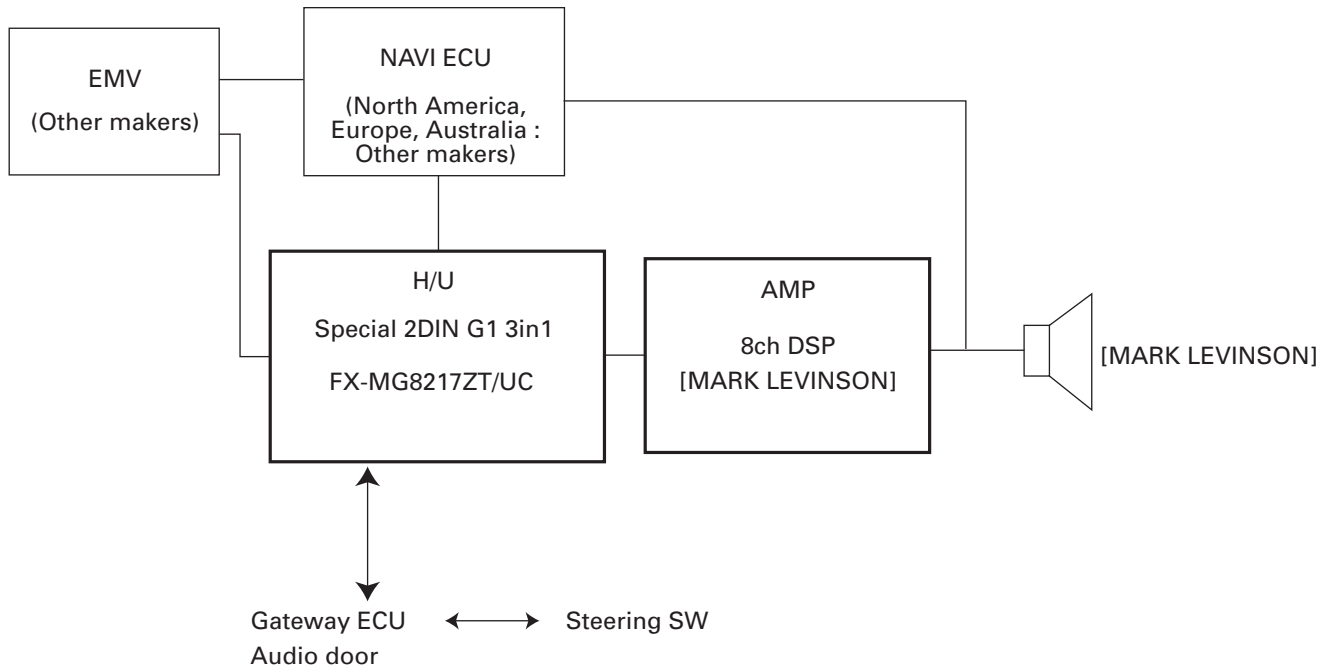

- EMV, NAVI, and TV TU depends on the model.
- MD changers are available for the European models.(Dealer options)
- Amplifier has the sound exchange function between left and right when received BUS information from the gateway.

Product combination

Destination	H/U	Amplifier
North America MARK LEVINSON	FX-MG8217ZT/UC	MARK LEVINSON

7.3.2 OPERATIONAL FLOW CHART

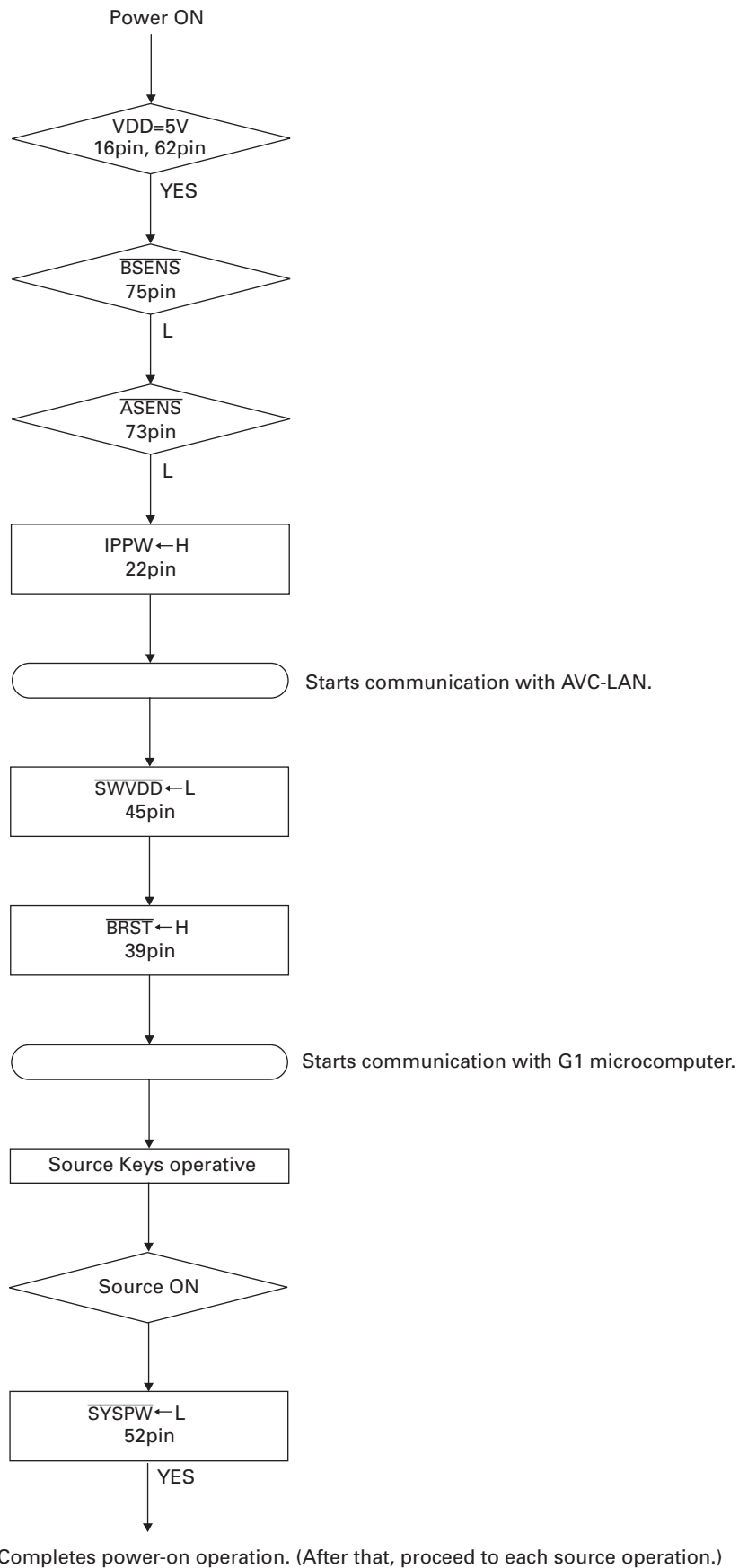

8. OPERATIONS AND SPECIFICATIONS

8.1 OPERATIONS

● RADIO

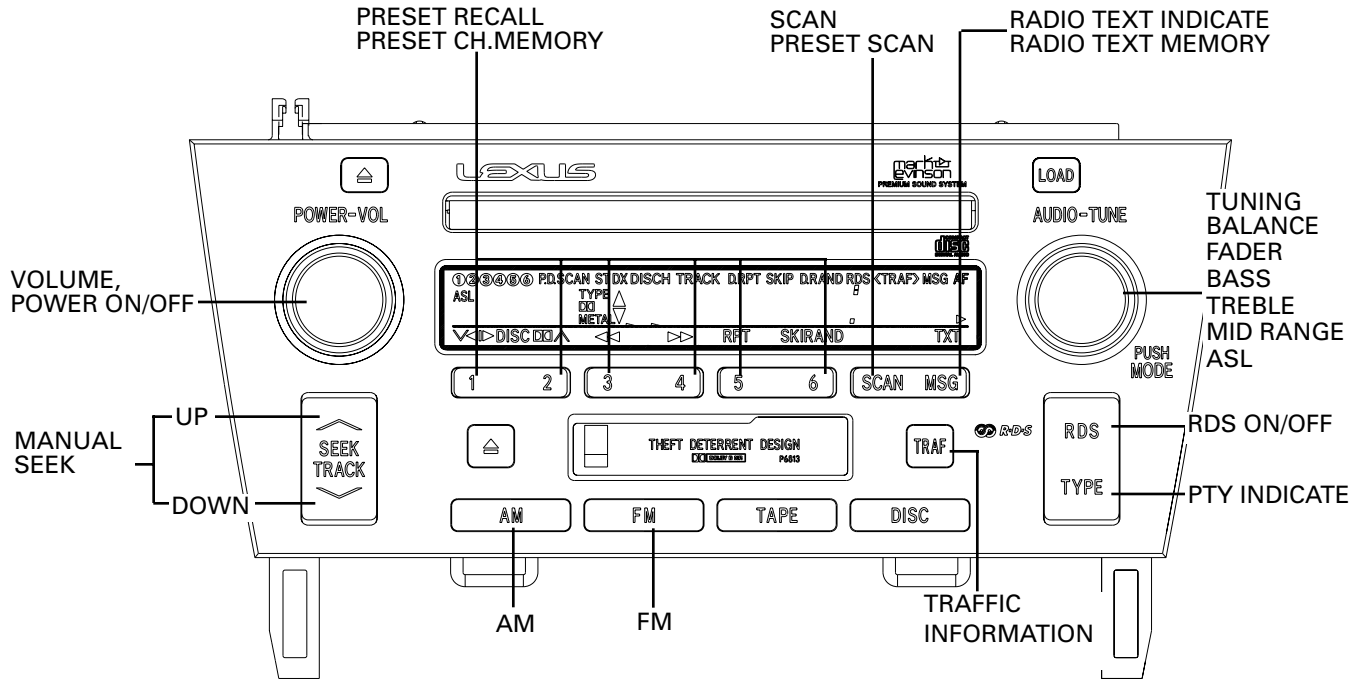

● TAPE

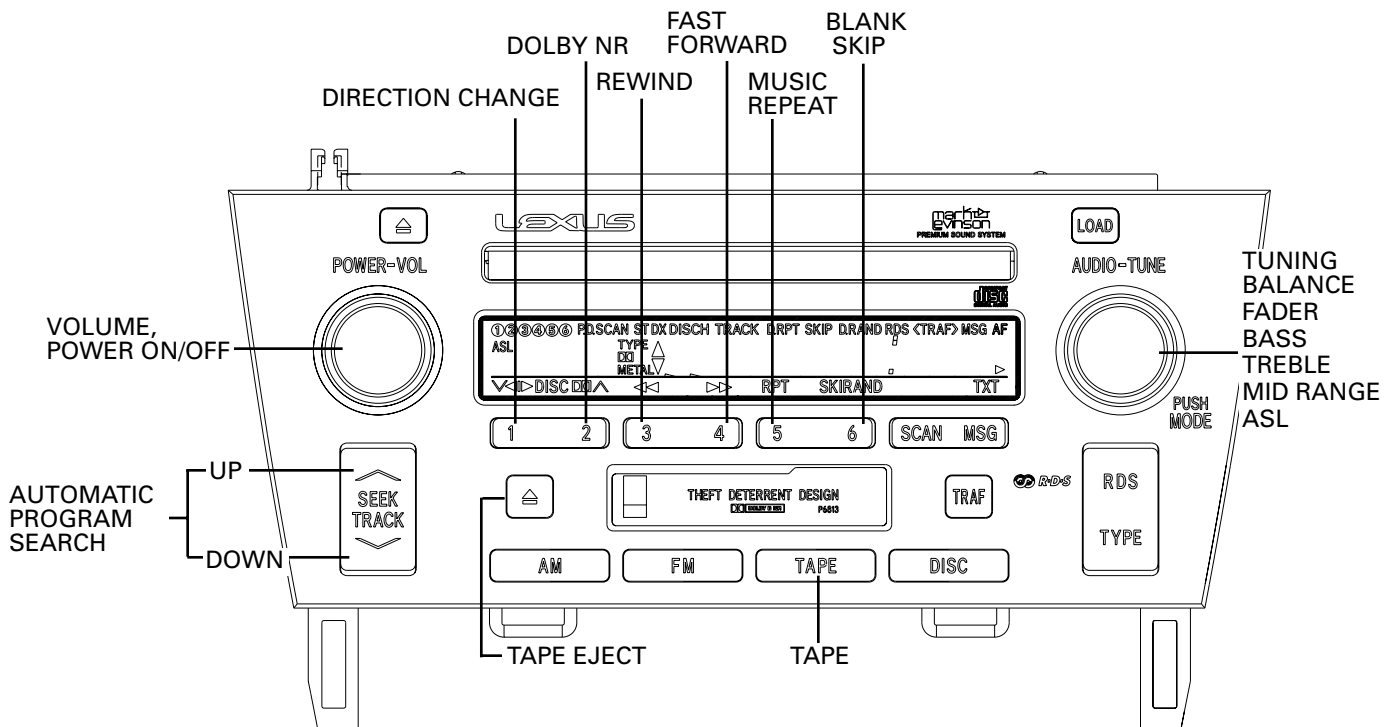

● CD

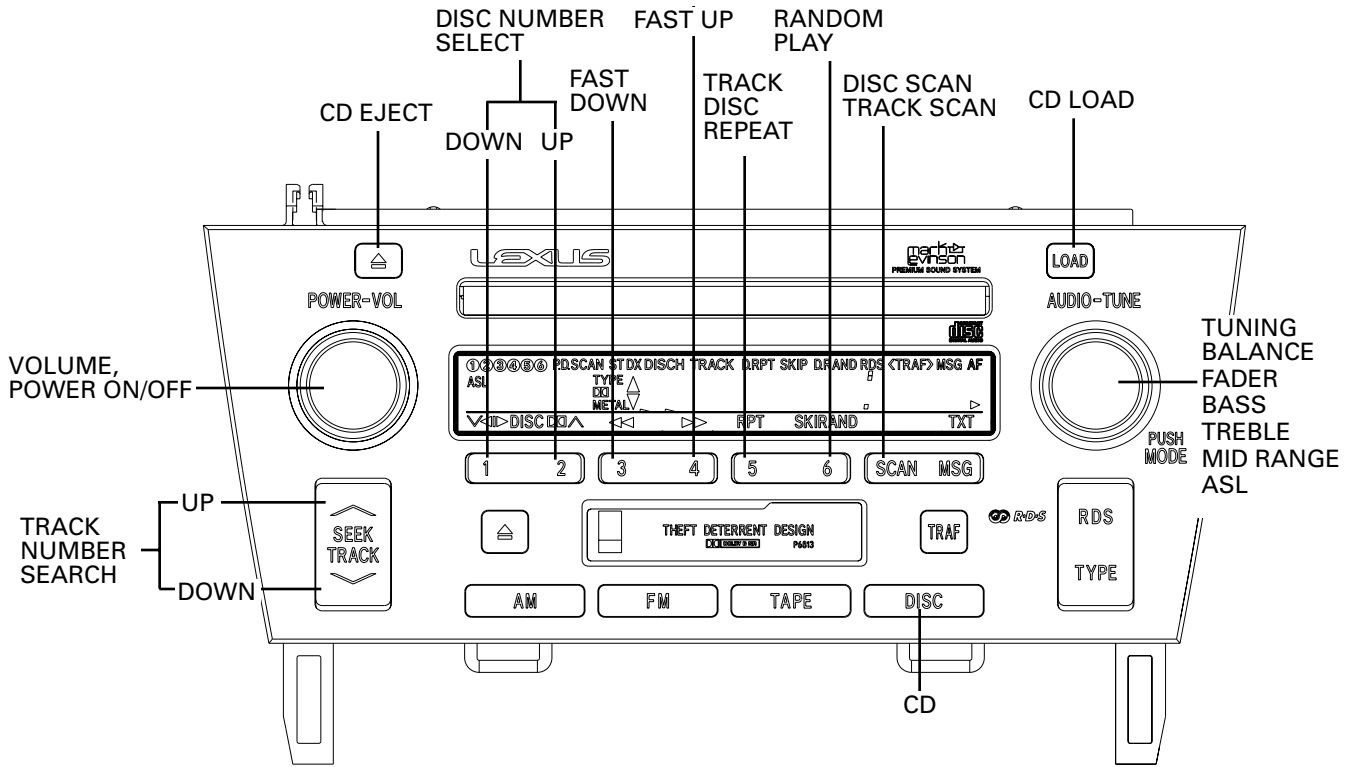

8.2 SPECIFICATIONS

Power source.....13.2V(10.5V-16.0V allowable) DC
 Backup current.....1.2mA or less
 Grounding system.....Negative type
 Dimensions(Chassis).....178(W)x100(H)x160(D)mm
 (Grille).....228(W)x100(H)x20(D)mm
 Weight.....2.6kg

Cassette player

Tape.....Compact cassette tape(C30-C90)
 Tape speed.....4.76 cm/sec.(+0.14 cm/sec.,-0.05 cm/sec.)
 Wow and flutter.....0.2% or less(WRMS)
 Crosstalk.....40dB or less
 Stereo Separation.....30dB or more
 S/N.....41dB or more
 Distortion.....3% or less

CD player

System.....Compact disc audio system
 Usable discs.....Compact disc
 Signal format.....Sampling frequency : 44.1kHz
Number of quantization : 16;linear

S/N.....70dB or more
 Distortion.....0.2% or less
 FM tuner
 Frequency.....87.75, 87.9-107.9 MHz
 S/N.....50dB or more
 Distortion.....1.5% or less
 IF interference.....89dB or more
 Image interference.....45dB or more
 Stereo Separation.....25dB or more(1kHz)

AM tuner

Frequency.....530-1710 kHz
 Selectivity.....50dB or more(±10kHz)
 S/N.....44dB or more
 Distortion.....1.0% or less
 IF interference.....60dB or more
 Image interference.....50dB or more

PIONEER CORPORATION 4-1, Meguro 1-Chome, Meguro-ku, Tokyo 153-8654, Japan
PIONEER ELECTRONICS SERVICE INC. P.O.Box 1760, Long Beach, CA 90801-1760 U.S.A.
PIONEER EUROPE NV Haven 1087 Keetberglaan 1, 9120 Melsele, Belgium
PIONEER ELECTRONICS ASIACENTRE PTE.LTD. 253 Alexandra Road, #04-01, Singapore 159936