



Technical Service Information Bulletin

October 20, 2000

Title: BRAKE PAD CLICKING NOISE

Models: '90 – '00 All Models

BRAKES
BR003-00

Introduction A clicking type noise may be noticed when first applying the brakes after changing vehicle travel direction (*Drive/Forward to Reverse, Reverse to Drive/Forward*). This is a normal noise caused by the required brake pad-to-caliper clearances. When the direction of travel is changed, the brake pads may "shift" towards the new direction of travel. When the brake pad contacts the caliper, a clicking noise may be heard.

To minimize this clicking noise, a disc brake caliper grease has been made available for use during brake service/maintenance operations. Under normal usage conditions this grease should be effective for a period of 6 months to 1 year.

- Applicable Vehicles**
- 1990 – 2000 model year Lexus vehicles, all models.

Parts Information

PREVIOUS PART NUMBER	CURRENT PART NUMBER	PART NAME
N/A	08887-80609	Disc Brake Caliper Grease (50 g tube)

Warranty Information

OP CODE	DESCRIPTION	TIME	OPN	T1	T2
N/A	Not Applicable to Warranty	-	-	-	-



Application Procedure There are two types of brake calipers: floating and fixed. Check the type of brake caliper installed on the vehicle by removing the wheel assembly.

1. Floating Type Brake Caliper

- A. Lift up or remove the brake caliper and suspend it securely.

HINT:
Do not disconnect the flexible hose from the brake caliper.

- B. If equipped with anti-squeal spring: Remove the anti-squeal springs.
- C. Remove the brake pads with anti-squeal shims.
- D. Remove the pad support plates from the torque plate. Clean any dust from the pad support plates, torque plates and brake pads.
- E. Apply a small amount of the disc brake caliper grease (1–2 mm thick) to both sides of the pad support plates.

NOTE:
Do NOT apply grease to the friction surfaces of the brake pads or the disc rotor.

- F. If the pad support plate is fixed to the torque plate with adhesive tape, perform the operation according to the following flow chart.

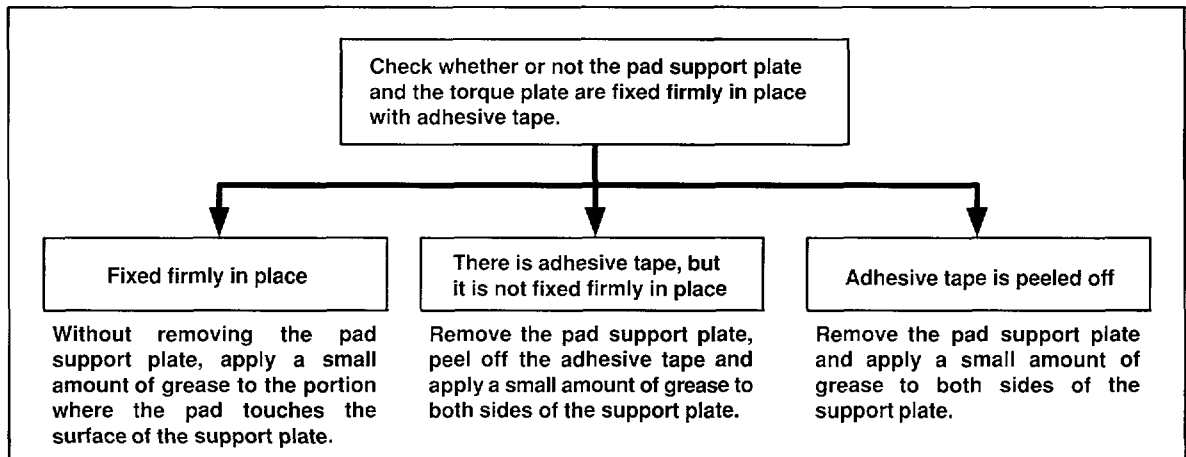
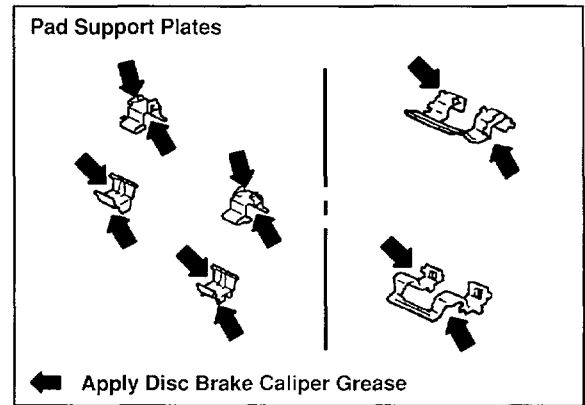
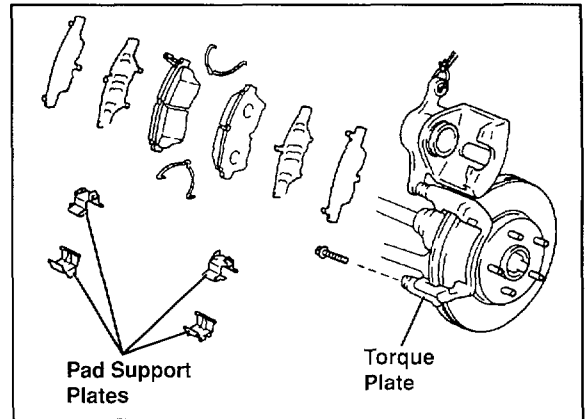

Application Procedure
(Continued)

- G. Apply a small amount of the disc brake caliper grease (1–2 mm thick) to the caliper as indicated in the illustration.
- H. Install the brake pads with the anti-squeal shims.
- I. If equipped with anti-squeal spring: Install the anti-squeal springs.
- J. Press the piston in firmly and install the brake caliper.

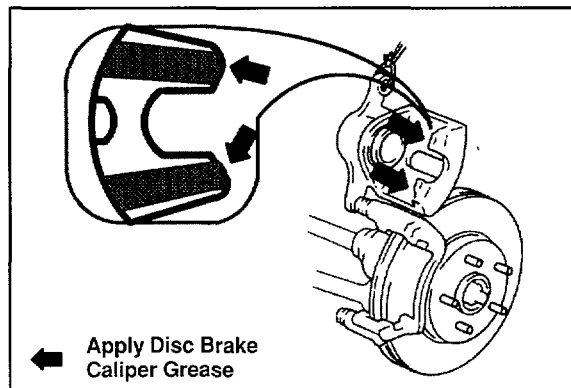

NOTE:

- Clean excess grease from brake pad and caliper.
- Do NOT apply grease to the friction surfaces of the brake pads or the disc rotor.

- K. Install the wheel assembly.

2. Fixed Type Brake Caliper

There are two types of brake pads:

- Type “A”: Has a projection on the upper and lower side of the brake pad. (See illustration.)
- Type “B”: Has a flat upper and lower edge on the brake pad backing plate.

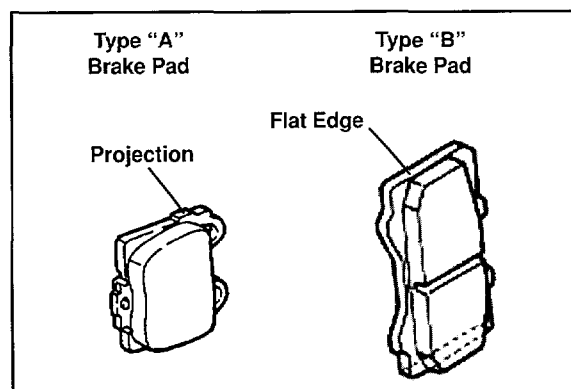

Type “A” Brake Pad

- A. Remove the anti-squeal spring, clip and pad guide pin.
- B. Remove the brake pads with the anti-squeal shims.
- C. Clean any dust from the brake pads.

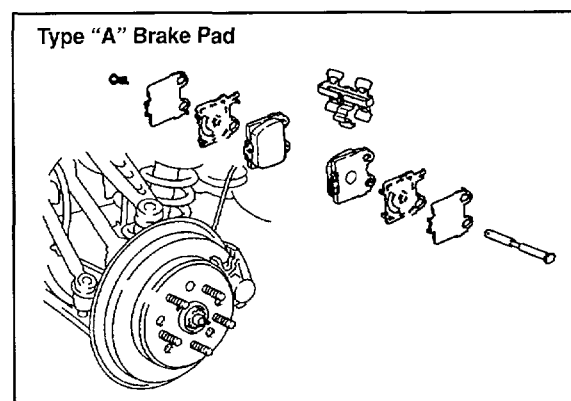

Application Procedure
(Continued)

- D. Apply a small amount of the disc brake caliper grease (1–2 mm thick) to the areas indicated in the illustration.

NOTE:

Do NOT apply grease to the friction surfaces of the brake pads or the disc rotor.

- E. Install the brake pads with the anti-squeal shims.

NOTE:

Clean excess grease from the brake pads and caliper.

- F. Install the pad guide pin, clip and anti-squeal spring.
- G. Install the wheel assembly.

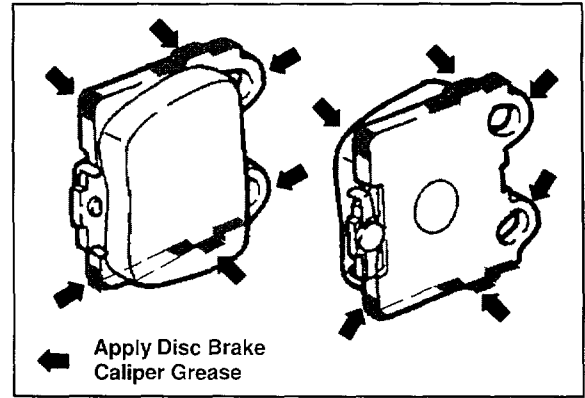

Type “B” Brake Pad

- A. Remove the clip, pins and anti-rattle spring/pad retainer clip.
- B. Remove the brake pads with the anti-squeal shims.
- C. Clean any dust from the brake pads.

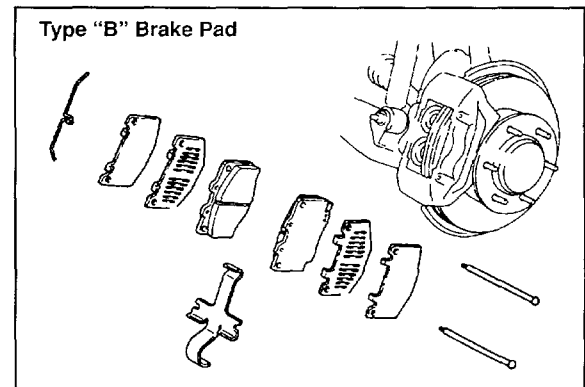

- D. Apply a small amount of the disc brake caliper grease (1–2 mm thick) to the areas indicated in the illustration.

NOTE:

Do NOT apply grease to the friction surfaces of the brake pads or the disc rotor.

- E. Install the brake pads with the anti-squeal shims.

NOTE:

Clean excess grease from the brake pads and caliper.

- F. Install the pad guide pin, clip and anti-squeal spring.
- G. Install the wheel assembly.

